

SHARP SERVICE MANUAL

No. S5409TQGX30/B

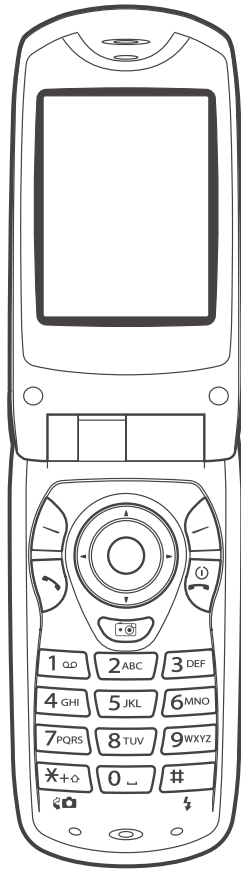

DIGITAL MOBILE PHONE MODEL **GX30**

(INTERNAL MODEL NAME:
TQ-GX30E/G/R/T/S/H/EP/PP/W/B/D/A/Z/Q/L/F/C/K/U)

- | | |
|--------------------------------|------------------------------------|
| E : For U.K. | G : For Germany |
| R : For Ireland | T : For Italy |
| S : For Spain | H : For Netherlands |
| EP : For U.K. (Prepaid) | PP : For Portugal (Prepaid) |
| W : For Sweden | B : For Hungary |
| D : For Greece | A : For Australia |
| Z : For New Zealand | Q : For Egypt |
| L : For Malta | F : For France |
| C : For Switzerland | K : For Austria |
| U : For Belgium | |

• In the interests of user-safety the set should be restored to its original condition and only parts identical to those specified should be used.

• Caution
Risk of explosion if battery is replaced by an incorrect type, dispose of used batteries according to the instruction.

CONTENTS

SERVICING CONCERNS

CHAPTER 1. GENERAL DESCRIPTION

- [1] Specifications 1-1
- [2] Names of parts 1-2
- [3] Operation manual 1-3

CHAPTER 2. ADJUSTMENTS, PERFORMANCE CHECK, AND FIRMWARE UPGRADE

- [1] SHARP Program Support Tool (SPST) 2-1
- [2] Test points 2-44
- [3] Troubleshooting 2-48

CHAPTER 3. DISASSEMBLY AND REASSEMBLY

- [1] Servicing Concerns 3-1
- [2] Disassembly and reassembly 3-4

CHAPTER 4. DIAGRAMS

- [1] Block diagram 4-1

CHAPTER 5. SCHEMATIC DIAGRAM AND WIRING SIDE OF P.W.BOARD

- [1] Notes on schematic diagram 5-1
- [2] Types of transistor and LED 5-1
- [3] Waveforms of circuit 5-2
- [4] Schematic diagram/
Wiring side of P.W.Board 5-5

CHAPTER 6. OTHERS

- [1] Function table of IC 6-1
- [2] Function table of Camera 6-27
- [3] Function table of Display 6-28

Parts Guide

Parts marked with "▲" are important for maintaining the safety of the set. Be sure to replace these parts with specified ones for maintaining the safety and performance of the set.

SERVICING CONCERNS

1. When requested, back-up user's handset data using SPST (SHARP Program Support Tool). Otherwise, before servicing, warn the user that data in the memory may be lost during repairs.
2. Upgrade the firmware to the latest version using SPST before returning the handset to the customer.
3. After repairs, inspect the handset according to the following flowchart.

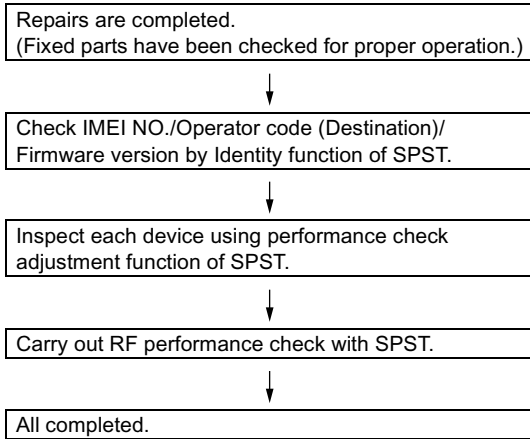

4. When storing or transporting a PWB, put it into a conductive bag or wrap it in aluminum foil. (C-MOS IC may be damaged by electrostatic charges.)
5. Do not leave fingerprints, etc. on ornamental parts including a cabinet, especially clear windows for main and sub displays. Wear fingerstalls to avoid this.
Also, ensure not to leave fingerprints on the surface of main and external display panels.
6. To prevent oxidation which causes connection problems, do not touch any terminals on the electric board, microphone, vibrator, earpiece and speaker.
When handling these parts, wear fingerstalls. Should you touch these parts, clean them with a soft dry cloth.
Always wear fingerstalls when handling a shield case on the electric board. Otherwise oxidation may occur causing handset performance deterioration.
7. The FPC is a precision device. Handle it carefully to prevent any damages.
8. Do not expose the moisture sensor to liquids.
If the sheet gets wet, red ink runs. In this case, replace the sheet with a new one.
Be careful about your perspiration.
9. Before you disassemble or reassemble handset, make sure to remove the Li-Ion battery.
10. Be sufficiently careful with static electricity of integrated circuits and other circuits. Wear static electricity prevention bands while servicing.

CHAPTER 1. GENERAL DESCRIPTION

FOR A COMPLETE DESCRIPTION OF THE OPERATION OF THIS UNIT, PLEASE REFER TO THE OPERATION MANUAL.

[1] Specifications

General: Quad - band (GSM 850 MHz/GSM 900 MHz/
DCS 1800 MHz/PCS 1900MHz)
GPRS-enabled
WAP, MMS, SMS

Dimensions (folded, excluding the aerial)
(H x W x D): 95 x 49 x 26 mm
Weight: 110 g

Battery operating temperature: 0°C - 40°C

Main display: Display dimensions: 240 x 320 pixels
LCD display: CGS 262,144 colours with back-light
LCD back light: LED back light white colour LEDs

External display: Display dimensions: 64 x 96 pixels
LCD display: STN 65,536 colours LCD with back light

Camera: CCD 1M pixels built-in camera
Zoom: Wide and zoom mode
[Supported 20 (when image size is 160 x 120 pixels) x zoom]
Lens: F2.8, f = 3.7 mm

Sound: 40-polyphonic ring melodies

Mobile light: 7 colours

External DC supply voltage: 5.2 V

Battery: 3.7 V, 780 mAh, Li-Ion

Standby time: 100 ~ 250 hours

Talk time: 160 ~ 240 min.

Others: Side key
Infrared port 1.2 L/P (maximum distance 20 cm)
Connector for AC charger and data cable
Standard hands free connector (ø2.5)

Battery running time depends on the battery and SIM card as well as the network conditions and usage

Specifications for this model are subject to change without prior notice.

Powered by JBlend™ Copyright 1997-2003 Aplix Corporation. All rights reserved. JBlend and all JBlend-based trademarks and logos are trademarks or registered trademarks of Aplix Corporation in Japan and other countries.



Powered by Mascot Capsule®/Micro3D Edition™
Mascot Capsule® is a registered trademark of HI Corporation
©2002-2003 HI Corporation. All Rights Reserved.

Licensed by Inter Digital Technology Corporation under one or more of the following United States Patents and/or their domestic or foreign counterparts and other patents pending, including U.S. Patents: 4,675,863; 4,779,262; 4,785,450 & 4,811,420.

Licensed under U.S. Patent 4,558,302 and foreign counterparts.

T9 Text Input is licensed under one or more of the following: U.S. Pat. Nos. 5,818,437, 5,953,541, 5,187,480, 5,945,928, and 6,011,554; Australian Pat. No. 727539; Canadian Pat. No. 1,331,057; United Kingdom Pat. No. 2238414B; Hong Kong Standard Pat. No. HK0940329; Republic of Singapore Pat. No. 51383; Euro. Pat. No. 0 842 463 (96927260.8) DE/DK, FI, FR, IT, NL,PT,ES,SE,GB; Republic of Korea Pat. Nos. KR201211B1 and KR226206B1; and additional patents are pending worldwide.

SD logo  is a trademark.

Bluetooth is a trademark of the Bluetooth SIG, Inc.



The Bluetooth word mark and logos are owned by the Bluetooth SIG, Inc. and any use of such marks by Sharp is under license. Other trademarks and trade names are those of their respective owners.

CP8 PATENT

[2] Names of parts

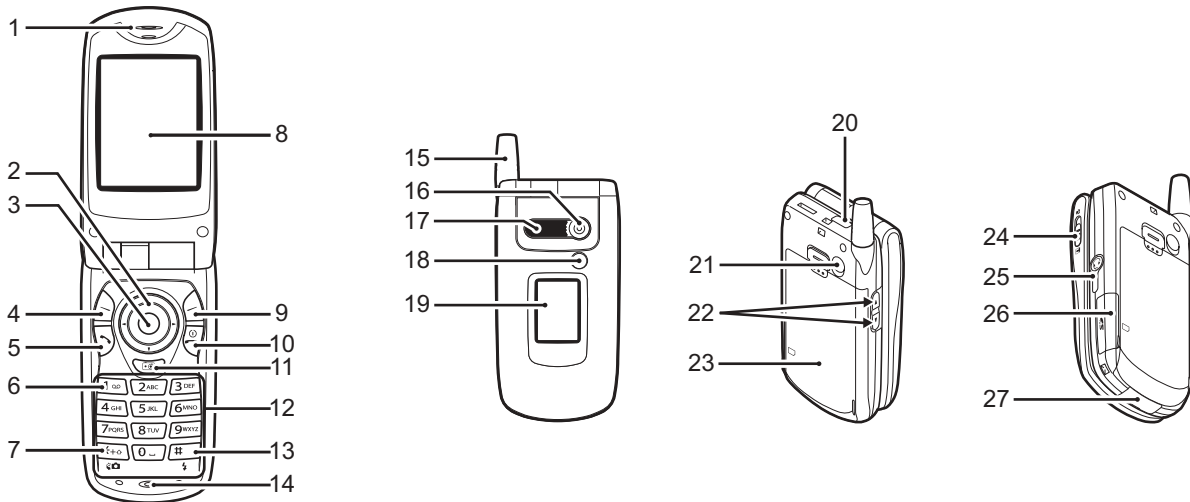

- 1. Earpiece**
- 2. Navigation Keys (Arrow Keys):**
 Moves cursor to select menu items, etc.
 ▲, ▼, ◀, ▶ in this manual indicate these keys.
 Up/Down arrow keys: Displays Contacts List entries in stand-by mode.
 Left arrow key: Displays list of Applications in stand-by mode.
 Right arrow key: Displays Pictures screen in stand-by mode.
- 3. Centre Key:**
 Displays Main menu in stand-by mode and executes functions.
 ● in this manual indicates this key.
- 4. Left Soft Key:**
 Executes the function at the bottom left of the screen.
 ▽ in this manual indicates this key.
- 5. Send Key:**
 Makes or accepts calls, views the call in stand-by mode.
- 6. Voice Mail Key:**
 Press and hold this key to connect to the Voice mail centre automatically.
 (Depends on the SIM card.)
- 7. */Shift Key, Viewfinder Switch Key:**
 Switches character case among four modes: Abc, ABC, 123 and abc.
 Switches viewfinders between main display and external display in digital camera/video camera mode.
- 8. Main Display**
- 9. Right Soft Key:**
 Executes the function at the bottom right of the screen.
 ▽ in this manual indicates this key.
 Used to access "Vodafone live!" by opening the browser in stand-by mode.
- 10. End/Power Key:**
 Ends a call, turns power on/off.
- 11. Camera Key:**
 Starts the digital camera in stand-by mode.
- 12. Keypad**
- 13. #/Flash light Key:**
 Switches symbol screens.
 Press and hold this key to shift text input method between multi-tap and T9 mode.
 Turns the flash/auxiliary light on or off in digital camera/video camera mode.
- 14. Microphone**
- 15. Aerial**
- 16. Camera**
- 17. Speaker**
- 18. Mobile Light:**
 Used as a flash or an auxiliary light in digital camera/video camera mode, as a battery charge indicator, or notification for incoming calls, data/fax calls or messages.
- 19. External Display**
- 20. Infrared Port:**
 Sends and receives data via infrared.
- 21. RF Connector**
- 22. Side-Up/Side-Down Keys:**
 Moves cursor to select menu items, adjusts earpiece volume, etc.
 In stand-by mode, press and hold this key to turn the mobile light on and off. When the mobile light is on, press this key to change the light colour.
- 23. Battery Cover**
- 24. Macro Switch (Close-up):**
 Switches between normal (👤) and macro (🌸) position.
- 25. Handsfree Kit Connector**
- 26. Memory Card Slot Cover**
- 27. External Connector:**
 Used to connect either the charger or USB data cable.

[3] Operation manual

(Page numbers refer to the user guide)

[Optional Accessories]

- Spare Lithium-ion battery (XN-1BT30)
- High capacity Lithium-ion battery (XN-1BT31)
- Cigarette lighter charger (XN-1CL30)
- USB data cable (USB cable: XN-1DC30)
- AC charger (XN-1QC30, XN-1QC31, XN-1QC32)
- Personal handsfree kit (XN-1ER20)

The above accessories may not be available in all regions. For details, please contact your dealer.

[Quickstart Guide]

THE SHARP GX30 QUICK START GUIDE

In just a few minutes we'll show you how easy it is to use many of the new features of your Sharp GX30. You'll be able to take high-quality digital photos and video clips with its built-in zoom camera, and send them as MMS messages. You'll also find out how to connect to Vodafone live! and the mobile internet to download new polyphonic ringtones, games and background wallpapers!

Getting started

- 1. Insert your SIM card:**
Slide off the back cover, and remove the battery. Slide your Vodafone SIM card (with the gold contacts facing downwards) into its holder, making sure that the cut-out corner is aligned. Replace the battery and cover.
- 2. Insert the SD memory card:**
Open the side SD slot and slide the memory card in.
- 3. Turn it on:**
Make sure the battery is charged (see the User Manual for details). Open the handset, then press and hold the red key. (You do the same to turn it off again.)

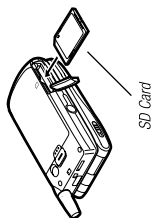
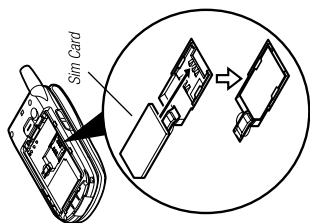

1. USING THE HANDSET

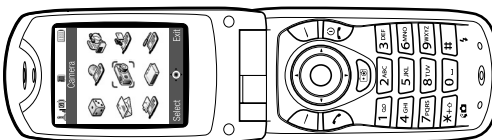

[In Standby mode.]

Keys & navigation

- Centre key:** Selects an item or confirms an action.
[In Standby mode] Takes you to the main Menu (shown in picture).
[In Camera mode] Captures a picture.
- Navigation:** Use the edge of the centre key to move around icons and item lists.
[In Standby mode] for Contacts, for Pictures and for Applications.
- Soft keys:** Select the icon or command shown in the bottom left or right of the screen.
The key selects icons in the middle.
[In Standby mode] goes to Messages, connects to Vodafone live!
- Call key:** [When ringing] Answers a call.
[In Standby mode] Goes to Dialed numbers, then for Missed calls, Received calls.
- End key:** [During a call] Ends a call.
[Press and hold] Turns handset on and off.
[In menus] Takes you back to idle mode.
- Camera key:** [In Standby mode] Turns on the camera.

2. THE CAMERA

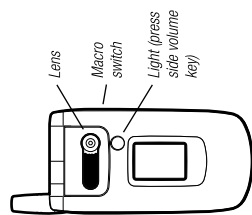

The GX30's camera with built-in zoom allows you to take digital photos and video clips. These can then be saved and sent via MMS to another mobile device or sent to a separate email address.

Take a photo or video clip

- 1. Take a photo:**
Press the Camera key in Standby mode to turn on the camera. Press to take the photo. **Tips:** use for brightness, and for zoom. To change photo size or quality, press [Options]. For close-up shots, use the Macro switch.
- 2. Save your photo:**
Press [Cancel] to try again, or press [Save] to save it, (in **Menu/My Stuff/Pictures/Memory Card**). Or press [MMS] to save and send it as **Multimedia** (MMS message – see next page). High-quality photos will be automatically compressed for sending.
- 3. Take a video clip:**
Press in Standby mode to go to the main Menu. Press again to select **Camera**, then select **Record Video**. Press [MMS] to start, and again to stop. Choose **Save**, **Preview** or **Save and Send** (in an MMS message).



4. Add a new page:

To send more than one picture or sound, choose [Options]/**Add Slide**.

5. Preview your message:

Press [Options], and select **Preview Message**. Then select [Options]/**Done**.

Send your MMS

1. Add a Contact:

Choose [Options]/**Add Contact**. Enter a mobile number (if the receiving phone can't display MMS messages, they'll be sent a link to a web page they can view them on). Press, then choose **Send**. **Tip:** Try sending it to yourself, to see how it works!

2. Other Send options:

To send your MMS to an email address, choose **Add Contact/Options/Input E-mail address**. Enter the email address (press three times for the @ symbol). Or choose **Contacts list** from the options menu to use details from your Contacts list. Then press and choose **Send**.



3. MMS (Picture Messaging)

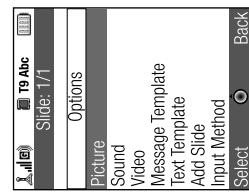

Predictive text (T9)

To turn T9 off and on while entering text, press and hold the key. Use to cycle through the alternative words, then to select the one you want.



Life is more than just text – with MMS you can now send pictures, sounds and video clips as well!

Create a new MMS

- 1. Write your message:**
Select **Messages** in the main Menu (or press the key in Standby mode). Select **Create Message**, then **Multimedia**. Now use the keypad to write your text. **Tips:** to enter punctuation or other characters, press the key and select the symbol you want. For a space, press. Press the key to cycle through capitals, numeric, etc. (shown at the top of the screen).
- 2. Add a photo or video clip:**
Press [Options] and select **Picture** or **Video**. Choose **Memory Card**, and select the photo or video clip you want. Press to attach it, then press again to return to the Create screen. (**Note:** If you're sending a video clip you may not be able to attach anything else.)
- 3. Add a sound file:**
Select [Options]/**Sound**. Follow the same procedure as adding a picture. **Tip:** If no sounds are available, you can go to **Menu/Applications/Voice Recorder** and record a new one.

4. VODAFONE live!



Browsing

Use the navigation keys to highlight the item you want to select, then press: to open that page. Press [Back] to go back a page. Press [Options] for the Browser Option menu.

Vodafone live! is a mobile internet portal which is a new world of information, downloads, games, music and services. Your GPRS connection can be 'always on' - which means no waiting for a dial-up connection. You only pay for data you send or get, not how long you're connected.

Connect to vodafone live!

Simply press the key (in Standby mode) to connect you to the Vodafone live! main menu. To exit, press the key. Or link directly to Vodafone live! services:

In the main Menu, select the **Vodafone live!** section, and choose your service:

- Games:** Online fun and games to download...
- Ringtones:** Download music, sounds and ringtones.
- Pictures:** Download images, animations and background wallpaper.
- News:** Get the latest news reports and weather forecasts...
- Sport:** News, results and latest scores (with pictures).
- Find & Seek:** Get the local information you need, wherever you are.
- Chat:** Chat with others on PCs, PDAs and mobiles.
- Search:** Find what you need in Vodafone live!

Tip: Vodafone live! is growing and changing all the time, so these options may vary. Keep checking it out to see what's new.



5. DOWNLOADS

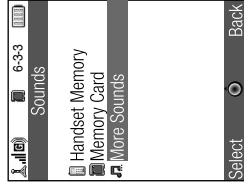

Personalise your new handset by downloading new ringtones, images and background wallpaper from Vodafone live!. You can download from the Vodafone live! portal or the handset shortcuts (see previous page), or use the **More** menus:

Download more

1. Download a new ringtone, video clip or background wallpaper:

Go main **Menu/My Stuff**, choose **Sounds, Videos or Pictures** and then **More Sounds, More Videos** or **More Pictures**. Choose a ringtone, video clip or wallpaper image and follow the instructions to download it.

To activate your ringtone, go to **Profiles** (in the main Menu), select **Normal**, then choose (Options)/**Personalise/Assign Ringtone/My Sounds**, then select your downloaded ringtone. To set your wallpaper, go to **My Stuff/Pictures**, select your downloaded image and choose (Options)/**Set as wallpaper**.

2. Download new games:

To add more arcade quality games to your handset, go to **Menu/Games & More/More Games**. Choose a game to download, and you'll find it in **Games & More/Applications**.

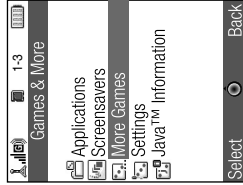

6. OTHER FEATURES

Handset hints

1. Silent mode:

To go into Silent mode (if you're in a meeting, say), press and hold the **[Mute]** key (in Standby mode) and select the **Silent** profile. Select **Normal** to restore your ring volume.

2. External light:

Press and hold the external Volume key up or down to switch the light on or off, and press again to change the colour. This works in both open and closed handset modes.

3. MP3 player:

Transfer MP3 files onto your SD card. Go to **Menu/Applications/MP3 Player/Memory Card**, and choose the files you wish to play. (See the User Guide for more details.)

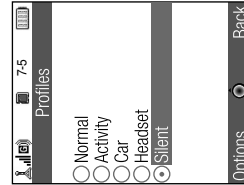

CHAPTER 2. ADJUSTMENTS, PERFORMANCE CHECK, AND FIRMWARE UPGRADE

SPST (SHARP Program Support Tool) allows you to adjust settings, conduct performance checks, and upgrade the firmware.

[1] SHARP Program Support Tool (SPST)

1. System requirements

- IBM PC compatible personal computer (standard COM1 115,200 bps serial port and USB required)
Supported OS: Windows 98/98SE/2000/XP (except for Windows 95/ME/NT)
(English, German, Italian, Spanish, French and Chinese versions)
- Data cable

<During RF adjustment>

- GSM tester: CMU200
- GPIB interface: National Instruments USB-GPIB cable (Model No.: NI GPIB-USB-B)

2. Introduction

2.1. Functions

SPST offers seven key functions:

- 1) Firmware download
- 2) User data transfer (processes all data at once but not individually.)
- 3) RF calibration check and test
- 4) Default setting
- 5) Identification
- 6) Performance check and adjustment
- 7) User password reset

2.2. Installation

1. Use Windows Explorer to execute the "setup.exe" file on the CD-ROM.
2. The SPST GX30 setup wizard appears. Follow the installation instructions.
3. After the installation is complete, shortcuts to SPST are created on the desktop and under the "Start" — "Programs" — "GX30" menu. Start SPST from the shortcuts.

2.3. Starting up

Connect GX30 to an operable serial port of the PC with the supplied data cable. Make sure that the battery is fully charged. Start SPST from the desktop.

1. The Input password dialog box appears. Enter the password, select a port where GX30 is connected from the list box, and click "OK". If you do not know SPC, click "Cancel" to exit.

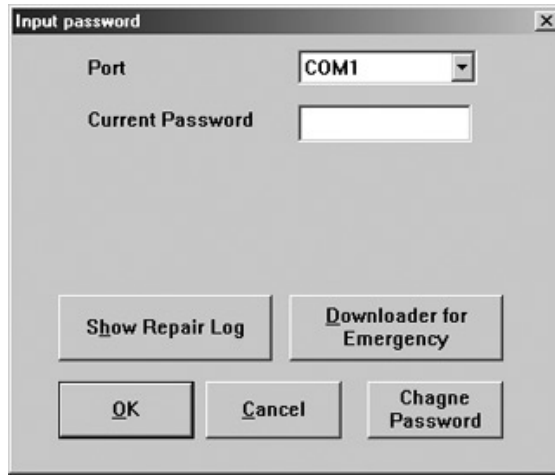

Figure 1

2. To change the password, enter the current password in figure 1, and then click "Change Password".

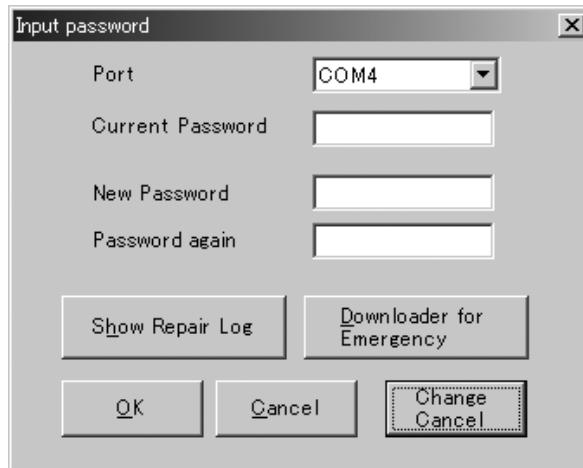

Figure 2

3. To check the usage status of tools, click "Show Repair Log" in figure 1.
4. Click "Downloader for Emergency".

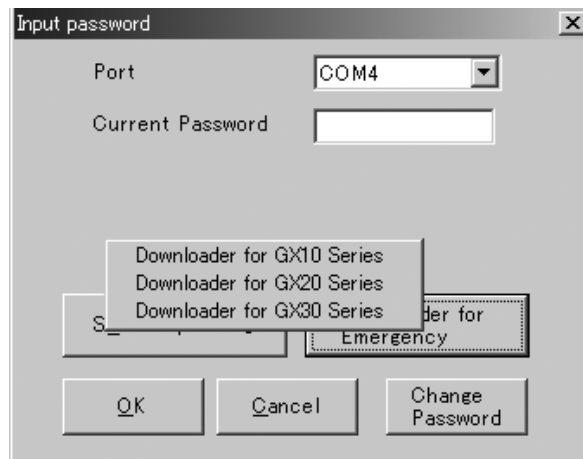

Figure 3

The above screen appears. Select a model to use and execute the Downloader. (Use this to initialize the flash, etc.)

5. When the password is correct, a connection is established and the following screen appears.

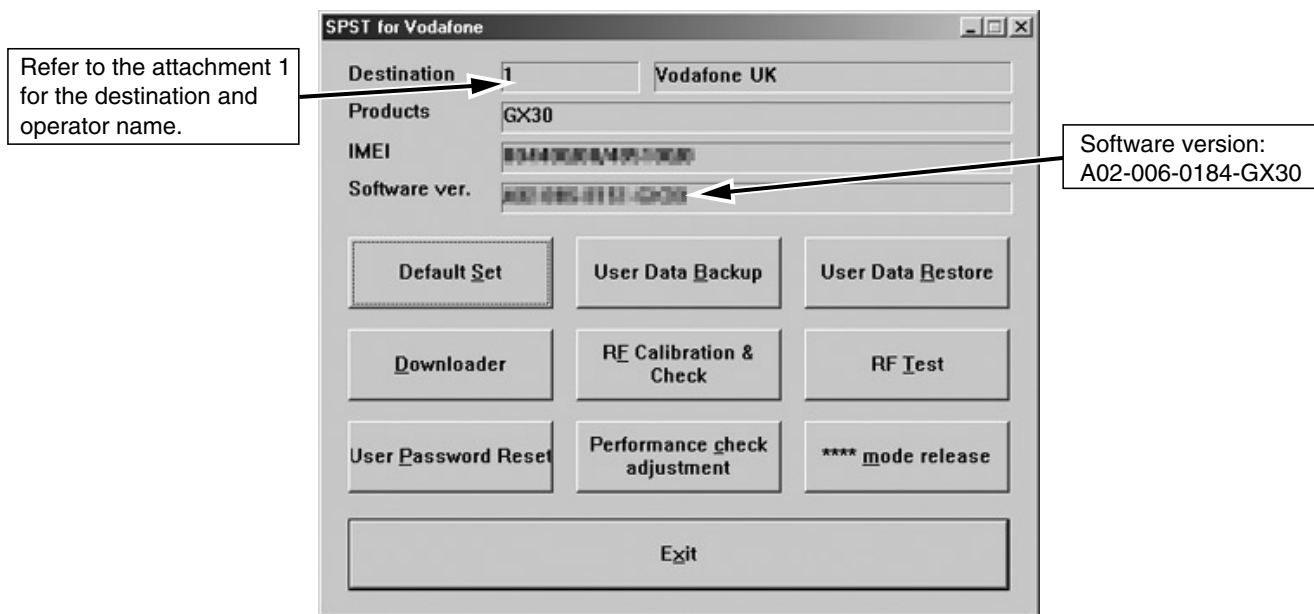

Figure 4

Buttons

Default Set	Refer to "4.1. Default setting". (see page 2-5)
User Data Back-up	Refer to "4.2. User data back-up". (see page 2-6)
User Data Restore	Refer to "4.3. User data restore". (see page 2-7)
Downloader	Refer to "4.4. Downloader". (see page 2-8)
RF Calibration & Check	Refer to "4.5. RF calibration & check". (see page 2-19)
RF Test	Refer to "4.6. RF test tool". (see page 2-28)
User Password Reset	Refer to "4.7. Password reset". (see page 2-34)
Performance check adjustment	Refer to "4.8. Performance check and adjustment". (see page 2-35)
**** mode release	Refer to "4.9. ****mode release". (see page 2-42)
Exit	End SPST.

Attachment 1 Destination and Operator name Chart

No.	Operator name		Country	Model name
01	Vodafone UK	Post-Paid	UK	A4TQGX30E
02	Airtel	Post-Paid	Spain	A4TQGX30S
03	SFR	Post-Paid	France	A4TQGX30F
04	Vodafone Omnitel	Post-Paid	Italy	A4TQGX30T
05	D2	Post-Paid	Germany	A4TQGX30G
06	Vodafone NL	Post-Paid	Netherlands (Holland)	A4TQGX30H
08	Vodafone Ireland	Post-Paid	Ireland	A4TQGX30R
10	Vodafone Greece	Post-Paid	Greece	A4TQGX30D
11	Vodafone Hungary	Post-Paid	Hungary	A4TQGX30B
12	Vodafone Australia	Post-Paid	Australia	A4TQGX30A
13	Vodafone New Zealand	Post-Paid	New Zealand	A4TQGX30Z
14	Vodafone Sweden	Post-Paid	Sweden	A4TQGX30W
15	Vodafone Egypt	Post-Paid	Egypt	A4TQGX30Q
16	Vodafone Malta	Post-Paid	Malta	A4TQGX30L
17	Swisscom	Post-Paid	Switzerland	A4TQGX30C
18	mobilkom austria	Post-Paid	Austria	A4TQGX30K
19	Belgacom mobile	Post-Paid	Belgium	A4TQGX30U
48	Vodafone PT	Pre-Paid	Portugal	A4TQGX30PP
50	Vodafone UK	Pre-Paid	UK	A4TQGX30EP

3. Adjustments for GX30

1. Adjustments are required after replacing the following parts. (○)

Parts	Temperature adjustment (Camera)	Temperature adjustment (Battery)	Main display flicker adjustment	External display contrast adjustment	White defect correction	Black defect correction
TH101	×	○	×	×	×	×
TH701	○	×	×	×	×	×
Main display unit	×	×	○	×	×	×
External display unit	×	×	×	○	×	×
Camera unit	×	×	×	×	○	○

When replacing other parts in the RF section, carry out RF calibration.

2. Click the buttons on the SPST screen for adjustments.

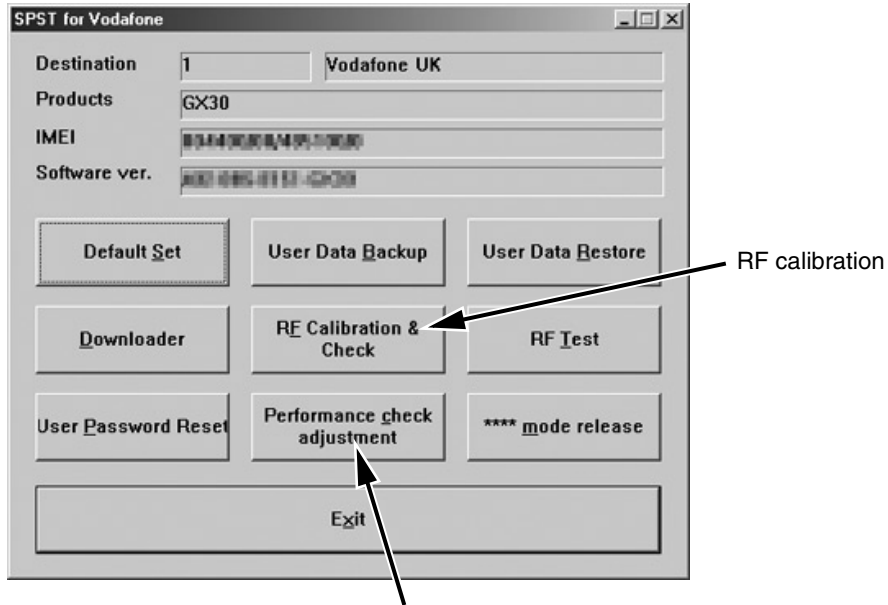

To adjust the device, click this button (Performance check adjustment).

Figure 5

3. The following screen appears.

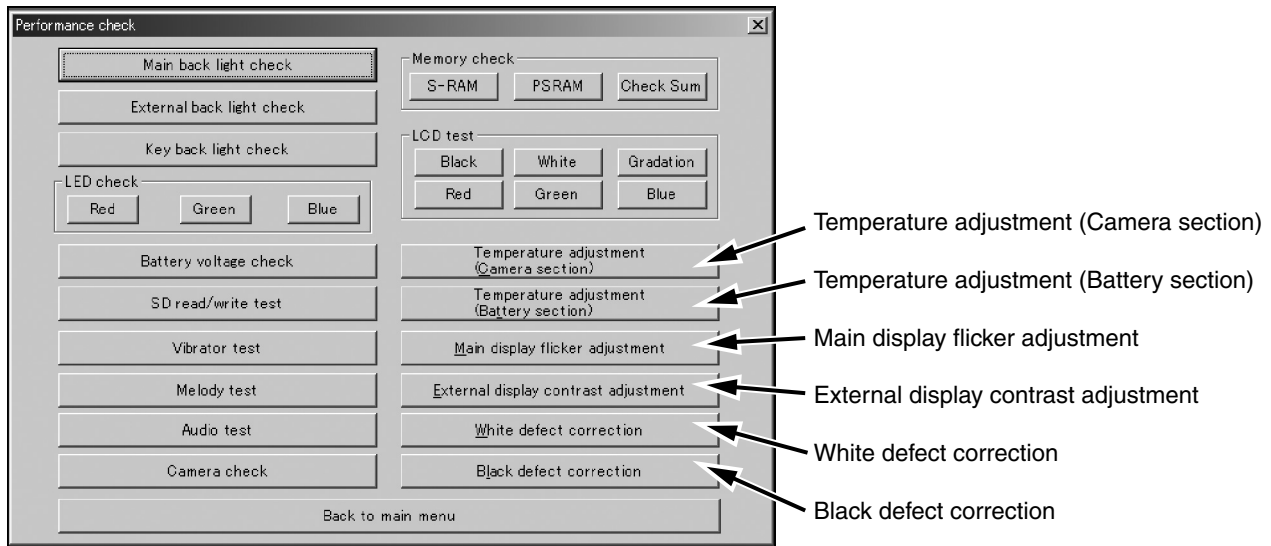

Figure 6

4. Functions

4.1. Default setting

SPST can restore the factory settings.

This function

1. Deletes all user data in the file system;
2. Restores all WAP settings to default; and
3. Restores the values set by the user to default;

(MEP_LOCK settings and the destination and operator name do not change.)

<Operation>

- 1) Set the COM port on the SPST initial screen and click "Default Set".
- 2) Click "Yes" to proceed. Click "No" to exit.

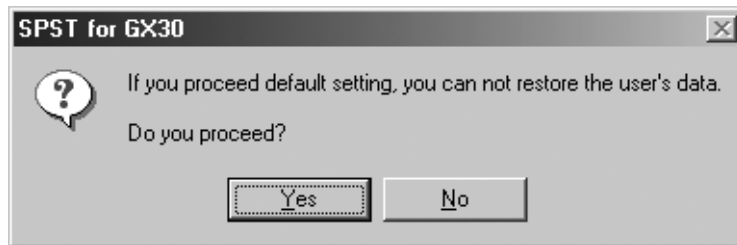

Figure 7

- 3) Click "Yes" to back-up the MEPLOCK data. Click "No" to restore default settings.

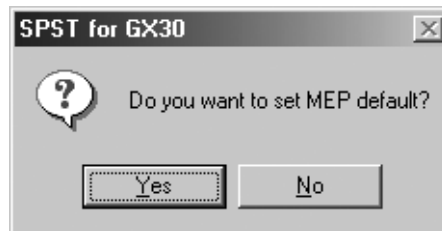

Figure 8

- 4) Communication starts.



Figure 9

- 5) The following appears when you select "Yes" in step 3 and MEPLOCK data exists. Click "Yes" to restore the data.

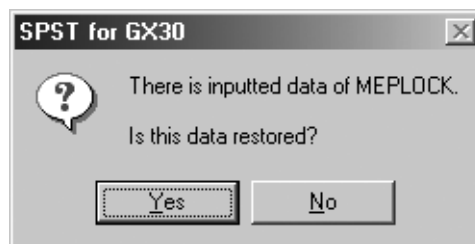

Figure 10

6) After the handset is turned on, the initialization is complete.



Figure 11

4.2. User data back-up

SPST saves all the data stored on the handset.

1. Set the COM port on the SPST initial screen and click "User Data Back-up".
2. Specify the file name in the following dialog box and click "Save".

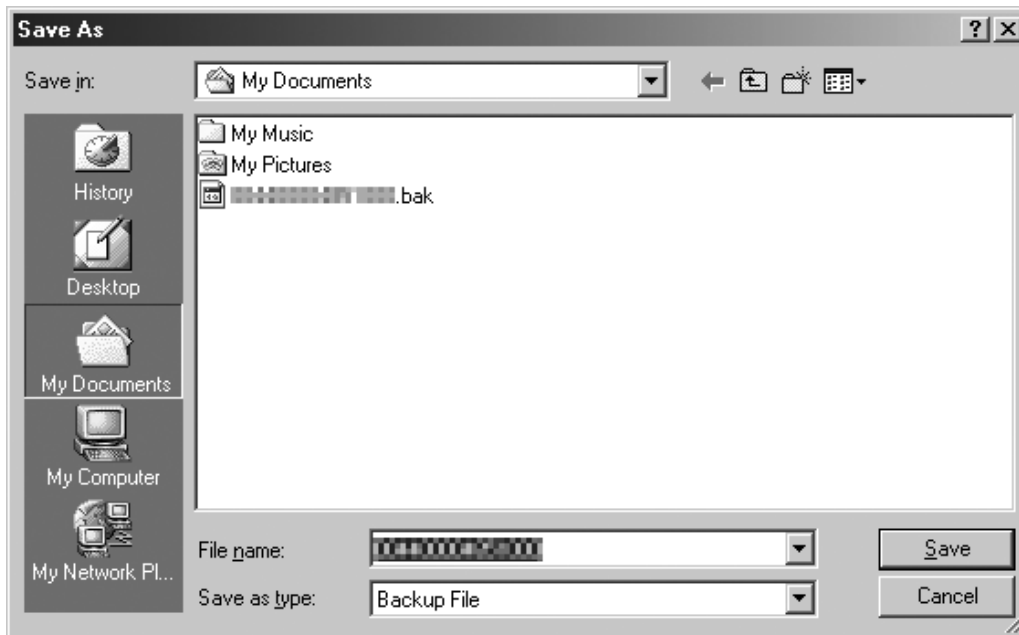

Figure 12

3. The communicating dialog box appears while processing.

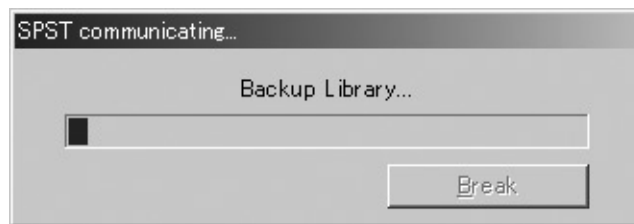

Figure 13

4. When completed, the following message appears. Click "OK".



Figure 14

4.3. User data restore

SPST completely restores the backed up data.

1. Set the COM port on the SPST initial screen and click "User Data Restore".
2. Specify the file name in the following dialog box and click "Save".

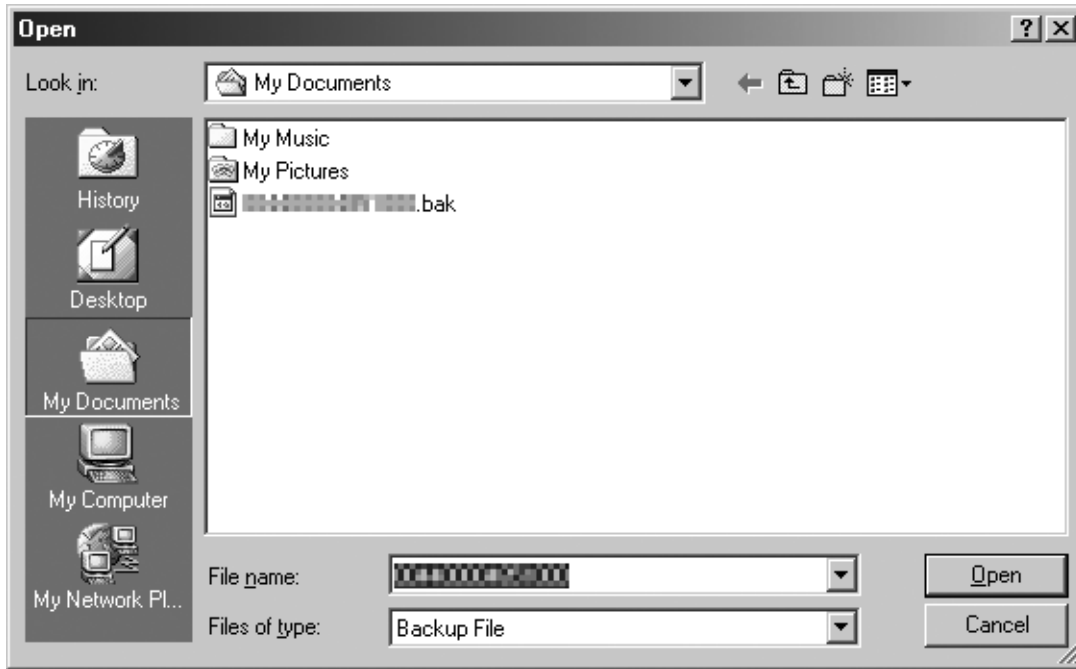

Figure 15

3. The communicating dialog box appears while processing.

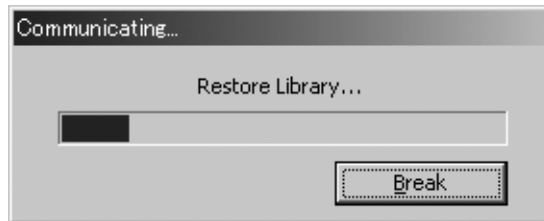

Figure 16

4. When the restore is complete, click "OK".



Figure 17

4.4. Downloader**4.4.1 Introduction**

Downloader allows you to upgrade the firmware.

1) Required devices

The following devices are required to rewrite MOT files using Communication Box.

Conversion connector (16-pin → 10-pin)

This conversion connector is required to connect GX30 with Communication Box since the cable connector of Communication Box has 16 pins.

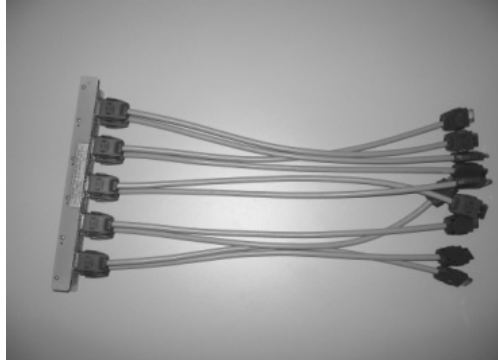

Figure 18

2) Connecting handset to a PC**A) Using a cable for upgrading**

1. Connect the cable to a PC.
2. Connect the cable to handset.
3. The photo below shows handset connected to a PC.



Figure 19

B) Using Communication Box

1. Connect a PC to Communication Box via a serial cable.
2. Connect the AC charger to Communication Box and then plug it into the outlet.
All SET POWER SW on Communication Box must be turned off.
3. Connect the conversion connector to Communication Box Cables.
Connect the conversion connector in the following order, label side up.
From upper right end: Cable No. 1, 3, 5, 7, and 9.
From lower right end: Cable No. 2, 4, 6, 8, and 10.

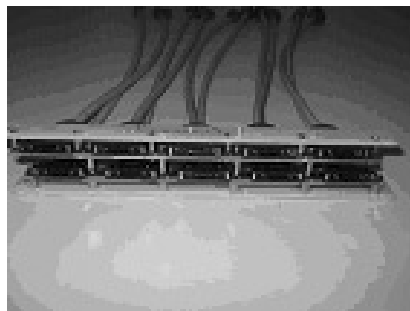

Figure 20

4. The photo below shows the conversion connector connected to Communication Box Cable 1.

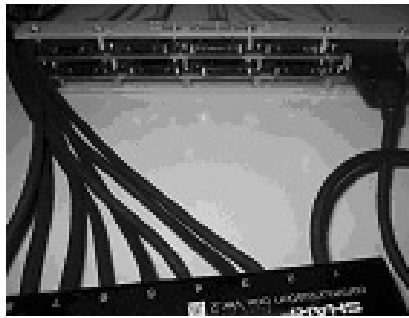

Figure 21

5. Connect the other end of the conversion connector to handset.



Figure 22

6. The photo below shows handset, Communication Box and a PC (all connected).
Make sure handset and Communication Box Cable 1 are connected via the conversion connector.

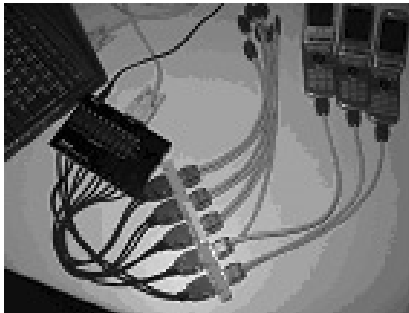

Figure 23

[Note]

Handset must be turned off before making any connections.

Press and hold the Power key to turn off handset.

Do not turn off in other ways. Malfunction may occur and the MOT file rewrite operation may fail.

Make sure the handset battery is sufficiently charged.

If the battery is low, the MOT file rewrite operation may fail.

Charge the battery before the operation.

Disconnect the AC charger from a cable for upgrading.

When rewriting MOT files using the upgrading tool, do not connect the AC charger to the cable.

If you connect the cable connected to the AC charger to handset, charging starts and the MOT file rewrite operation is interrupted.

All SET POWER SW on Communication Box must be turned off.

If handset is connected with SET POWER SW turned on, charging starts and the MOT file rewrite operation is interrupted.

Make sure handset and Communication Box Cable 1 are connected via the conversion connector.

(When using Communication Box, the only handset connected to Cable 1 can be operated on the PC.)

4.4.2 Rewriting MOT files

This section describes how to rewrite MOT files using the upgrading tool.

1) Activating Software

1. Double click the shortcut icon on your desktop or click "The GX30 Upgrading Tool" on the Start menu.

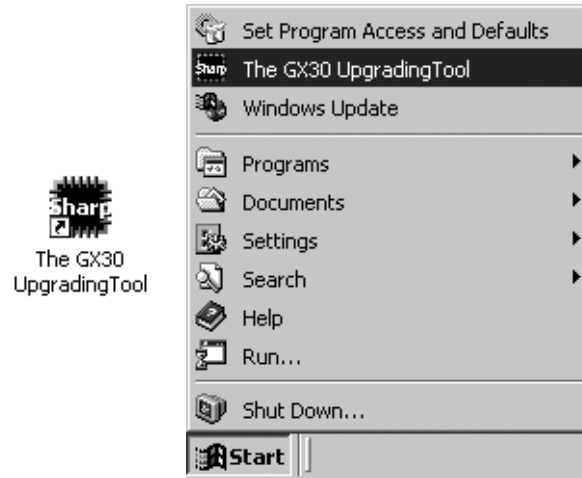

Figure 24

2. The upgrading tool is activated.



Figure 25

[Note]

Disable the power saving mode before rewriting MOT files.

If the power saving mode is active, the rewrite operation may fail depending on the PC.

2) Selecting options and COM port

1. Uncheck the check box when using a cable for upgrading. Leave it checked when using Communication Box.
2. To initialize user area, check the File System Initialize check box. (User data will be deleted and the handset status will return to the default.)
3. Click here and in the pull-down list, select a communications port where the cable or Communication Box is connected.

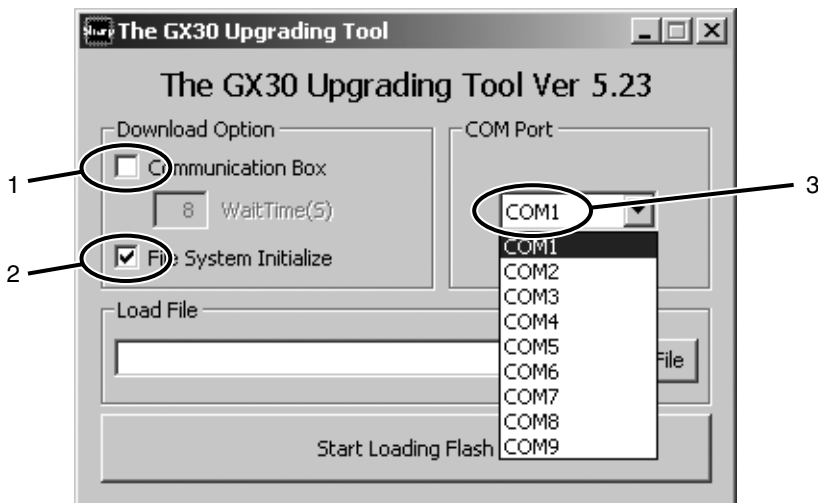

Figure 26

When using Communication Box, set Wait Time.

Check the Communication Box check box to adjust Wait Time (default: 8 seconds). The time to delete the program data varies between handsets. Handsets wait for the set Wait Time until the whole process is completed. If an error occurs, increase the value.

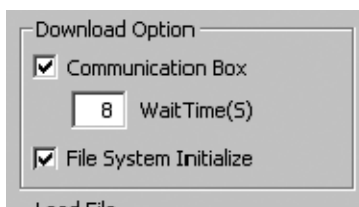

Figure 27

[Notes for the Wait Time setting]

When the set value is smaller than the default (8), the message on the left appears alerting you a possible error. Click the "OK" button to proceed, and click the "Cancel" button to change the value.

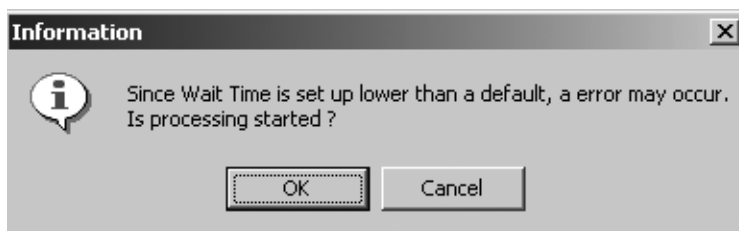

Figure 28

You can shorten time for the MOT file rewrite operation by selecting a smaller value for Wait Time.

Example: Time to rewrite two MOT files at a time.

At the default setting (8 seconds), rewrite time is approximately one hour.

If the value is set to 1, the rewrite time will be reduced to approximately 30 minutes.

If an error occurs at 1, increase the value.

The error screen will appear on handsets No. 2 to No.10.

If this screen appears, increase Wait Time and retry.

Error screen

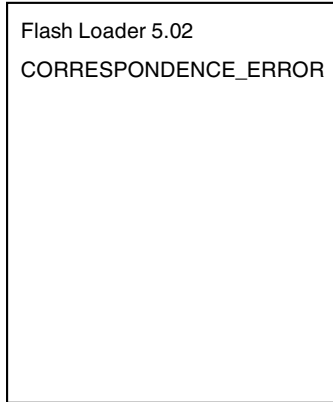

Figure 29

When the File System Initialize check box is checked, a confirmation message appears.

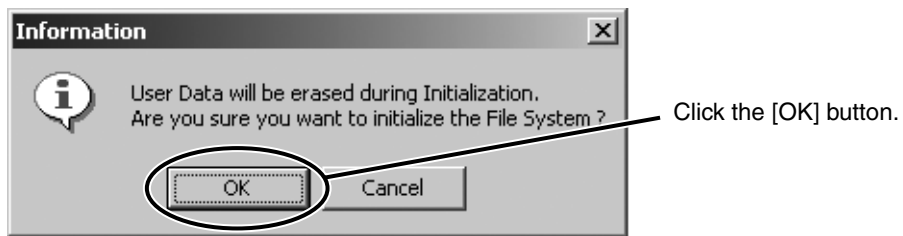

Figure 30

[Note]

When you check File System Initialize check box and click the "OK" button, handset status returns to the default. In this case, user data is initialized after the MOT file rewrite operation. Uncheck the check box to avoid this.

3) Selecting a MOT file

1. Click the "Select File" button.
The Open dialog box appears.



Figure 31

[Open dialog box]

2. Click the "▼" button to open a desired folder.
3. A Motorola file (.mot) in the folder appears. Click a file to write in.
4. Click the "Open" button to open the file.

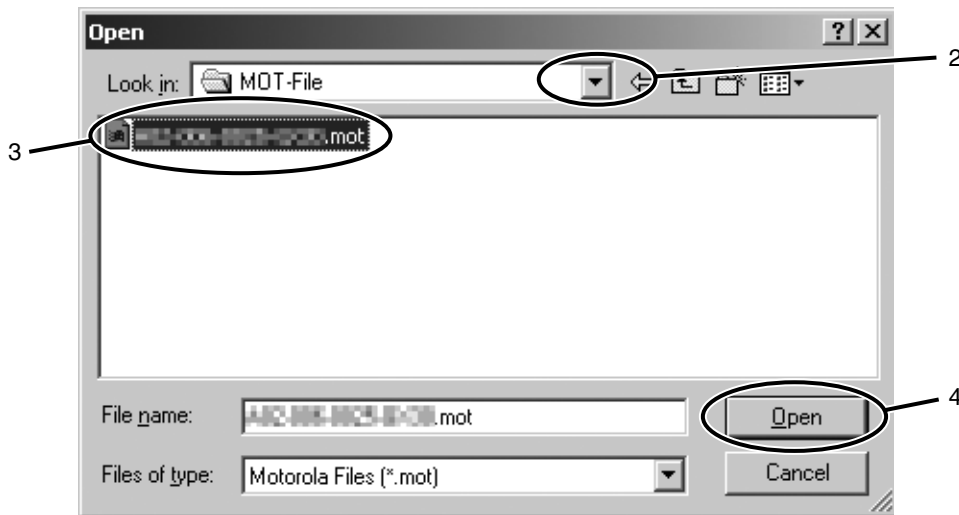

Figure 32

[Note]

Make sure to select a MOT file.

If the File name field is blank, you cannot rewrite a MOT file.

Use MOT files in the hard disk.

If the selected MOT file is stored in other locations, an error message appears and you cannot complete the rewrite operation.

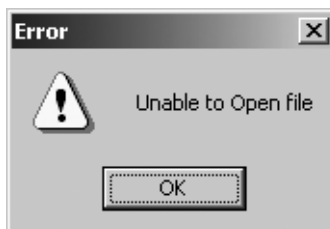

Figure 33

To use MOT files on CDs or on the network, copy or download them to the hard disk first.

4) Rewriting a MOT file

Click the "Start Loading Flash" button to start rewriting.



Figure 34

1. "Press Power Button" appears.
 <When using a cable for upgrading>
 Hold down the Power key.
 <When using the Communication Box>
 Turn on handsets from No.10 down to No.1 (turn on only the handsets you are using).



Figure 35

2. "Keep Pressing Power Button" appears.
 <When using a cable for upgrading>
 Hold down the Power key until the "Keep Pressing Power Button" disappears.
 <When using the Communication Box>
 Leave the handsets turned on.



Figure 36

3. The MOT file rewrite operation starts.
 - <When using a cable for upgrading>
 - When "Keep Pressing Power Button" disappears, release the Power key.
 - <When using the Communication Box>
 - Leave the handsets turned on.



Figure 37

4. When the rewrite operation starts, handset display screen shows the software version and process of communications with the PC.

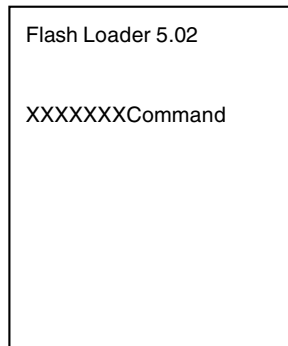

Figure 38

Canceling the ongoing rewrite operation:

Click the "QUIT" button.

To rewrite MOT files later, remove and install the battery first.

[Notes for the use of a cable for upgrading]

1. Disconnect the AC charger from the cable. Otherwise charging starts and the MOT file rewrite operation is interrupted.
2. Make sure the handset battery is sufficiently charged.
 - If the battery is low, the rewrite operation may fail. Charge the battery before the operation.
3. If the ongoing rewrite operation is canceled, or interrupted by an error, remove and reinstall the battery and retry.

[Notes for the use of the Communication Box]

1. When "Press Power Button!" appears, turn on handsets from No.10 down to No.1. If the handset No.1 is first turned on, the rewrite on handsets No. 2 to No. 10 operation will fail.
2. The time to delete the program data varies between handsets. If the process fails at the default Wait Time (8 seconds), increase the value. Consequently, this will increase the time to complete the rewrite operation.

5) Checking the value of SUM

When the rewrite operation is completed, a confirmation message appears with SUM.

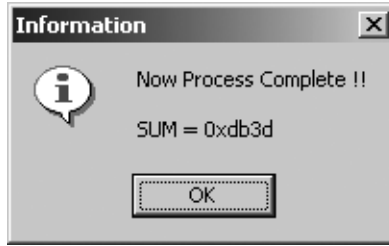

Figure 39

SUM also appears on handset.

<When using a cable for upgrading>

After 8 seconds, SUM disappears.

<When using Communication Box>

When SET POWER SW is turned off, SUM disappears.

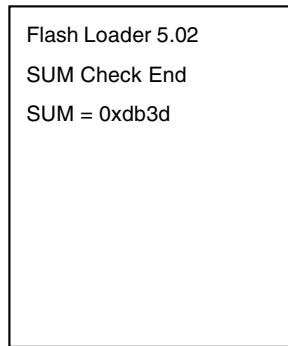

Figure 40

Make sure SUM is the same between the PC and handset.

The same SUM means that the rewrite operation is completed properly. If the value is different, try again to ensure completion of the operation.

If the MOT file rewrite operation fails, an error message appears on handset.

* The screen shot on the left shows an error in erasing Flash data.

"ADR" and "STR" appear only when an error occurs in the FLASH-related operation.

Start over the MOT file rewrite operation.

<When other error messages appear>

Find the message in [4.4.3.2) **Error messages for Loading loader** (see page 2-18)], and follow the instructions.

Error screen

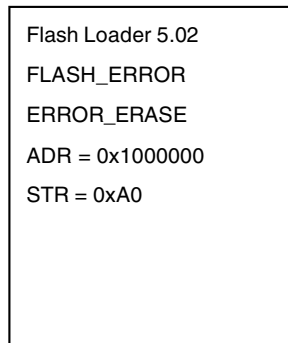

Figure 41

6) After the operation

Disconnect the cable for upgrading from handset.

When using the Communication Box, turn off SET POWER SW and then disconnect the cable from handset.

7) Initializing only the file system

Follow the instructions below to initialize only the file system.

(User data will be deleted and the handset status will return to the default.)

*** Perform this procedure when the handset does not turn on.**

1. Check the File System Initialize check box.
2. Leave the Load File text box blank.
3. Click the "Start Loading Flash" button.



Figure 42

For further operations, refer to [4.4.2.4] **Rewriting a MOT file** (see page 2-14) or [4.4.2.5] **Checking the value of SUM** (see page 2-16).

4.4.3 Error message list

Below is the list of error messages for the upgrading tool (on the PC side) and Loading loader (on the handset side).

1) Error messages for the upgrading tool (on the PC side)

No.	Message	Descriptions/Instructions
1	Select a file for Downloading or check the box of Initializing.	Load File is not set. Select a MOT file.
2	Unable to open file.	Failed to open the MOT file. Start over the rewrite operation.
3	You need to set the Wait Time!	WaitTime (S) is not set. Set WaitTime (S) value.
4	The file you selected is unsuitable for Upgrading.	The selected file cannot be rewritten for upgrading. Select an appropriate MOT file.
5	Cannot Setup COM port.	The selected COM port does not exist or is used for other operations. Select a COM port connected to the PC cable.
6	RAM Loader not responding to Commands.	No response from Loading loader. Start over the rewrite operation.
7	RAM Loader responding Parameter Error.	Information sent from the PC is illegal. Reinstall the upgrading tool. Start over the rewrite operation.
8	RAM Loader responding Flash Error (XXXX).	Failed to initialize FLASH ROM in (XXXX). Start over the rewrite operation.
9	Correspondence Error.	Undefined response from Loading loader. Start over the rewrite operation.

2) Error messages for Loading loader (on the handset side)

No.	Message	Descriptions/Instructions
1	FLASH_ERROR	An error in Flash Rom. Start over the rewrite operation.
2	ERROR_PARAM	The upgrading tool is damaged. Uninstall and reinstall the upgrading tool, and start over the rewrite operation.
3	ERROR_WPROTECT	Flash Rom is protected. Battery may be too low. Use a sufficiently charged battery and start over the rewrite operation.
4	ERROR_READ	Failed to read Flash Rom data and the operation was aborted. Start over the rewrite operation.
5	ERROR_WRITE	Failed to write to Flash Rom and the operation was aborted. Start over the rewrite operation.
6	ERROR_ERASE	Failed to erase Flash Rom data and the operation was aborted. Start over the rewrite operation.
7	ERROR_VERIFY	The rewrite operation was aborted since there was a mismatch between data written to Flash Rom and that written to handset. Start over the rewrite operation.
8	ERROR_RWE_TMOUT	Communication was terminated since there was no response from Flash Rom for a certain period of time. Start over the rewrite operation.
9	CORRESPONDENCE_ERROR	Communication was terminated since serial data communication failed. Start over the rewrite operation.
10	ADR = XXXXXXXX	Indicates the address of Flash (the error source).
11	STR =XX	Indicates the status of Flash (the error source).

* When No.1 occurs, handset screen shows error messages for No.2 to No.8 as well as the address (No.10) and status (No.11) of the error source at the same time.

4.5. RF calibration & check

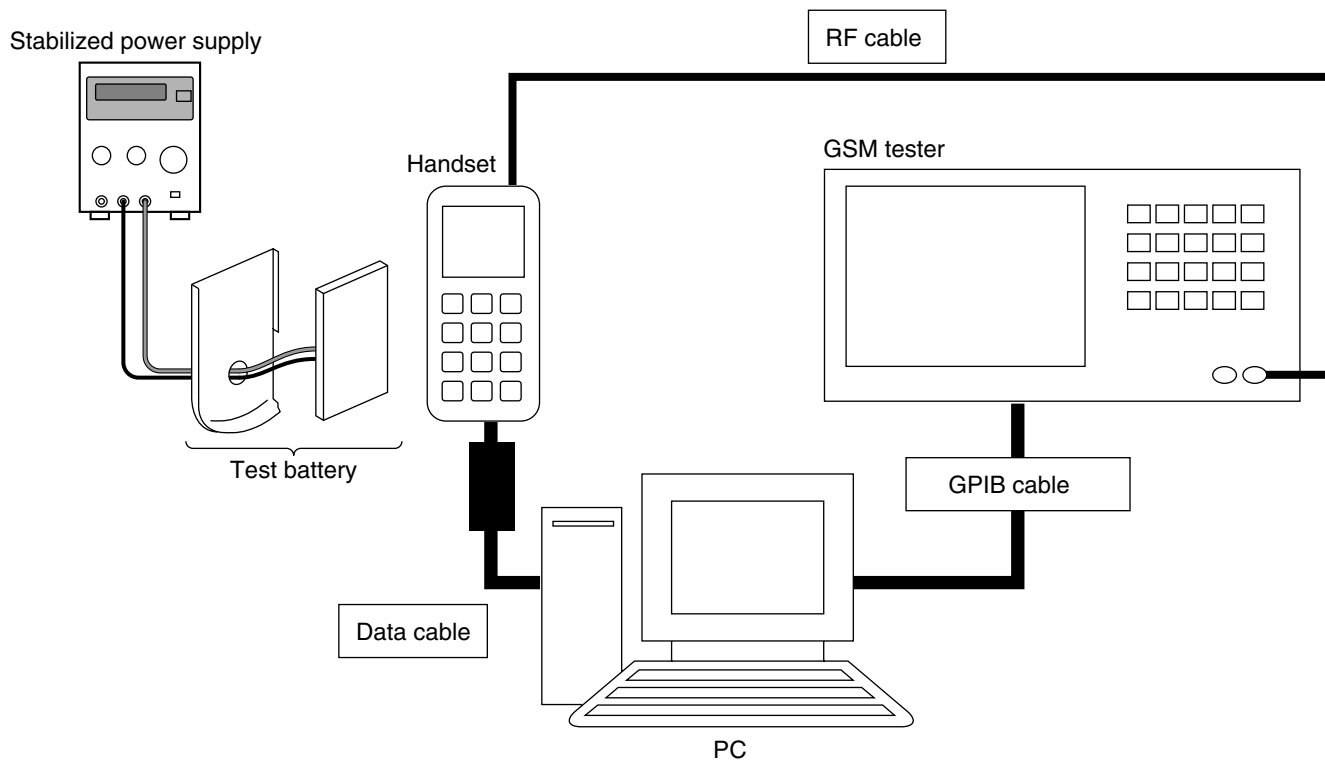

Figure 43

4.5.1 Preparation

- Connect PC and GSM tester with a GPIB cable.
- Connect PC and handset with a Data cable. (Use a test battery or one close.)
- Connect a RF cable of GSM tester to handset.

4.5.2 Default setting for the program.

- Activate the program and set defaults.

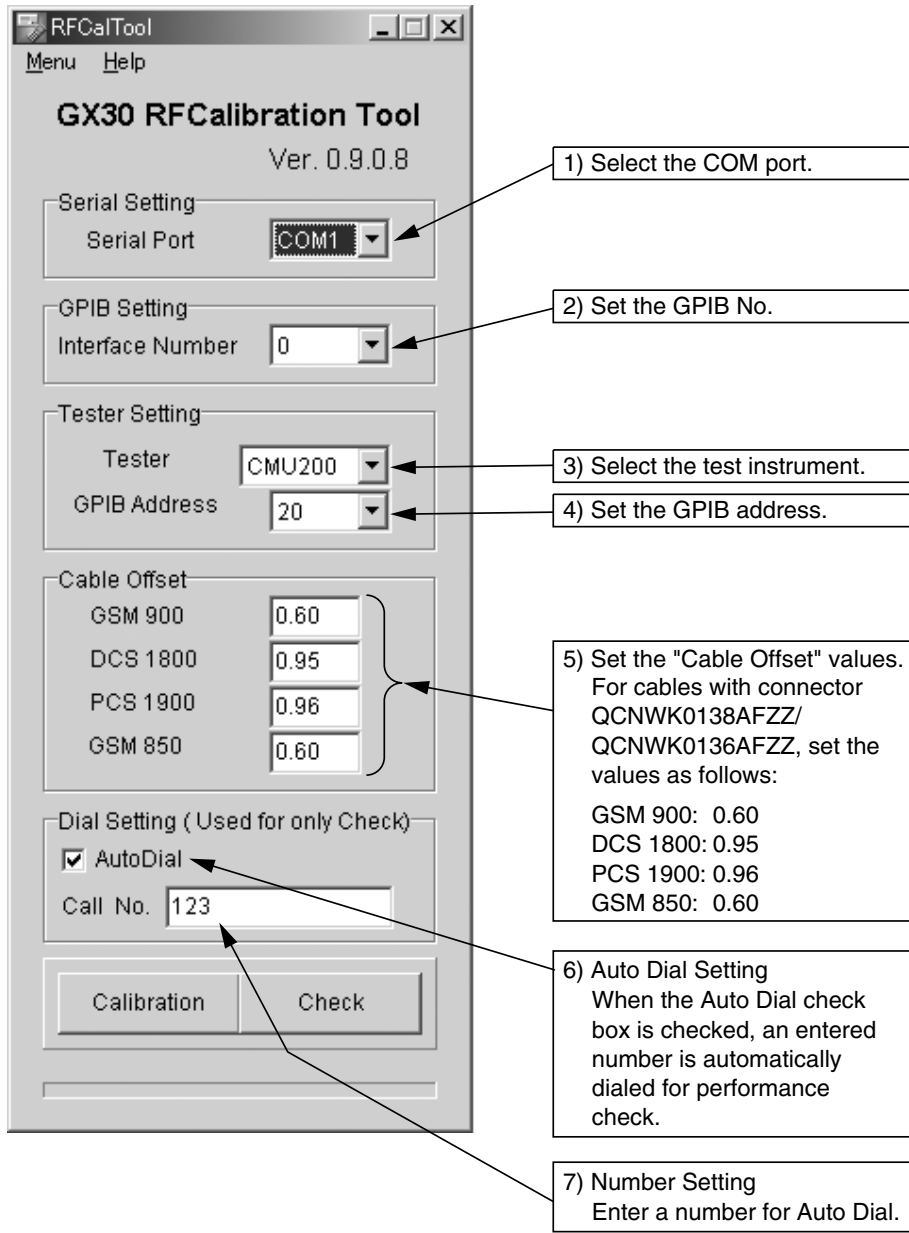

Figure 44

4.5.3 RF calibration

1. Apply 4 V using a stabilized power supply and turn on the handset.
2. Start "RF calibration & check" on SPST and click "Calibration".
3. When initialization is complete, click "OK".



Figure 45

4. Apply 4 V using a stabilized power supply and turn on the handset. After the handset enters Standby mode, lower the voltage to 3.7 V, click "OK".



Figure 46

5. Make sure the handset is on and click "OK".
(Adjustment starts.)

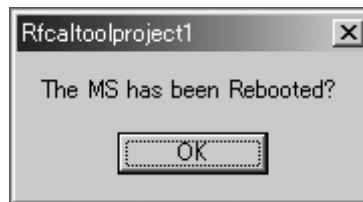

Figure 47

6. Click "OK".



Figure 48

7. The initial screen returns.

<Note>

The following appears when the handset software (mot) is outdated. Upgrade to a new version.



Figure 49

4.5.4 RF performance check

1. Apply 4 V using a stabilized power supply and turn on the handset.
2. Start "RF calibration & check" on SPST and click "Check".
3. When initialization is complete, click "OK".



Figure 50

4. Apply 4 V using a stabilized power supply and turn on the handset. After the handset enters Standby mode, lower the voltage to 3.7 V, enter the PIN code and click "OK".



Figure 51

5. Make sure the handset is in the idle mode and click "OK".

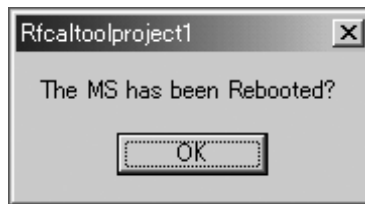

Figure 52

6. RF performance check is complete. Click "Save As..." and name the file to save the result. Click "OK" to exit.

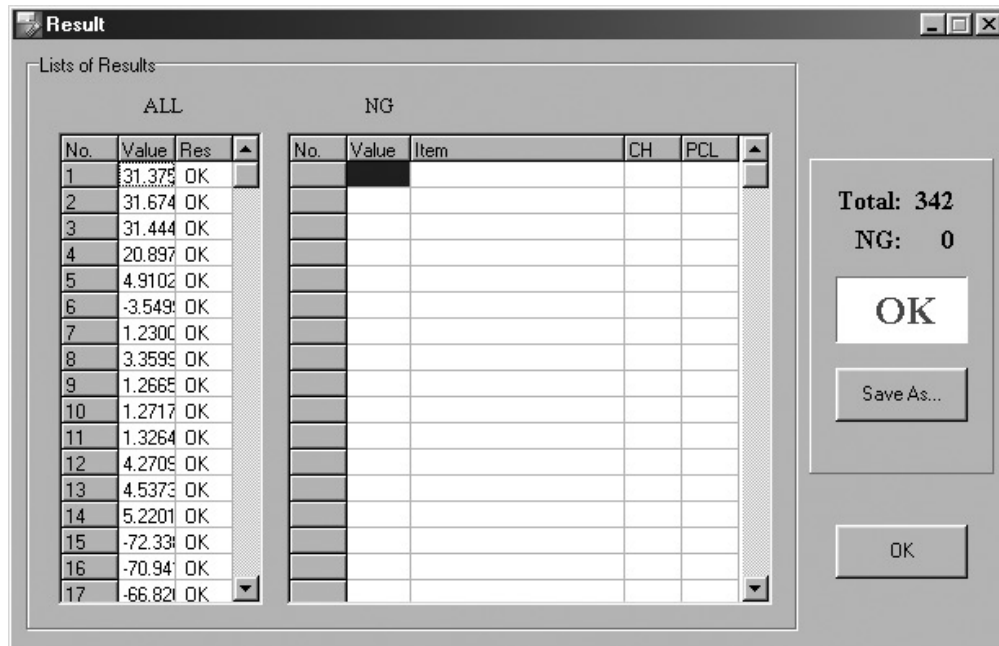

Figure 53

The following will be displayed in case of failure.
See the attachment 2 for troubleshooting.

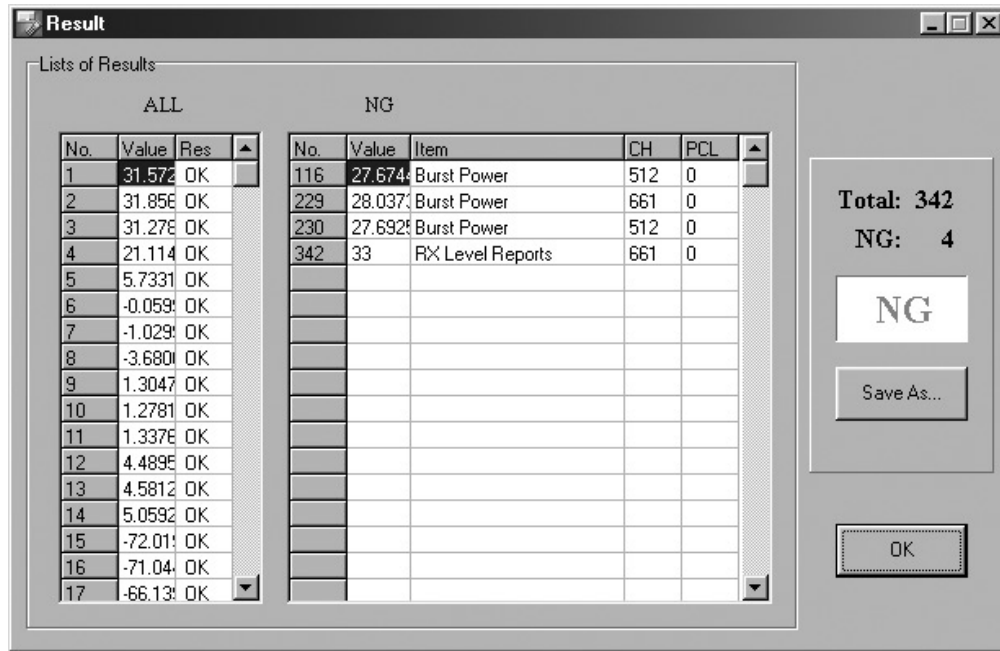

Figure 54

7. Click "OK".



Figure 55

8. The initial screen returns.

Attachment 2
Whole inspection list by RF performance check.

Band	Sending/Receive	No.	Item to be inspected	Channel	PCL
GSM 900	Tx	1	Burst Power	37CH	PCL5
		2	Burst Power	975CH	PCL5
		3	Burst Power	124CH	PCL5
		4	Burst Power	37CH	PCL11
		5	Burst Power	37CH	PCL19
		6	Frequency Error	37CH	PCL5
		7	Frequency Error	975CH	PCL5
		8	Frequency Error	124CH	PCL5
		9	Phase Error (RMS)	37CH	PCL5
		10	Phase Error (RMS)	975CH	PCL5
		11	Phase Error (RMS)	124CH	PCL5
		12	Phase Error (Peak)	37CH	PCL5
		13	Phase Error (Peak)	975CH	PCL5
		14	Phase Error (Peak)	124CH	PCL5
		15	Mod_spectrum -800	37CH	PCL5
		16	Mod_spectrum -600	37CH	PCL5
		17	Mod_spectrum -400	37CH	PCL5
		18	Mod_spectrum -250	37CH	PCL5
		19	Mod_spectrum -200	37CH	PCL5
		20	Mod_spectrum +200	37CH	PCL5
		21	Mod_spectrum +250	37CH	PCL5
		22	Mod_spectrum +400	37CH	PCL5
		23	Mod_spectrum +600	37CH	PCL5
		24	Mod_spectrum +800	37CH	PCL5
		25	Mod_spectrum -800	975CH	PCL5
		26	Mod_spectrum -600	975CH	PCL5
		27	Mod_spectrum -400	975CH	PCL5
		28	Mod_spectrum -250	975CH	PCL5
		29	Mod_spectrum -200	975CH	PCL5
		30	Mod_spectrum +200	975CH	PCL5
		31	Mod_spectrum +250	975CH	PCL5
		32	Mod_spectrum +400	975CH	PCL5
		33	Mod_spectrum +600	975CH	PCL5
		34	Mod_spectrum +800	975CH	PCL5
		35	Mod_spectrum -800	124CH	PCL5
		36	Mod_spectrum -600	124CH	PCL5
		37	Mod_spectrum -400	124CH	PCL5
		38	Mod_spectrum -250	124CH	PCL5
		39	Mod_spectrum -200	124CH	PCL5
		40	Mod_spectrum +200	124CH	PCL5
		41	Mod_spectrum +250	124CH	PCL5
		42	Mod_spectrum +400	124CH	PCL5
		43	Mod_spectrum +600	124CH	PCL5
		44	Mod_spectrum +800	124CH	PCL5
		45	Mod_spectrum -800	37CH	PCL11
		46	Mod_spectrum -600	37CH	PCL11
		47	Mod_spectrum -400	37CH	PCL11
		48	Mod_spectrum -250	37CH	PCL11
		49	Mod_spectrum -200	37CH	PCL11
		50	Mod_spectrum +200	37CH	PCL11
		51	Mod_spectrum +250	37CH	PCL11
		52	Mod_spectrum +400	37CH	PCL11
		53	Mod_spectrum +600	37CH	PCL11
		54	Mod_spectrum +800	37CH	PCL11
		55	Mod_spectrum -800	37CH	PCL19
		56	Mod_spectrum -600	37CH	PCL19
		57	Mod_spectrum -400	37CH	PCL19
		58	Mod_spectrum -250	37CH	PCL19
		59	Mod_spectrum -200	37CH	PCL19
		60	Mod_spectrum +200	37CH	PCL19

Band	Sending/Receive	No.	Item to be inspected	Channel	PCL				
		61	Mod_spectrum +250	37CH	PCL19				
		62	Mod_spectrum +400	37CH	PCL19				
		63	Mod_spectrum +600	37CH	PCL19				
		64	Mod_spectrum +800	37CH	PCL19				
		65	Switch_Spectrum -1800	37CH	PCL5				
		66	Switch_Spectrum -1200	37CH	PCL5				
		67	Switch_Spectrum -600	37CH	PCL5				
		68	Switch_Spectrum -400	37CH	PCL5				
		69	Switch_Spectrum +400	37CH	PCL5				
		70	Switch_Spectrum +600	37CH	PCL5				
		71	Switch_Spectrum +1200	37CH	PCL5				
		72	Switch_Spectrum +1800	37CH	PCL5				
		73	Switch_Spectrum -1800	975CH	PCL5				
		74	Switch_Spectrum -1200	975CH	PCL5				
		75	Switch_Spectrum -600	975CH	PCL5				
		76	Switch_Spectrum -400	975CH	PCL5				
		77	Switch_Spectrum +400	975CH	PCL5				
		78	Switch_Spectrum +600	975CH	PCL5				
		79	Switch_Spectrum +1200	975CH	PCL5				
		80	Switch_Spectrum +1800	975CH	PCL5				
		81	Switch_Spectrum -1800	124CH	PCL5				
		82	Switch_Spectrum -1200	124CH	PCL5				
		83	Switch_Spectrum -600	124CH	PCL5				
		84	Switch_Spectrum -400	124CH	PCL5				
		85	Switch_Spectrum +400	124CH	PCL5				
		86	Switch_Spectrum +600	124CH	PCL5				
		87	Switch_Spectrum +1200	124CH	PCL5				
		88	Switch_Spectrum +1800	124CH	PCL5				
		89	Switch_Spectrum -1800	37CH	PCL11				
		90	Switch_Spectrum -1200	37CH	PCL11				
		91	Switch_Spectrum -600	37CH	PCL11				
		92	Switch_Spectrum -400	37CH	PCL11				
		93	Switch_Spectrum +400	37CH	PCL11				
		94	Switch_Spectrum +600	37CH	PCL11				
		95	Switch_Spectrum +1200	37CH	PCL11				
		96	Switch_Spectrum +1800	37CH	PCL11				
		97	Switch_Spectrum -1800	37CH	PCL19				
		98	Switch_Spectrum -1200	37CH	PCL19				
		99	Switch_Spectrum -600	37CH	PCL19				
		100	Switch_Spectrum -400	37CH	PCL19				
		101	Switch_Spectrum +400	37CH	PCL19				
		102	Switch_Spectrum +600	37CH	PCL19				
		103	Switch_Spectrum +1200	37CH	PCL19				
		104	Switch_Spectrum +1800	37CH	PCL19				
		105	Burst Timing	37CH	PCL5				
		106	Burst Timing	975CH	PCL5				
		107	Burst Timing	124CH	PCL5				
		108	Burst Timing	37CH	PCL11				
		109	Burst Timing	37CH	PCL19				
			Rx	110	Rx Sensitivity	37CH	PCL5		
				111	Rx Sensitivity	975CH	PCL5		
				112	Rx Sensitivity	124CH	PCL5		
				113	Usable Receiver Level	37CH	PCL5		
				114	Rx Level Reports	37CH	PCL5		
				DCS	Tx	115	Burst Power	699CH	PCL0
						116	Burst Power	512CH	PCL0
		117	Burst Power			885CH	PCL0		
		118	Burst Power			699CH	PCL5		
		119	Burst Power			699CH	PCL15		
		120	Frequency Error			699CH	PCL0		
		121	Frequency Error			512CH	PCL0		
		122	Frequency Error			885CH	PCL0		

Band	Sending/Receive	No.	Item to be inspected	Channel	PCL	Band	Sending/Receive	No.	Item to be inspected	Channel	PCL
		123	Phase Error (RMS)	699CH	PCL0			185	Switch_Spectrum +1200	699CH	PCL0
		124	Phase Error (RMS)	512CH	PCL0			186	Switch_Spectrum +1800	699CH	PCL0
		125	Phase Error (RMS)	885CH	PCL0			187	Switch_Spectrum -1800	512CH	PCL0
		126	Phase Error (Peak)	699CH	PCL0			188	Switch_Spectrum -1200	512CH	PCL0
		127	Phase Error (Peak)	512CH	PCL0			189	Switch_Spectrum -600	512CH	PCL0
		128	Phase Error (Peak)	885CH	PCL0			190	Switch_Spectrum -400	512CH	PCL0
		129	Mod_spectrum -800	699CH	PCL0			191	Switch_Spectrum +400	512CH	PCL0
		130	Mod_spectrum -600	699CH	PCL0			192	Switch_Spectrum +600	512CH	PCL0
		131	Mod_spectrum -400	699CH	PCL0			193	Switch_Spectrum +1200	512CH	PCL0
		132	Mod_spectrum -250	699CH	PCL0			194	Switch_Spectrum +1800	512CH	PCL0
		133	Mod_spectrum -200	699CH	PCL0			195	Switch_Spectrum -1800	885CH	PCL0
		134	Mod_spectrum +200	699CH	PCL0			196	Switch_Spectrum -1200	885CH	PCL0
		135	Mod_spectrum +250	699CH	PCL0			197	Switch_Spectrum -600	885CH	PCL0
		136	Mod_spectrum +400	699CH	PCL0			198	Switch_Spectrum -400	885CH	PCL0
		137	Mod_spectrum +600	699CH	PCL0			199	Switch_Spectrum +400	885CH	PCL0
		138	Mod_spectrum +800	699CH	PCL0			200	Switch_Spectrum +600	885CH	PCL0
		139	Mod_spectrum -800	512CH	PCL0			201	Switch_Spectrum +1200	885CH	PCL0
		140	Mod_spectrum -600	512CH	PCL0			202	Switch_Spectrum +1800	885CH	PCL0
		141	Mod_spectrum -400	512CH	PCL0			203	Switch_Spectrum -1800	699CH	PCL5
		142	Mod_spectrum -250	512CH	PCL0			204	Switch_Spectrum -1200	699CH	PCL5
		143	Mod_spectrum -200	512CH	PCL0			205	Switch_Spectrum -600	699CH	PCL5
		144	Mod_spectrum +200	512CH	PCL0			206	Switch_Spectrum -400	699CH	PCL5
		145	Mod_spectrum +250	512CH	PCL0			207	Switch_Spectrum +400	699CH	PCL5
		146	Mod_spectrum +400	512CH	PCL0			208	Switch_Spectrum +600	699CH	PCL5
		147	Mod_spectrum +600	512CH	PCL0			209	Switch_Spectrum +1200	699CH	PCL5
		148	Mod_spectrum +800	512CH	PCL0			210	Switch_Spectrum +1800	699CH	PCL5
		149	Mod_spectrum -800	885CH	PCL0			211	Switch_Spectrum -1800	699CH	PCL15
		150	Mod_spectrum -600	885CH	PCL0			212	Switch_Spectrum -1200	699CH	PCL15
		151	Mod_spectrum -400	885CH	PCL0			213	Switch_Spectrum -600	699CH	PCL15
		152	Mod_spectrum -250	885CH	PCL0			214	Switch_Spectrum -400	699CH	PCL15
		153	Mod_spectrum -200	885CH	PCL0			215	Switch_Spectrum +400	699CH	PCL15
		154	Mod_spectrum +200	885CH	PCL0			216	Switch_Spectrum +600	699CH	PCL15
		155	Mod_spectrum +250	885CH	PCL0			217	Switch_Spectrum +1200	699CH	PCL15
		156	Mod_spectrum +400	885CH	PCL0			218	Switch_Spectrum +1800	699CH	PCL15
		157	Mod_spectrum +600	885CH	PCL0			219	Burst Timing	699CH	PCL0
		158	Mod_spectrum +800	885CH	PCL0			220	Burst Timing	512CH	PCL0
		159	Mod_spectrum -800	699CH	PCL5			221	Burst Timing	885CH	PCL0
		160	Mod_spectrum -600	699CH	PCL5			222	Burst Timing	699CH	PCL5
		161	Mod_spectrum -400	699CH	PCL5			223	Burst Timing	699CH	PCL15
		162	Mod_spectrum -250	699CH	PCL5		Rx	224	Rx Sensitivity	699CH	PCL0
		163	Mod_spectrum -200	699CH	PCL5			225	Rx Sensitivity	512CH	PCL0
		164	Mod_spectrum +200	699CH	PCL5			226	Rx Sensitivity	885CH	PCL0
		165	Mod_spectrum +250	699CH	PCL5			227	Usable Receiver Level	699CH	PCL0
		166	Mod_spectrum +400	699CH	PCL5			228	Rx Level Reports	699CH	PCL0
		167	Mod_spectrum +600	699CH	PCL5	PCS	Tx	229	Burst Power	661CH	PCL0
		168	Mod_spectrum +800	699CH	PCL5			230	Burst Power	512CH	PCL0
		169	Mod_spectrum -800	699CH	PCL15			231	Burst Power	810CH	PCL0
		170	Mod_spectrum -600	699CH	PCL15			232	Burst Power	661CH	PCL5
		171	Mod_spectrum -400	699CH	PCL15			233	Burst Power	661CH	PCL15
		172	Mod_spectrum -250	699CH	PCL15			234	Frequency Error	661CH	PCL0
		173	Mod_spectrum -200	699CH	PCL15			235	Frequency Error	512CH	PCL0
		174	Mod_spectrum +200	699CH	PCL15			236	Frequency Error	810CH	PCL0
		175	Mod_spectrum +250	699CH	PCL15			237	Phase Error (RMS)	661CH	PCL0
		176	Mod_spectrum +400	699CH	PCL15			238	Phase Error (RMS)	512CH	PCL0
		177	Mod_spectrum +600	699CH	PCL15			239	Phase Error (RMS)	810CH	PCL0
		178	Mod_spectrum +800	699CH	PCL15			240	Phase Error (Peak)	661CH	PCL0
		179	Switch_Spectrum -1800	699CH	PCL0			241	Phase Error (Peak)	512CH	PCL0
		180	Switch_Spectrum -1200	699CH	PCL0			242	Phase Error (Peak)	810CH	PCL0
		181	Switch_Spectrum -600	699CH	PCL0			243	Mod_spectrum -800	661CH	PCL0
		182	Switch_Spectrum -400	699CH	PCL0			244	Mod_spectrum -600	661CH	PCL0
		183	Switch_Spectrum +400	699CH	PCL0			245	Mod_spectrum -400	661CH	PCL0
		184	Switch_Spectrum +600	699CH	PCL0			246	Mod_spectrum -250	661CH	PCL0

Band	Sending/Receive	No.	Item to be inspected	Channel	PCL	Band	Sending/Receive	No.	Item to be inspected	Channel	PCL
		247	Mod_spectrum -200	661CH	PCL0			309	Switch_Spectrum -1800	810CH	PCL0
		248	Mod_spectrum +200	661CH	PCL0			310	Switch_Spectrum -1200	810CH	PCL0
		249	Mod_spectrum +250	661CH	PCL0			311	Switch_Spectrum -600	810CH	PCL0
		250	Mod_spectrum +400	661CH	PCL0			312	Switch_Spectrum -400	810CH	PCL0
		251	Mod_spectrum +600	661CH	PCL0			313	Switch_Spectrum +400	810CH	PCL0
		252	Mod_spectrum +800	661CH	PCL0			314	Switch_Spectrum +600	810CH	PCL0
		253	Mod_spectrum -800	512CH	PCL0			315	Switch_Spectrum +1200	810CH	PCL0
		254	Mod_spectrum -600	512CH	PCL0			316	Switch_Spectrum +1800	810CH	PCL0
		255	Mod_spectrum -400	512CH	PCL0			317	Switch_Spectrum -1800	661CH	PCL5
		256	Mod_spectrum -250	512CH	PCL0			318	Switch_Spectrum -1200	661CH	PCL5
		257	Mod_spectrum -200	512CH	PCL0			319	Switch_Spectrum -600	661CH	PCL5
		258	Mod_spectrum +200	512CH	PCL0			320	Switch_Spectrum -400	661CH	PCL5
		259	Mod_spectrum +250	512CH	PCL0			321	Switch_Spectrum +400	661CH	PCL5
		260	Mod_spectrum +400	512CH	PCL0			322	Switch_Spectrum +600	661CH	PCL5
		261	Mod_spectrum +600	512CH	PCL0			323	Switch_Spectrum +1200	661CH	PCL5
		262	Mod_spectrum +800	512CH	PCL0			324	Switch_Spectrum +1800	661CH	PCL5
		263	Mod_spectrum -800	810CH	PCL0			325	Switch_Spectrum -1800	661CH	PCL15
		264	Mod_spectrum -600	810CH	PCL0			326	Switch_Spectrum -1200	661CH	PCL15
		265	Mod_spectrum -400	810CH	PCL0			327	Switch_Spectrum -600	661CH	PCL15
		266	Mod_spectrum -250	810CH	PCL0			328	Switch_Spectrum -400	661CH	PCL15
		267	Mod_spectrum -200	810CH	PCL0			329	Switch_Spectrum +400	661CH	PCL15
		268	Mod_spectrum +200	810CH	PCL0			330	Switch_Spectrum +600	661CH	PCL15
		269	Mod_spectrum +250	810CH	PCL0			331	Switch_Spectrum +1200	661CH	PCL15
		270	Mod_spectrum +400	810CH	PCL0			332	Switch_Spectrum +1800	661CH	PCL15
		271	Mod_spectrum +600	810CH	PCL0			333	Burst Timing	661CH	PCL0
		272	Mod_spectrum +800	810CH	PCL0			334	Burst Timing	512CH	PCL0
		273	Mod_spectrum -800	661CH	PCL5			335	Burst Timing	810CH	PCL0
		274	Mod_spectrum -600	661CH	PCL5			336	Burst Timing	661CH	PCL5
		275	Mod_spectrum -400	661CH	PCL5			337	Burst Timing	661CH	PCL15
		276	Mod_spectrum -250	661CH	PCL5		Rx	338	Rx Sensitivity	661CH	PCL0
		277	Mod_spectrum -200	661CH	PCL5			339	Rx Sensitivity	512CH	PCL0
		278	Mod_spectrum +200	661CH	PCL5			340	Rx Sensitivity	810CH	PCL0
		279	Mod_spectrum +250	661CH	PCL5			341	Usable Receiver Level	661CH	PCL0
		280	Mod_spectrum +400	661CH	PCL5			342	Rx Level Reports	661CH	PCL0
		281	Mod_spectrum +600	661CH	PCL5						
		282	Mod_spectrum +800	661CH	PCL5						
		283	Mod_spectrum -800	661CH	PCL15		GSM	343	Burst Power	190CH	PCL7
		284	Mod_spectrum -600	661CH	PCL15	850	Tx	344	Burst Power	128CH	PCL7
		285	Mod_spectrum -400	661CH	PCL15			345	Burst Power	251CH	PCL7
		286	Mod_spectrum -250	661CH	PCL15			346	Burst Power	190CH	PCL11
		287	Mod_spectrum -200	661CH	PCL15			347	Burst Power	190CH	PCL19
		288	Mod_spectrum +200	661CH	PCL15			348	Burst Power	190CH	PCL7
		289	Mod_spectrum +250	661CH	PCL15			349	Frequency Error	190CH	PCL7
		290	Mod_spectrum +400	661CH	PCL15			350	Frequency Error	128CH	PCL7
		291	Mod_spectrum +600	661CH	PCL15			351	Frequency Error	251CH	PCL7
		292	Mod_spectrum +800	661CH	PCL15			352	Phase Error (RMS)	190CH	PCL7
		293	Switch_Spectrum -1800	661CH	PCL0			353	Phase Error (RMS)	128CH	PCL7
		294	Switch_Spectrum -1200	661CH	PCL0			354	Phase Error (RMS)	251CH	PCL7
		295	Switch_Spectrum -600	661CH	PCL0			355	Phase Error (Peak)	190CH	PCL7
		296	Switch_Spectrum -400	661CH	PCL0			356	Phase Error (Peak)	128CH	PCL7
		297	Switch_Spectrum +400	661CH	PCL0			357	Phase Error (Peak)	251CH	PCL7
		298	Switch_Spectrum +600	661CH	PCL0			358	Mod_spectrum -800	190CH	PCL7
		299	Switch_Spectrum +1200	661CH	PCL0			359	Mod_spectrum -600	190CH	PCL7
		300	Switch_Spectrum +1800	661CH	PCL0			360	Mod_spectrum -400	190CH	PCL7
		301	Switch_Spectrum -1800	512CH	PCL0			361	Mod_spectrum -250	190CH	PCL7
		302	Switch_Spectrum -1200	512CH	PCL0			362	Mod_spectrum -200	190CH	PCL7
		303	Switch_Spectrum -600	512CH	PCL0			363	Mod_spectrum +200	190CH	PCL7
		304	Switch_Spectrum -400	512CH	PCL0			364	Mod_spectrum +250	190CH	PCL7
		305	Switch_Spectrum +400	512CH	PCL0			365	Mod_spectrum +400	190CH	PCL7
		306	Switch_Spectrum +600	512CH	PCL0			366	Mod_spectrum +600	190CH	PCL7
		307	Switch_Spectrum +1200	512CH	PCL0			367	Mod_spectrum +800	190CH	PCL7
		308	Switch_Spectrum +1800	512CH	PCL0			368	Mod_spectrum -800	128CH	PCL7
								369	Mod_spectrum -600	128CH	PCL7
								370	Mod_spectrum -400	128CH	PCL7
									Mod_spectrum -250	128CH	PCL7

Band	Sending/Receive	No.	Item to be inspected	Channel	PCL	Band	Sending/Receive	No.	Item to be inspected	Channel	PCL
		371	Mod_spectrum -200	128CH	PCL7			416	Switch_Spectrum -1200	128CH	PCL7
		372	Mod_spectrum +200	128CH	PCL7			417	Switch_Spectrum -600	128CH	PCL7
		373	Mod_spectrum +250	128CH	PCL7			418	Switch_Spectrum -400	128CH	PCL7
		374	Mod_spectrum +400	128CH	PCL7			419	Switch_Spectrum +400	128CH	PCL7
		375	Mod_spectrum +600	128CH	PCL7			420	Switch_Spectrum +600	128CH	PCL7
		376	Mod_spectrum +800	128CH	PCL7			421	Switch_Spectrum +1200	128CH	PCL7
		377	Mod_spectrum -800	251CH	PCL7			422	Switch_Spectrum +1800	128CH	PCL7
		378	Mod_spectrum -600	251CH	PCL7			423	Switch_Spectrum -1800	251CH	PCL7
		379	Mod_spectrum -400	251CH	PCL7			424	Switch_Spectrum -1200	251CH	PCL7
		380	Mod_spectrum -250	251CH	PCL7			425	Switch_Spectrum -600	251CH	PCL7
		381	Mod_spectrum -200	251CH	PCL7			426	Switch_Spectrum -400	251CH	PCL7
		382	Mod_spectrum +200	251CH	PCL7			427	Switch_Spectrum +400	251CH	PCL7
		383	Mod_spectrum +250	251CH	PCL7			428	Switch_Spectrum +600	251CH	PCL7
		384	Mod_spectrum +400	251CH	PCL7			429	Switch_Spectrum +1200	251CH	PCL7
		385	Mod_spectrum +600	251CH	PCL7			430	Switch_Spectrum +1800	251CH	PCL7
		386	Mod_spectrum +800	251CH	PCL7			431	Switch_Spectrum -1800	190CH	PCL11
		387	Mod_spectrum -800	190CH	PCL11			432	Switch_Spectrum -1200	190CH	PCL11
		388	Mod_spectrum -600	190CH	PCL11			433	Switch_Spectrum -600	190CH	PCL11
		389	Mod_spectrum -400	190CH	PCL11			434	Switch_Spectrum -400	190CH	PCL11
		390	Mod_spectrum -250	190CH	PCL11			435	Switch_Spectrum +400	190CH	PCL11
		391	Mod_spectrum -200	190CH	PCL11			436	Switch_Spectrum +600	190CH	PCL11
		392	Mod_spectrum +200	190CH	PCL11			437	Switch_Spectrum +1200	190CH	PCL11
		393	Mod_spectrum +250	190CH	PCL11			438	Switch_Spectrum +1800	190CH	PCL11
		394	Mod_spectrum +400	190CH	PCL11			439	Switch_Spectrum -1800	190CH	PCL19
		395	Mod_spectrum +600	190CH	PCL11			440	Switch_Spectrum -1200	190CH	PCL19
		396	Mod_spectrum +800	190CH	PCL11			441	Switch_Spectrum -600	190CH	PCL19
		397	Mod_spectrum -800	190CH	PCL19			442	Switch_Spectrum -400	190CH	PCL19
		398	Mod_spectrum -600	190CH	PCL19			443	Switch_Spectrum +400	190CH	PCL19
		399	Mod_spectrum -400	190CH	PCL19			444	Switch_Spectrum +600	190CH	PCL19
		400	Mod_spectrum -250	190CH	PCL19			445	Switch_Spectrum +1200	190CH	PCL19
		401	Mod_spectrum -200	190CH	PCL19			446	Switch_Spectrum +1800	190CH	PCL19
		402	Mod_spectrum +200	190CH	PCL19			447	Burst Timing	190CH	PCL7
		403	Mod_spectrum +250	190CH	PCL19			448	Burst Timing	128CH	PCL7
		404	Mod_spectrum +400	190CH	PCL19			449	Burst Timing	251CH	PCL7
		405	Mod_spectrum +600	190CH	PCL19			450	Burst Timing	190CH	PCL11
		406	Mod_spectrum +800	190CH	PCL19			451	Burst Timing	190CH	PCL19
		407	Switch_Spectrum -1800	190CH	PCL7		Rx	452	Rx Sensitivity	190CH	PCL7
		408	Switch_Spectrum -1200	190CH	PCL7			453	Rx Sensitivity	128CH	PCL7
		409	Switch_Spectrum -600	190CH	PCL7			454	Rx Sensitivity	251CH	PCL7
		410	Switch_Spectrum -400	190CH	PCL7			455	Usable Receiver Level	190CH	PCL7
		411	Switch_Spectrum +400	190CH	PCL7			456	Rx Level Reports	190CH	PCL7
		412	Switch_Spectrum +600	190CH	PCL7						
		413	Switch_Spectrum +1200	190CH	PCL7						
		414	Switch_Spectrum +1800	190CH	PCL7						
		415	Switch_Spectrum -1800	128CH	PCL7						

Troubleshooting list

Test item		Check parts for GSM900	Check parts for DCS	Check parts for PCS	Check parts for GSM850
Tx	Burst Power	IC802, FL803, FL905	IC802, FL803, FL905	IC802, FL803, FL905	IC802, FL803, FL905
	Frequency Error	TCX801	TCX801	TCX801	TCX801
	Phase Error	IC801	IC801	IC801	IC801
	Mod_spectrum	IC801, TCX801	IC801, TCX801	IC801, TCX801	IC801, TCX801
	Switch_Spectrum	IC801, IC802	IC801, IC802	IC801, IC802	IC801, IC802
	Burst Timing	IC802	IC802	IC802	IC802
Rx	Rx Sensitivity	IC801, FL803, FL902, FL904, FL905	IC801, FL803, FL902, FL905	IC801, FL803, FL903, FL905	IC801, FL803, FL901, FL904, FL905
	Usable Receiver Level	IC801	IC801	IC801	IC801
	Rx Level Reports	IC801, FL803, FL902, FL904, FL905	IC801, FL803, FL902, FL905	IC801, FL803, FL903, FL905	IC801, FL803, FL901, FL904, FL905

4.6. RF test tool**4.6.1 Requirements**

For repairs, this test checks the condition of an electric board (especially the RF section).

- PC with COM port
- GX30 Data Cable
- PWB repair jig
- GSM Tester (CMU200)

4.6.2 Setup

1. Set PWB and make connections as shown in Figures 56 and 57.
Make sure connections are correct at the points shown in Figure 58.

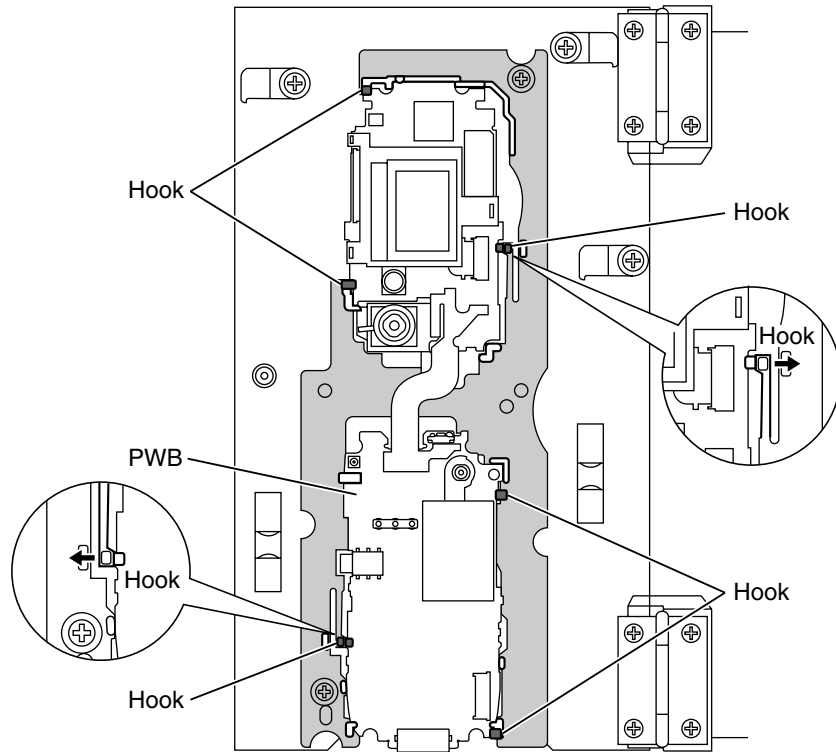

Figure 56 PWB installation

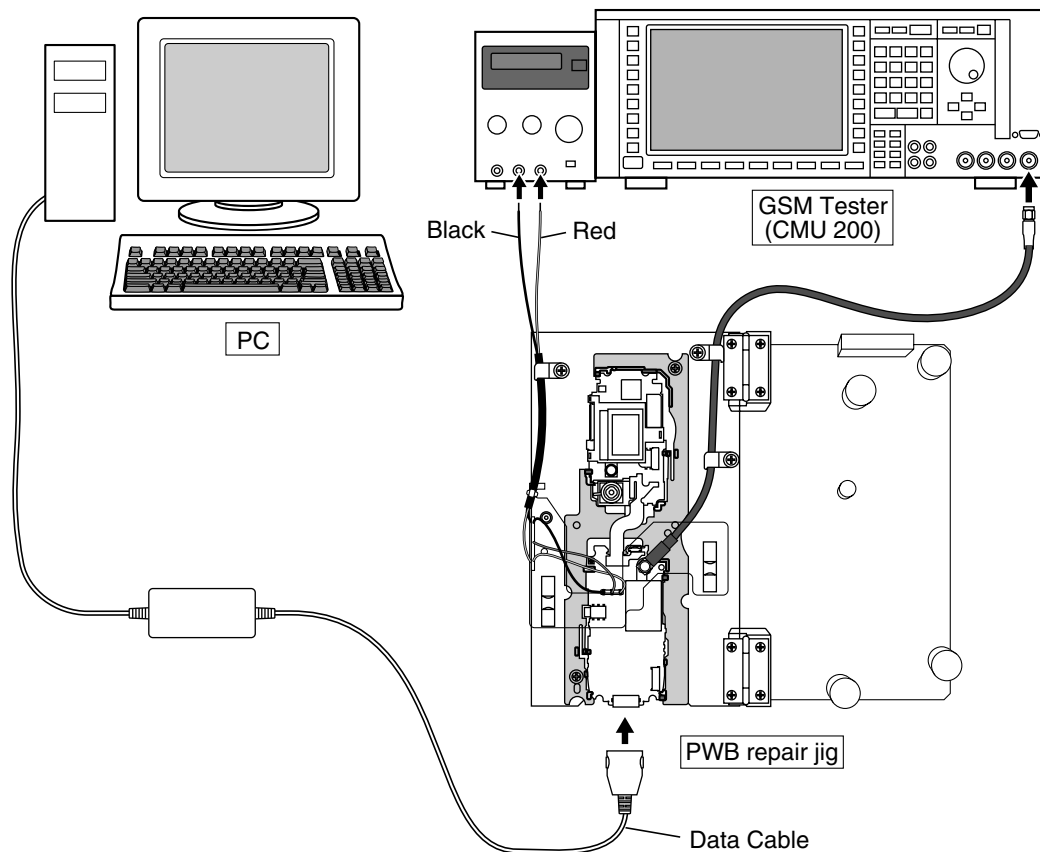

Figure 57 Connections

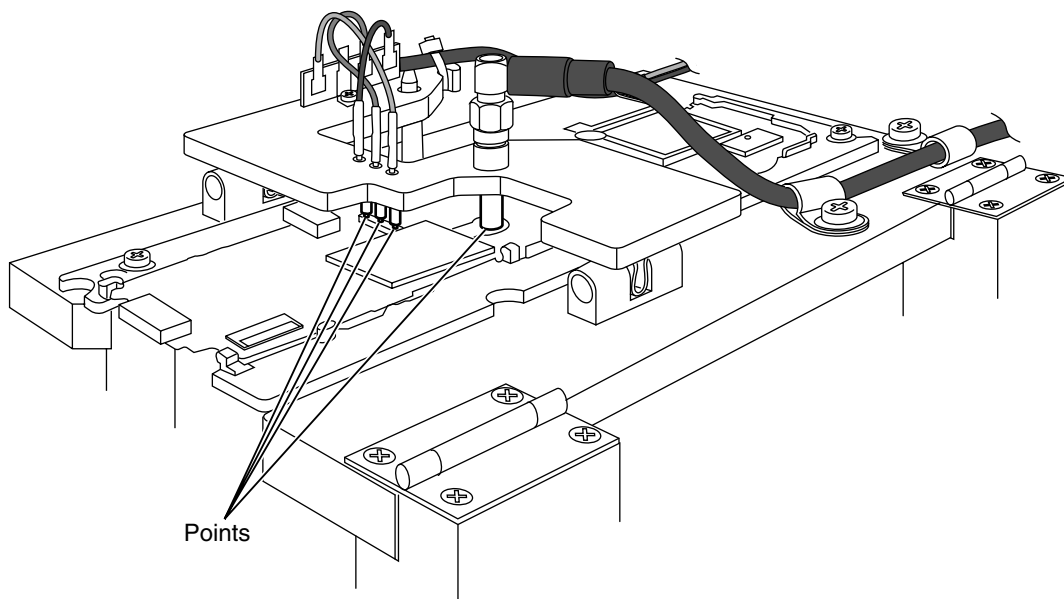

Figure 58 Contact points

2. Apply 4 V using a stabilized power supply and turn on the handset.

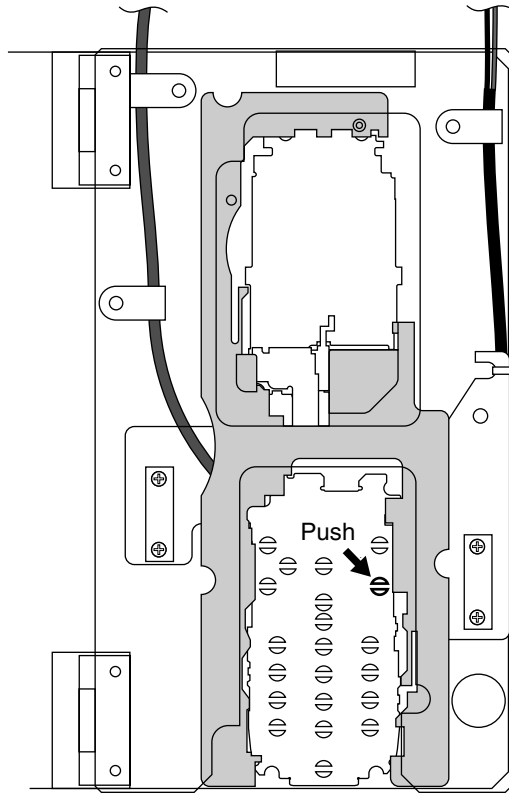

Figure 59 Turning power on

- 3. Start RF test tool.
- 4. Select a COM port to which Data Cable is connected. (Figure 60)
- 5. Press the "Initialize & Read Data" button. (Figure 60)

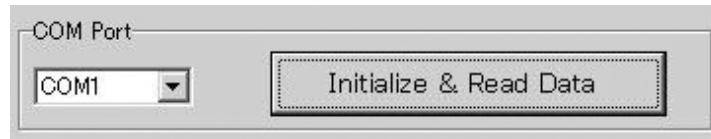

Figure 60

6. Figure 61 appears (wait a few seconds).



Figure 61

7. Click "OK" to proceed.

4.6.3 Tests

1) BAND Select & Channel

Select a band and a channel to test. Settings are applied to all tests.

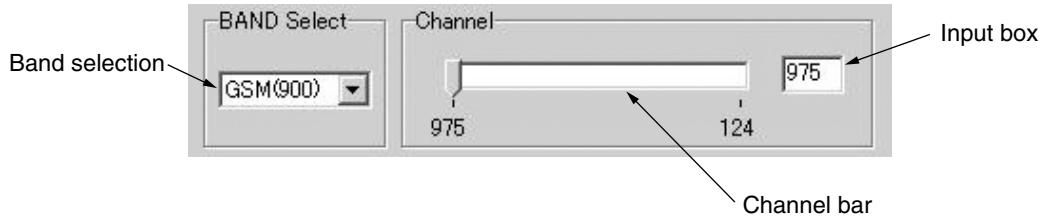

Figure 62

[Procedure]

1. Select a band. (GSM850, GSM900, DCS or PCS)
2. Select or enter a channel using Channel bar or Input box.

2) TX test

Test burst transmission.

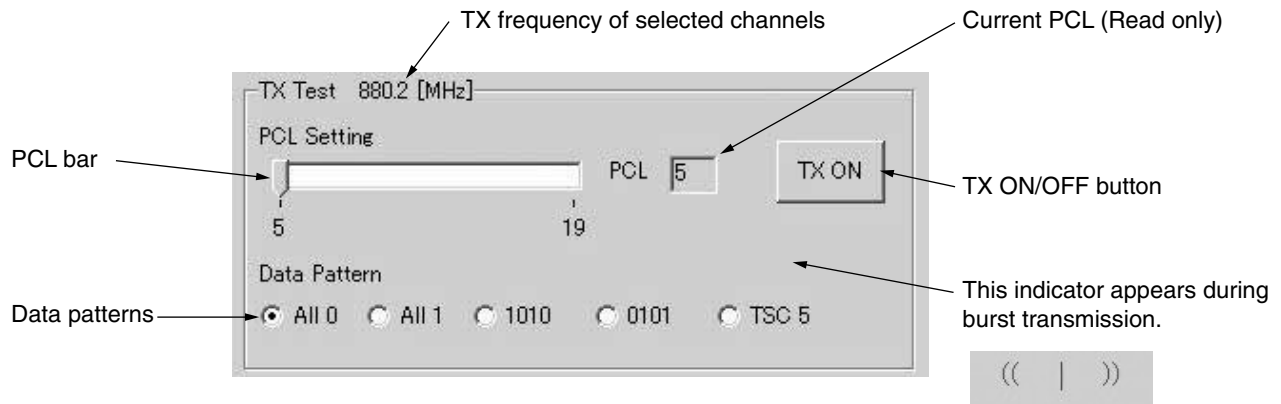

Figure 63

[Procedure]

1. Select a band and channel. [see 4.6.3.1]
2. Select PCL (Power Control Level) using PCL bar.
3. Select Data pattern.
4. Click TX ON to start burst transmission.
(You can check each part in this state.)
5. Click TX OFF to end burst transmission.

* Data pattern (TSC 5) includes Training Sequence GSM 5, and other part is pseudo random data.

GX30 TX power Table (25°C, voltage: 3.7[V])

GSM850 Band		
PCL	GSM850 [dBm]	Tolerance
7	29	+/-2 dB
8	27	+/-3 dB
9	25	+/-3 dB
10	23	+/-3 dB
11	21	+/-3 dB
12	19	+/-3 dB
13	17	+/-3 dB
14	15	+/-3 dB
15	13	+/-3 dB
16	11	+/-5 dB
17	9	+/-5 dB
18	7	+/-5 dB
19	5	+/-5 dB

GSM900 Band		
PCL	GSM900 [dBm]	Tolerance
5	33	+/-2 dB
6	31	+/-3 dB
7	29	+/-3 dB
8	27	+/-3 dB
9	25	+/-3 dB
10	23	+/-3 dB
11	21	+/-3 dB
12	19	+/-3 dB
13	17	+/-3 dB
14	15	+/-3 dB
15	13	+/-3 dB
16	11	+/-5 dB
17	9	+/-5 dB
18	7	+/-5 dB
19	5	+/-5 dB

DCS/PCS Band		
PCL	DCS/PCS [dBm]	Tolerance
0	30	+/-2 dB
1	28	+/-3 dB
2	26	+/-3 dB
3	24	+/-3 dB
4	22	+/-3 dB
5	20	+/-3 dB
6	18	+/-3 dB
7	16	+/-3 dB
8	14	+/-3 dB
9	12	+/-4 dB
10	10	+/-4 dB
11	8	+/-4 dB
12	6	+/-4 dB
13	4	+/-4 dB
14	2	+/-5 dB
15	0	+/-5 dB

3) RX test

The handset receives burst signals in this test.

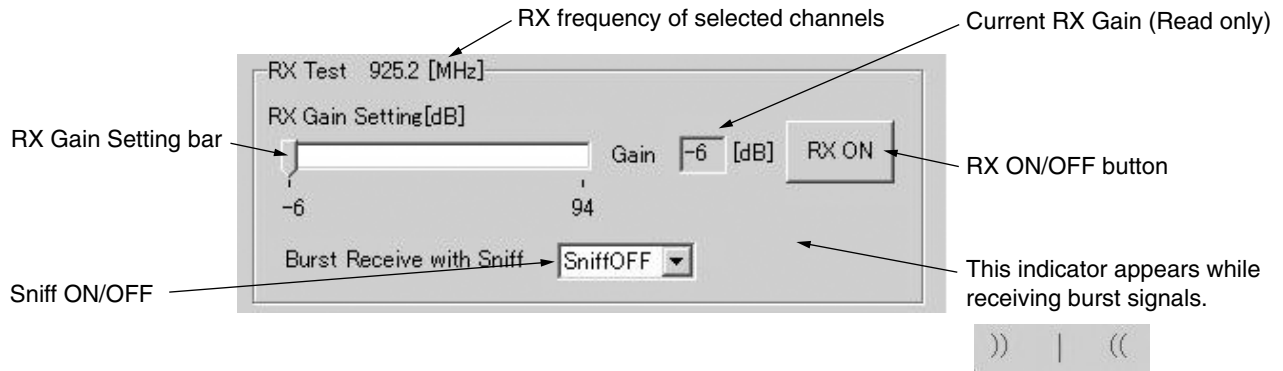

Figure 64

[Procedure]

1. Select a channel and band. [see 4.6.3.1]
2. Select RX Gain using RX Gain Setting bar.
3. Choose Sniff ON or OFF.
4. Click "RX ON" to start receiving burst signals.
5. From GSM tester, send burst signals in the specified channel.

(You can check each part in this state.)

6. Click "RX OFF" to end receiving burst signals.

* In this test, the reception timing cannot be synchronized with burst signals from Signal Generator or GSM tester.

* The standard RX Gain Setting is:
 (Input power at the aerial connector of the handset) + (RX Gain) = -16 dBm
 Excessive Input power or RX Gain may cause damage to the handset.

4) RSSI Measure

The handset notifies you of input power value at the aerial connector.

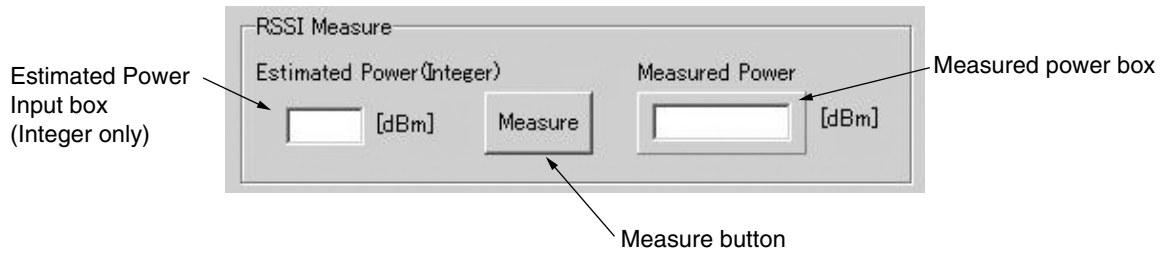

Figure 65

[Procedure]

1. Connect the handset and GSM tester (or Signal Generator) with RF cable.
2. Select a band and channel. [see 4.6.3.1]]
3. Send signals (*) from GSM tester.
4. Enter the value of input power from GSM tester in integers (from -10 to -110) considering RF cable loss.
5. Press the [Measure] button.
6. The result appears in Measured Power box.

* The signal type from GSM tester must be either of two:

1. Continuous sine wave (without modulation) with the frequency as follows:
 (Frequency of the measured channel) + 67.708kHz.
 (Ex. channel: GSM 37ch → the result: 942.467708 MHz)
 Power: -110 to -10 dBm
2. BCCH signal of the measured channel
 Power: -110 to -10 dBm

Result

When the handset is properly calibrated, the error between "Estimated Power" and "Measured Power" is less than 3dB.

4.6.4 Termination

Turn off the handset to ensure proper operations.

4.6.5 Trouble information

When switching DCS and PCS, change the channel number as well. Or the band does not change properly.

Example: If you change DCS 512 CH to PCS 512 CH, the band remains DCS.

4.7. Password reset

SPST resets the password (handset code is set to "0000").

<Operation>

1) Set the COM port on the SPST initial screen and click "User Password Reset". Click "Yes" to reset. Click "No" to exit.



Figure 66

2) When completed, the following appears.



Figure 67

4.8. Performance check and adjustment

With this function, SPST checks the performance of the handset and makes adjustments.

<Operation>

1) Set the COM port on the SPST initial screen and click “Performance check and adjustment”. The following dialog box appears while processing.



Figure 68

2) When completed, the following is displayed. Click “Back to main menu” to exit.

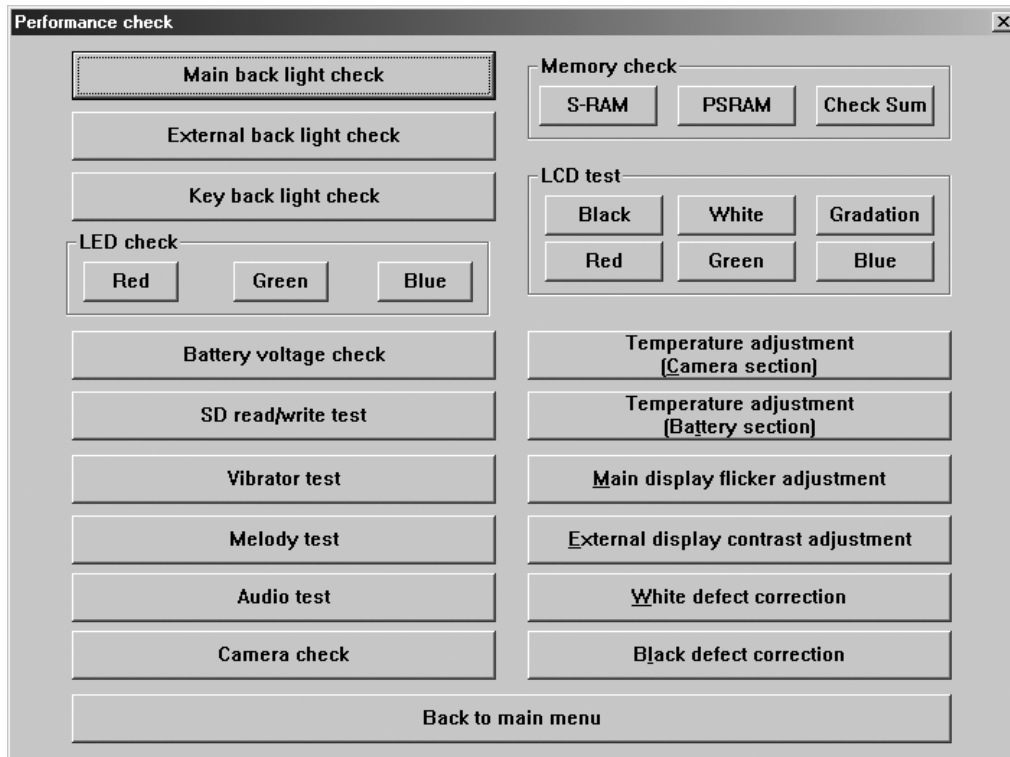

Figure 69

The functions of each button are described below.

4.8.1 Main back light check

The main display back light turns on and the message appears on the PC.



Figure 70

Check the back light and press “OK”.

- If a failure occurs, see “10. Back Light does not turn on.” in [3] Troubleshooting.

4.8.2 External back light check

The external display back light turns on and the message appears on the PC. Check the back light and press "OK".

- If a failure occurs, see "10. Back Light does not turn on." in [3] Troubleshooting.

4.8.3 Key back light check

The keypad back light turns on and the message appears on the PC. Check the back light and press "OK".

4.8.4 LED check

The LED lights up in a specified color and the message appears on the PC. Check the LED and press "OK".

- If a failure occurs, see "15. Flash light does not work." in [3] Troubleshooting.

4.8.5 Battery voltage check

Click to display the current battery voltage.

- If a failure occurs, see "1. Power is not turned on." in [3] Troubleshooting.

4.8.6 SD read/write test

Insert an SD card (otherwise a message prompts you to do so) and click the button to perform the SD card read/write test.

- If a failure occurs, see "17. SD (Memory) card is not recognized." in [3] Troubleshooting.

4.8.7 Vibrator test

Click to vibrate the handset. Click "OK" to exit.

- If a failure occurs, see "5. Vibrator does not work." in [3] Troubleshooting.

4.8.8 Melody test

A message describes test items. Click "Yes" to proceed and "No" to exit.

The order of the test items:

speaker → hands free → hands free (stereo) → speaker (analog melody)

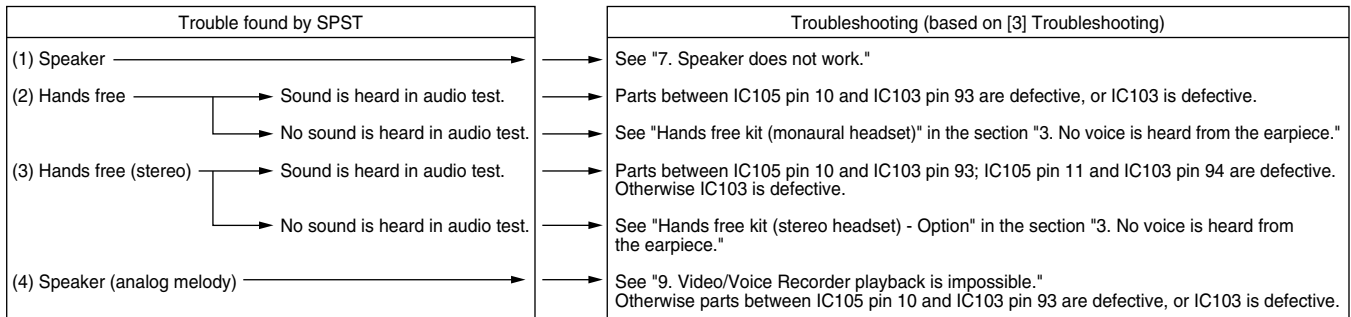

4.8.9 Audio test

The following appears.

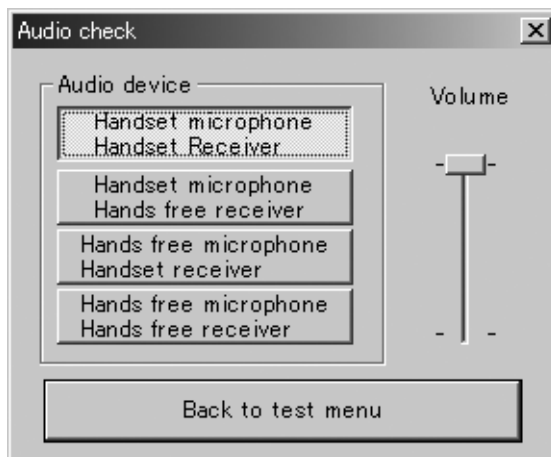
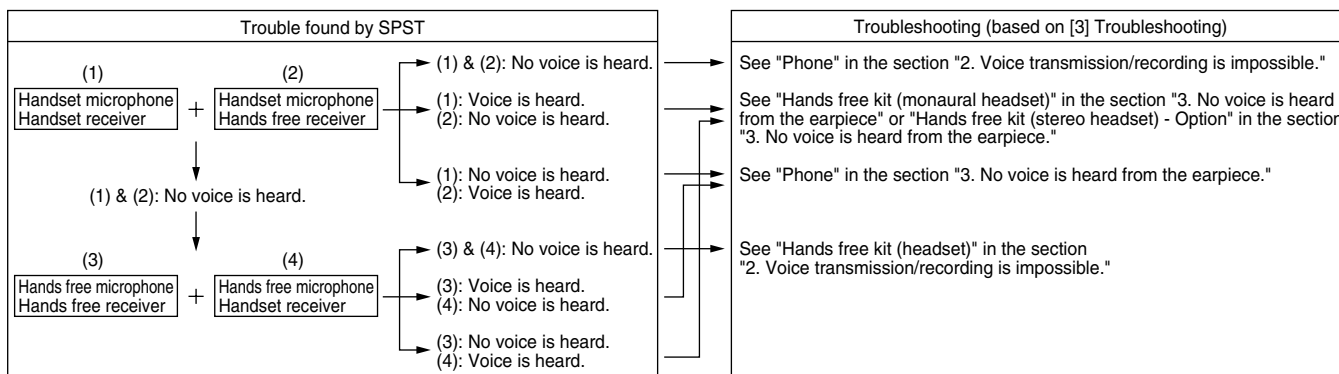

Figure 71

Select a test item from Audio device. Check the output sound from the receiver by speaking to the microphone, etc. Click "Back to test menu" to return to the previous screen.



4.8.10 Camera check

The following appears.

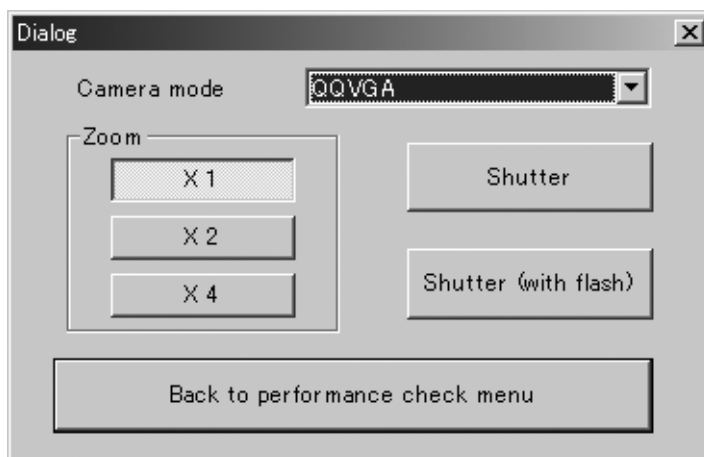

Figure 72

Select a Camera mode from the pull-down menu. Click "Shutter" to check that the camera operates properly. Click "Back to performance check menu" to return to the previous screen.

- If a failure occurs, see "14. Pictures cannot be taken." in [3] Troubleshooting.

4.8.11 Memory check

Click "S-RAM" and "PSRAM" to see each test result.
For "Check Sum", the calculation appears after the SPST communicating dialog box.

4.8.12 LCD test

Check that the specified color appears on the main display.

- If a failure occurs, see “12. The display does not appear on Main Display.” and “13. The display does not appear on External Display (in 65K color mode).” in [3] Troubleshooting.

4.8.13 Temperature adjustment

The following appears.

Setting temp. indicates the current temperature. The relative temperature is displayed in the text box below. (Only the relative temperature is adjustable.)

If displayed Setting temp. value differs from the current temperature, click “ ▲ ” or “ ▼ ” to set a correction value in the range of –99 to +99 and click “Save”.

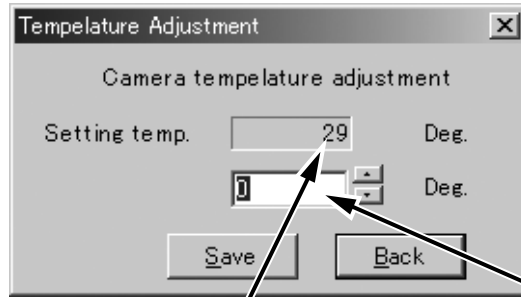

$$\text{Correction value} = (\text{Setting temp.}) - (\text{current temp.}) + (\text{displayed correction value})$$

Figure 73

4.8.14 Main display flicker adjustment

The following is displayed.

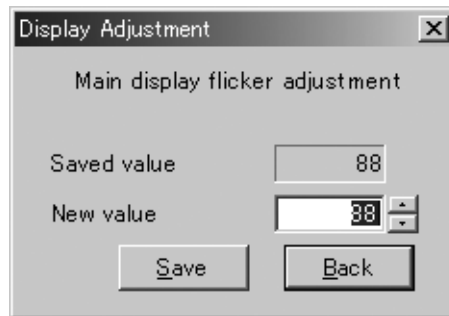
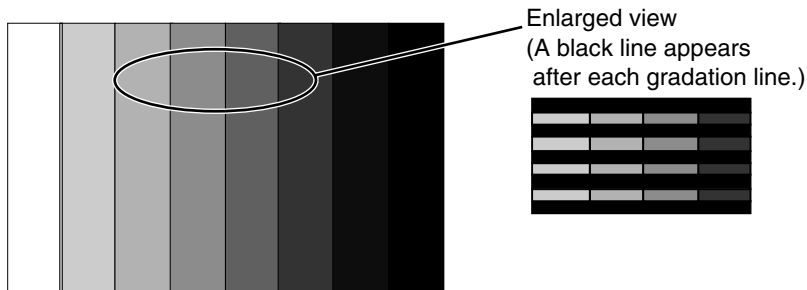

Figure 74

Check a main display visually within a distance of 20 cm from a fluorescent light, and adjust the value to minimize flicker on the display with the “ ▲ ” and “ ▼ ” buttons. Click “Save” and confirm that the main display does not flicker.

(Fine adjustment for DC voltage between display electrodes)



8-level gradation pattern with alternate black and gradation lines (black and white)

Figure 75

4.8.15 External display contrast adjustment

Click the "External display contrast adjustment" button. The following screen appears.

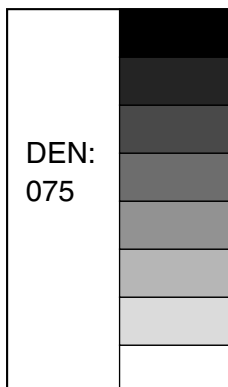
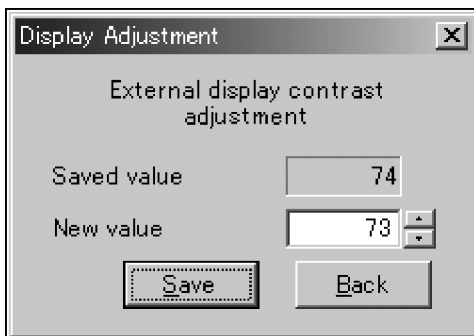

8-level gradation pattern (black & white pattern)

Figure 76

Comparing with an adjusted handset, click "▲" or "▼" to adjust the value so that the same gradation pattern is displayed. Click "Save" and confirm the pattern on the external display.

4.8.16 White defect correction

* White defect correction:

Defective pixels in a camera light sensor appear as bright points in the display even when light is blocked completely (display is all black). Perform white defect correction to eliminate errors in these pixels.

1. Protect the handset camera from light completely with a black cover.
2. Click the "White defect correction" button. The following screen appears.

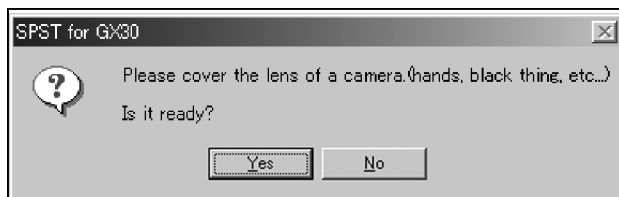

Figure 77

Click the "Yes" button and leave it for about 20 seconds. When completed, the following message appears.

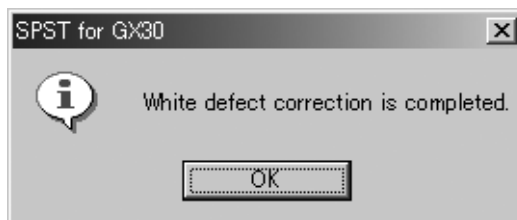

Figure 78

When an error occurs, the corresponding message appears. Solve the problem according to "Solution".

- Error 1
Error message: "There are too many white cracks."
Cause: The light is not sufficiently blocked.
Solution: Block the light completely and perform white defect correction again.
- Error 2
Error message: "There are many white cracks."
Cause: The light is not sufficiently blocked.
Solution: Block the light completely and perform white defect correction again.
- Error 3
Error message: "There are too many white cracks cannot be rectified."
Cause: There is a hardware error.
Solution: Replace the camera unit.

4.8.17 Black defect correction

*Black defect correction:

Defective pixels in a camera light sensor appear as black points in the display even when a captured image is completely white (display is all white). Perform black defect correction to eliminate errors in these pixels.

1) Requirements

- Desk top type of fluorescent lamp
- Black defect correction sheet

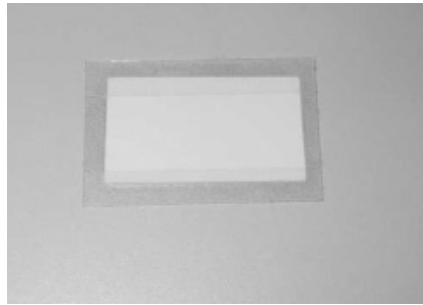

Figure 79

- Illuminance meter

2) Procedure

1. Cover the camera section with the black defect correction sheet as shown in Figure 80.

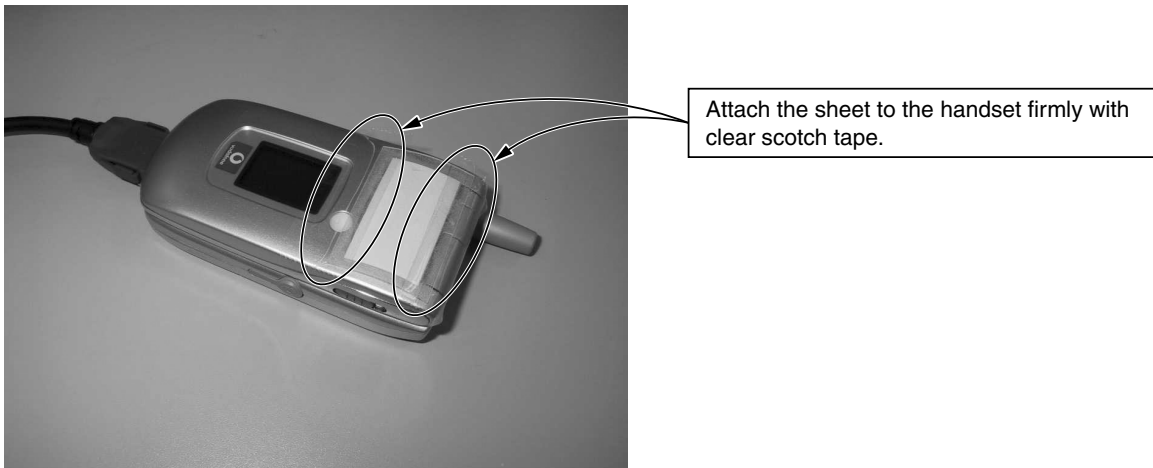

Figure 80

- 2. Check the distance from the fluorescent lamp by using an illuminance meter.
In the proper position for black defect correction, illuminance is between 8,000 and 10,000 lux.



Figure 81

- 3. Hold the handset in the proper position.



Figure 82

- 4. Click the "Black defect correction" button.
The following message is displayed.

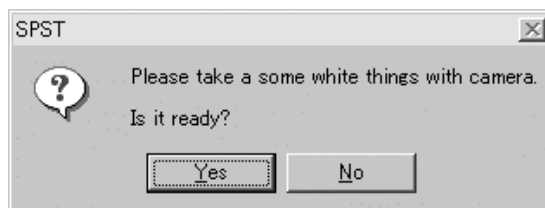

Figure 83

- 5. Click the "Yes" button. Communication starts.



Figure 84

6. The result is displayed within a minute as follows.

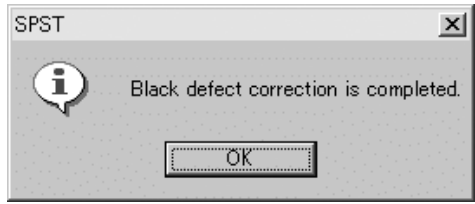

Figure 85

When an error occurs, the corresponding message appears. Solve the problem according to "Solution".

- Error 1
 Error message: "There are too many black cracks."
 Cause: The light is too weak or strong.
 Solution: At the proper distance from the light source (8,000 - 10,000 lux), perform black defect correction again.
- Error 2
 Error message: "There are many black cracks."
 Cause: The light is too weak or strong.
 Solution: At the proper distance from the light source (8,000 - 10,000 lux), perform black defect correction again.
- Error 3
 Error message: "There are too many black cracks cannot be rectified."
 Cause: There is a hardware error.
 Solution: Replace the camera unit.

4.9. **mode release**

When the handset does not turn on and enter the normal mode, use this function to change ****mode to the normal mode.

<Operation>

1) Select the COM port on the SPST initial screen and click "****mode release". The following dialog box appears.



Figure 86

2) If SPST cannot communicate with the handset, the following message is displayed. Make sure the handset is turned on and click "Retry". To exit, click "Cancel".



Figure 87

3) When complete, the following message appears.



Figure 88

5. Other tests

SPST does not provide tests of Bluetooth/USB communication. Check them according to the following instructions.

5.1. Bluetooth

Connect GX30 to the network and check that a conversation (talking and listening) is possible using a Bluetooth headset.

Recommended Bluetooth headset:

JABRA BT200

PLANTRONICS M1000

PLANTRONICS M3000

5.2. USB

Connect GX30 and a PC with a USB cable. Check that GX30 is recognized as a device.

If the USB driver for GX30 (SHARP GSM GPRS USB Driver) is not installed on the PC, "Found New Hardware" window appears and "Found New Hardware Wizard" starts (the handset is recognized).

[2] Test points

MAIN PWB-A (FRONT SIDE)

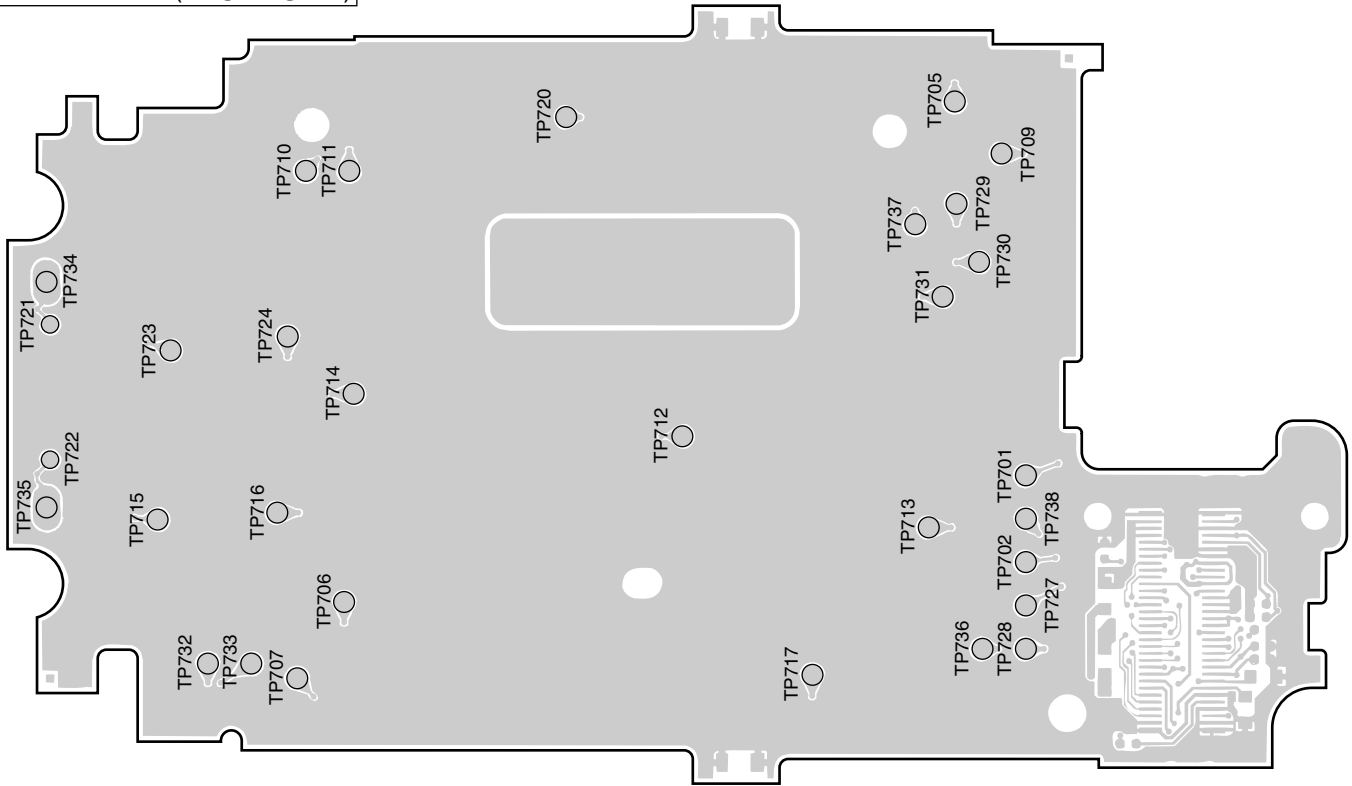

Figure 89 TEST POINT

TP No.	Signal name	TP No.	Signal name
TP701	SP1	TP722	RECIVER_OUTP
TP702	SP2	TP723	Terminal for LCDC adhesion check 3
TP705	VCCD (2.5V)	TP724	Terminal for LCDC adhesion check 4
TP706	Terminal for APPLICATION POWER adhesion check 1	TP727	LIGHT1
TP707	Terminal for APPLICATION POWER adhesion check 2	TP728	LEDCTL
TP709	VDD6 (3.1V)	TP729	LEDR
TP710	Backlight (LED+)	TP730	LEDG
TP711	Backlight (LED-)	TP731	LEDB
TP712	CAMCLK	TP732	Power supply for camera (+15V)
TP713	13MHzCLK	TP733	Power supply for camera (-8V)
TP714	VLCD (1.8V)	TP734	RECIVER_OUTN
TP715	Terminal for LCDC adhesion check 1	TP735	RECIVER_OUTP
TP716	Terminal for LCDC adhesion check 2	TP736	AVDD (3.1V)
TP717	VOOUT (External Display)	TP737	VPLUS2
TP720	VDD2	TP738	Connector connection check terminal
TP721	RECIVER_OUTN		

MAIN PWB-A (REAR SIDE)

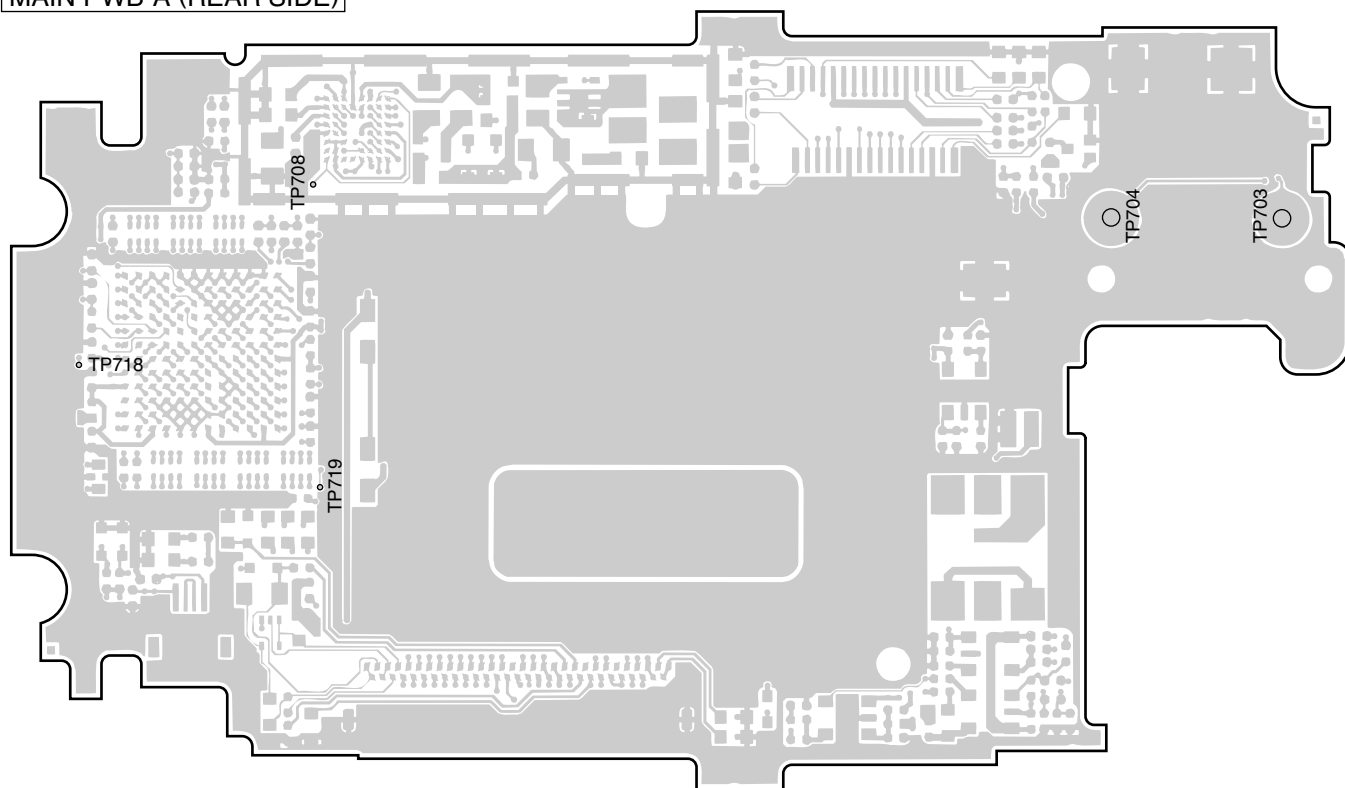

Figure 90 TEST POINT

TP No.	Signal name	TP No.	Signal name
TP703	SP1	TP704	SP2

KEY PWB-B (FRONT SIDE)

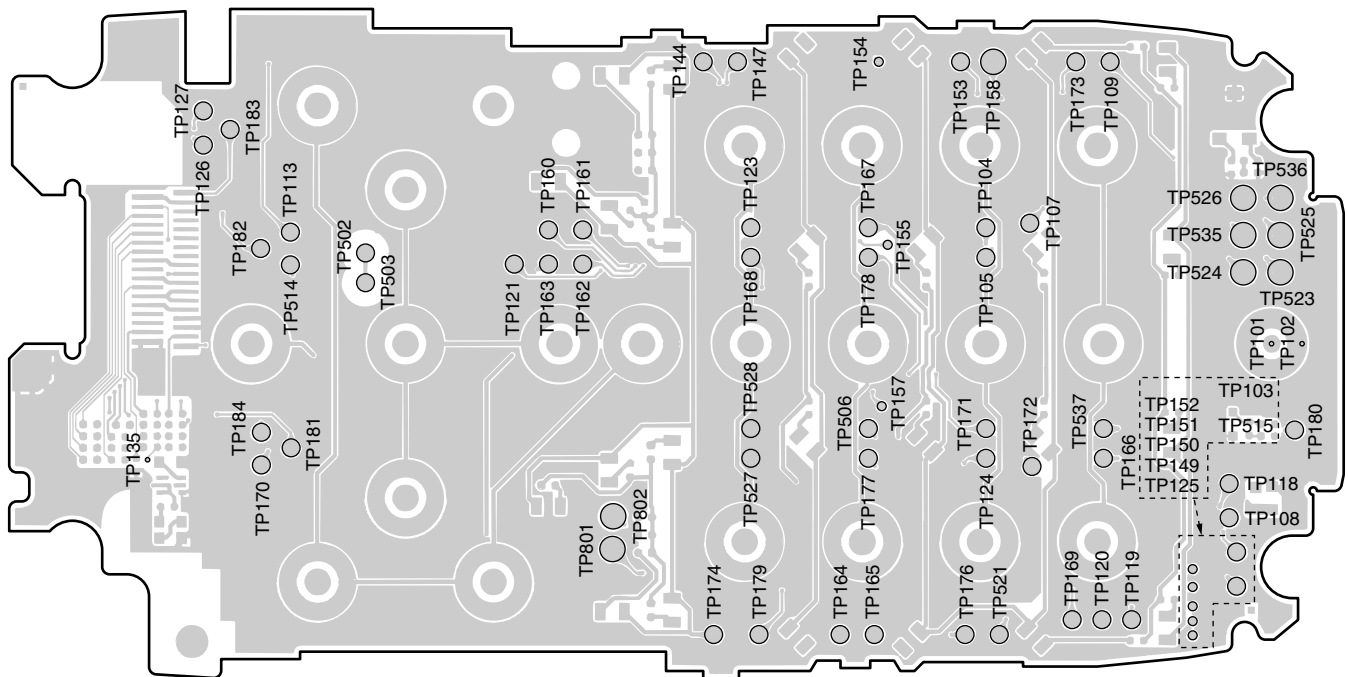

Figure 91 TEST POINT

TP No.	Signal name	TP No.	Signal name
TP103	USC [0]	TP171	VCORE (1.8V)
TP104	USC [1]	TP172	VAPP
TP105	USC [2]	TP173	VINT (3V)
TP107	USC [4]	TP174	LIGHT3 (KEYLED)
TP108	USC [5]	TP176	VMIC
TP109	USC [6]	TP177	AUXADC1, 2
TP113	VVIB	TP178	TEMP
TP118	USC [3]	TP179	AUXADC1, 2
TP119	MIC	TP180	CHGIN_A (5.2V)
TP120	AUDIO_IN	TP181	Flexible PWB insert check terminal 1
TP121	JACK_L	TP182	Flexible PWB insert check terminal 2
TP123	RESET	TP183	Flexible PWB insert check terminal 3
TP124	PWRON	TP184	Flexible PWB insert check terminal 4
TP126	SP1	TP502	VBAT
TP127	SP2	TP503	VBAT
TP144	Terminal for STACK MEMORY adhesion check 1	TP506	BATT_SENSE
TP147	Terminal for STACK MEMORY adhesion check 2	TP514	BT_VCC (3.0V)
TP153	VPP Flash	TP515	VBUS_IN
TP157	Analog Power Supply IC INT	TP521	POWONKEY
TP158	VINT (3V)	TP523	USB D+
TP160	HEDSET_DET	TP524	USB D-
TP161	STEREO_SW	TP525	RTS
TP162	REMOTE_SW	TP526	CTS
TP163	JACK_R	TP527	DGND
TP164	VABB	TP528	DGND
TP165	VT (2.75V)	TP535	Reserved
TP166	VUSB	TP536	ManufactUre Specific
TP167	VRTC (1.8V)	TP537	CHGIN
TP168	VBACK (3V)	TP801	VTCXO (2.9V)
TP169	VSIM (2.85V)	TP802	VRF (2.9V)
TP170	VMEM (2.8V)		

KEY PWB-B (REAR SIDE)

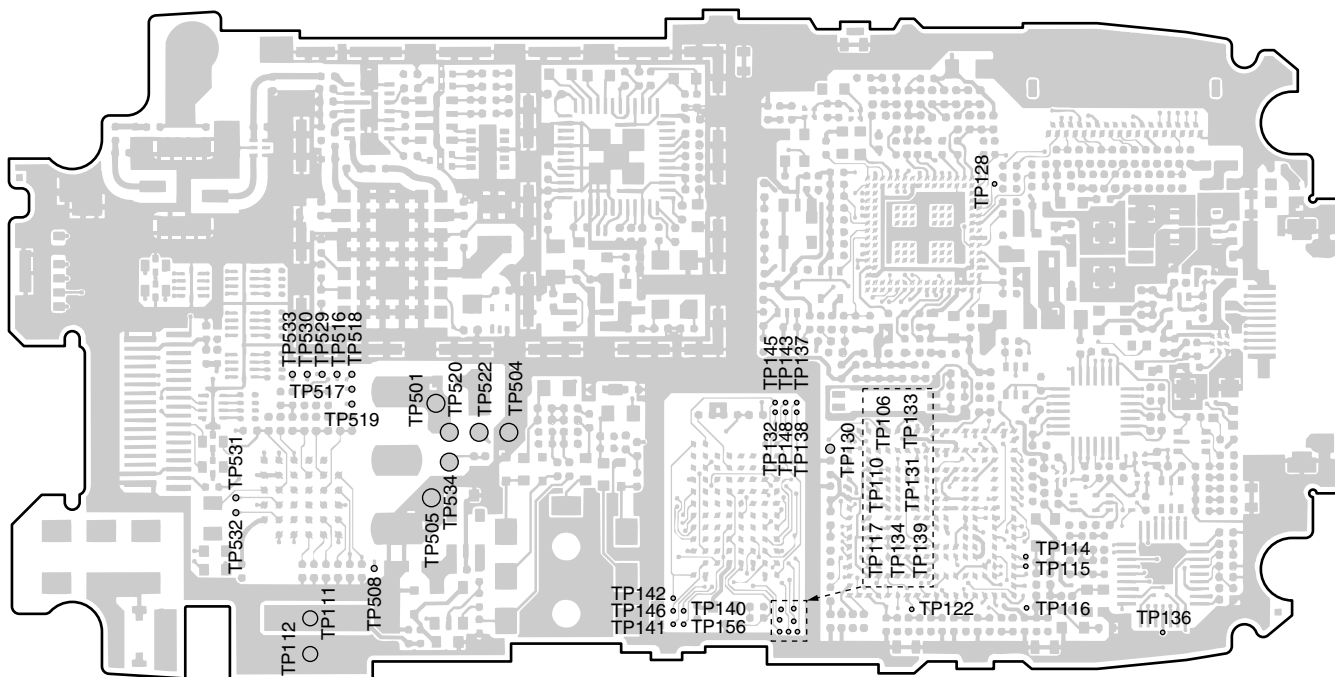

Figure 92 TEST POINT

TP No.	Signal name	TP No.	Signal name
TP111	VVIB	TP505	DGND
TP112	DGND	TP520	BATT
TP501	BATT	TP522	POWONKEY
TP504	DGND	TP534	BATT_SENSE

[3] Troubleshooting

1. Power is not turned on.	See page 2-48
2. Voice transmission/recording is impossible.	See page 2-50
3. No voice is heard from the earpiece.	See page 2-52
4. Battery does not charge.	See page 2-54
5. Vibrator does not work.	See page 2-54
6. Clock Settings are reset.	See page 2-55
7. Speaker does not work.	See page 2-55
8. MP3 cannot be played.	See page 2-56
9. Video/Voice Recorder playback is impossible.	See page 2-57
10. Back Light does not turn on.	See page 2-58
11. Out of range and incoming/outgoing calls are impossible.	See page 2-59
12. The display does not appear on Main Display.	See page 2-60
13. The display does not appear on External Display (in 65K color mode).	See page 2-61
14. Pictures cannot be taken.	See page 2-62
15. Flash light does not work.	See page 2-63
16. SIM card is not recognized.	See page 2-64
17. SD (Memory) card is not recognized.	See page 2-65
18. IrDA (Infrared) communication is not possible.	See page 2-66
19. Bluetooth communication is impossible.	See page 2-67
20. USB connection is impossible.	See page 2-68

1. Power is not turned on.

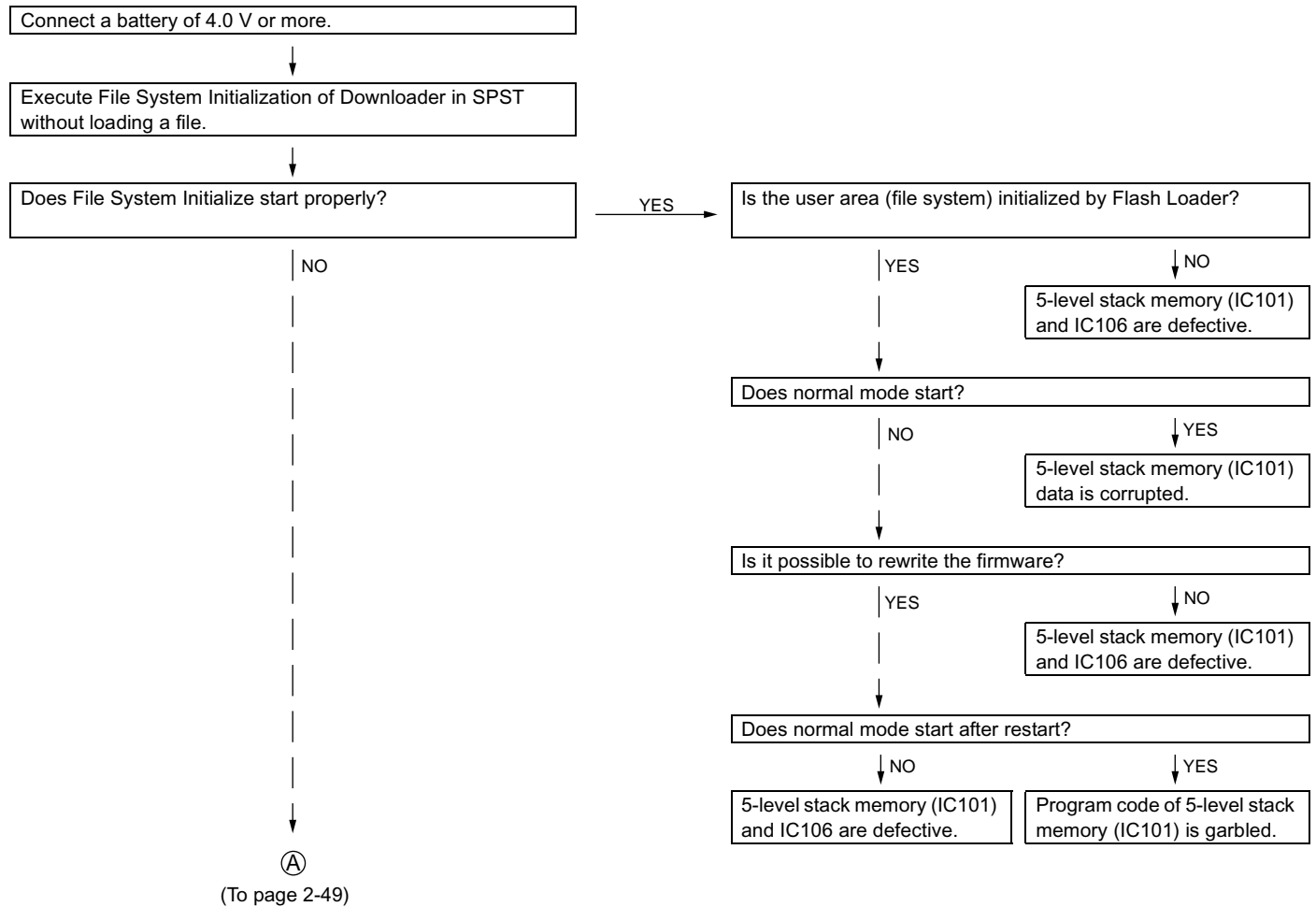

(From page 2-48)

Ⓐ

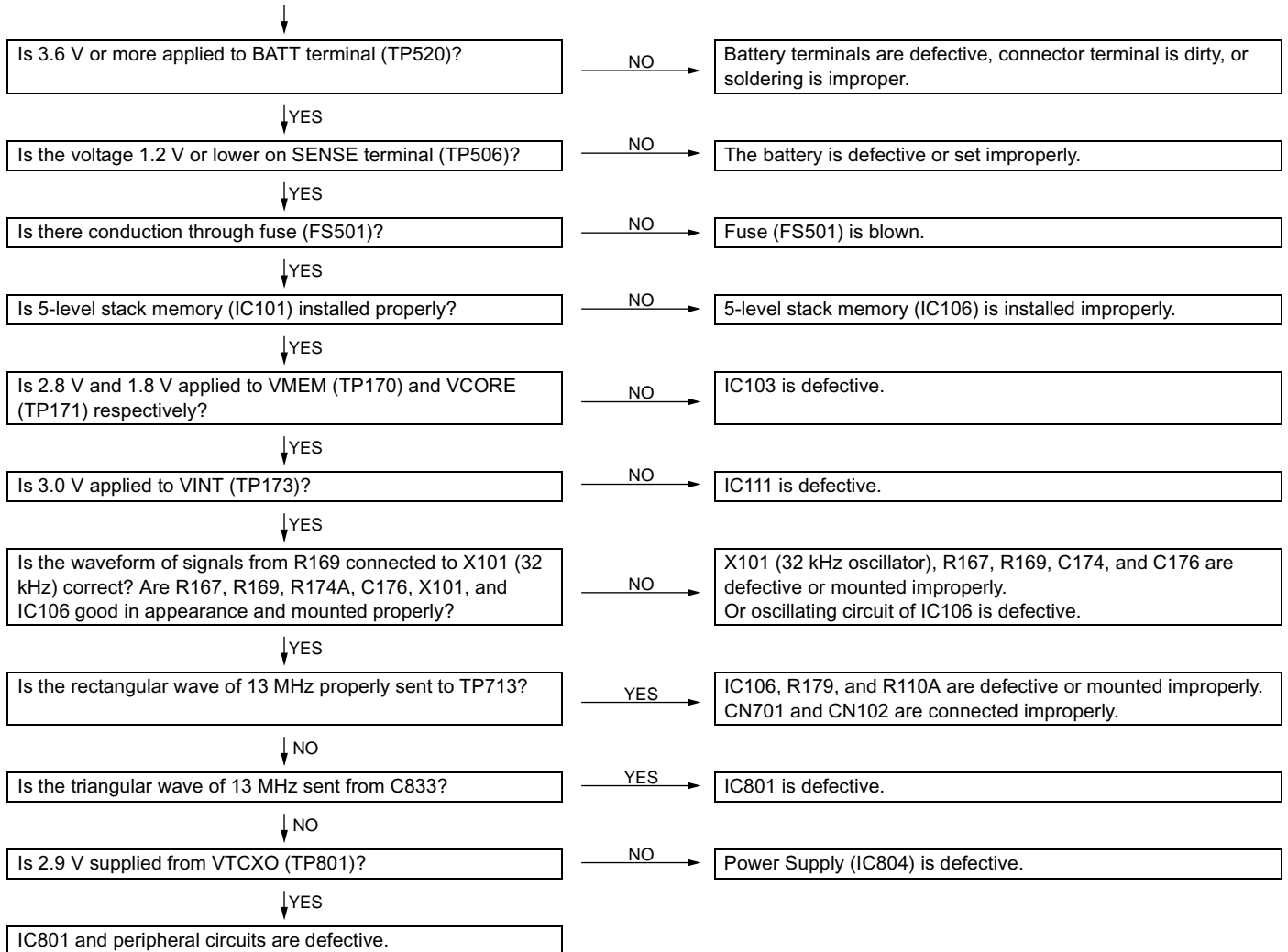

2. Voice transmission/recording is impossible.

Phone (Handset)

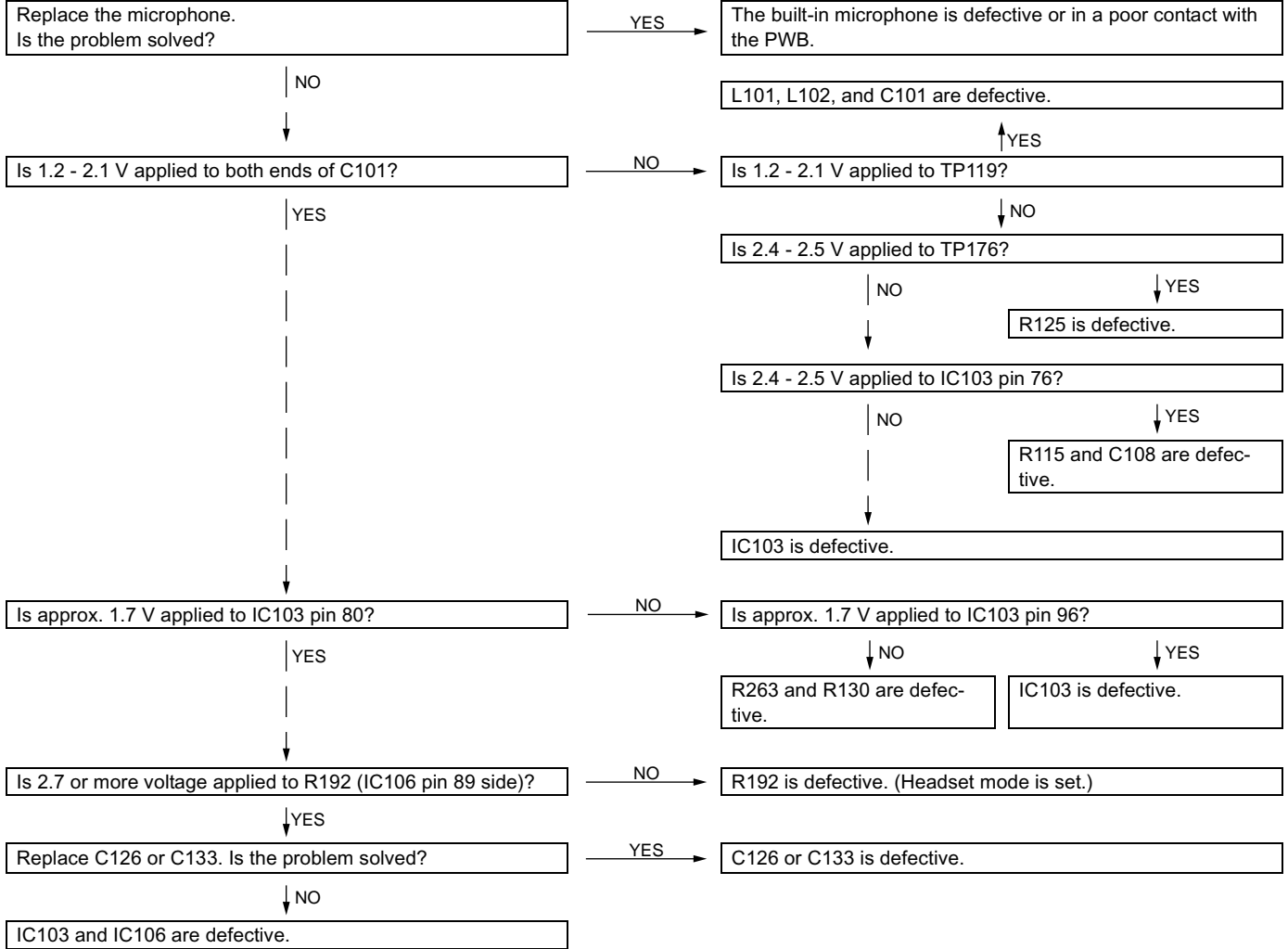

Hands free kit (Headset)

(The following procedure applies to both monaural and stereo headsets.)

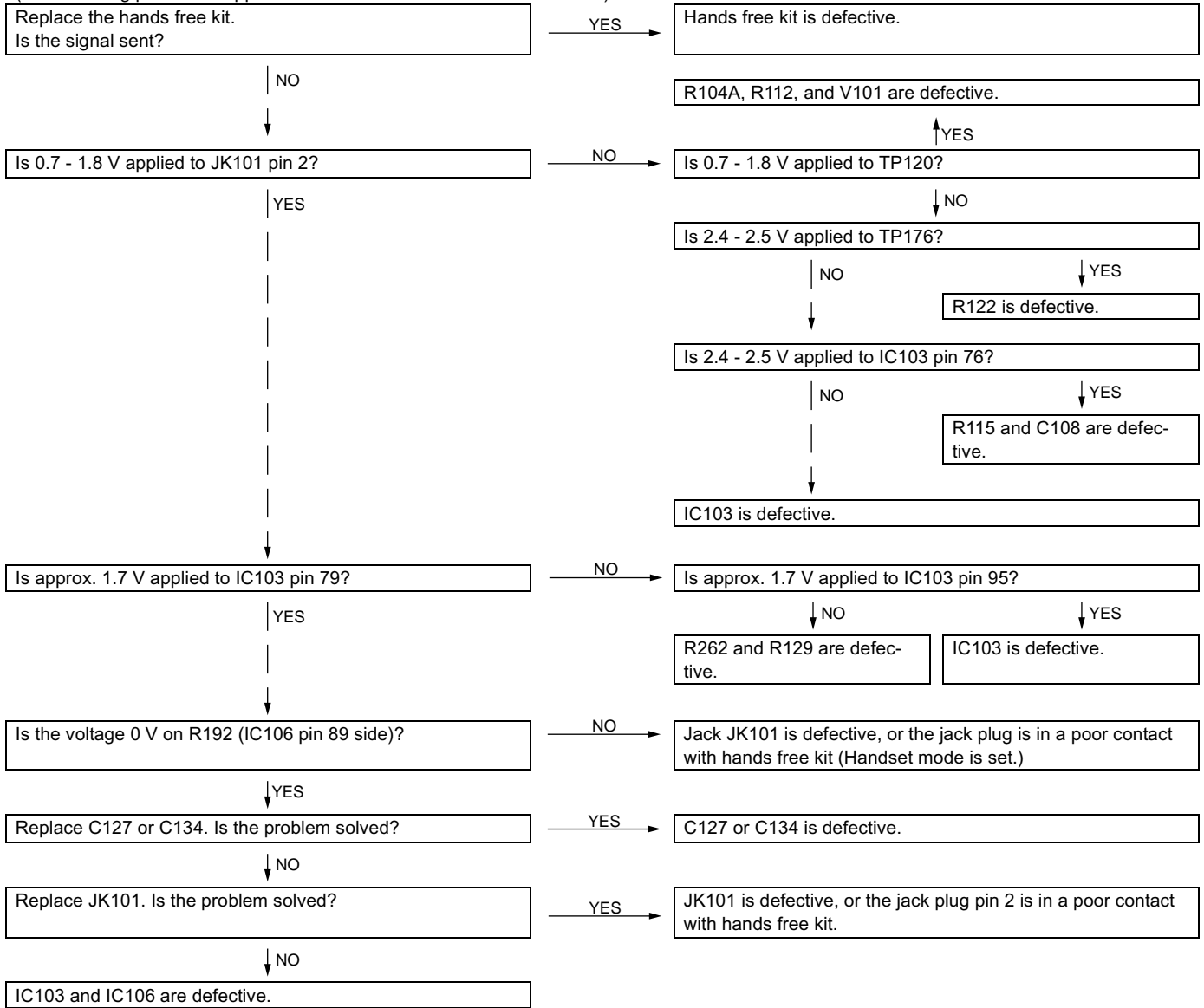

3. No voice is heard from the earpiece.

Phone (Handset)

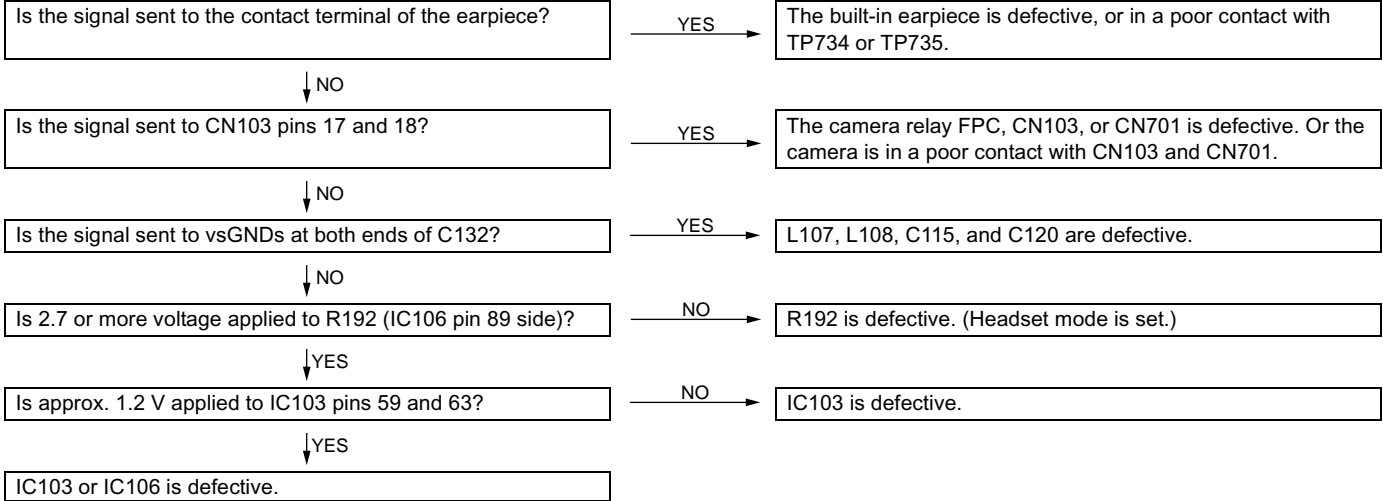

Hands free kit (monaural headset)

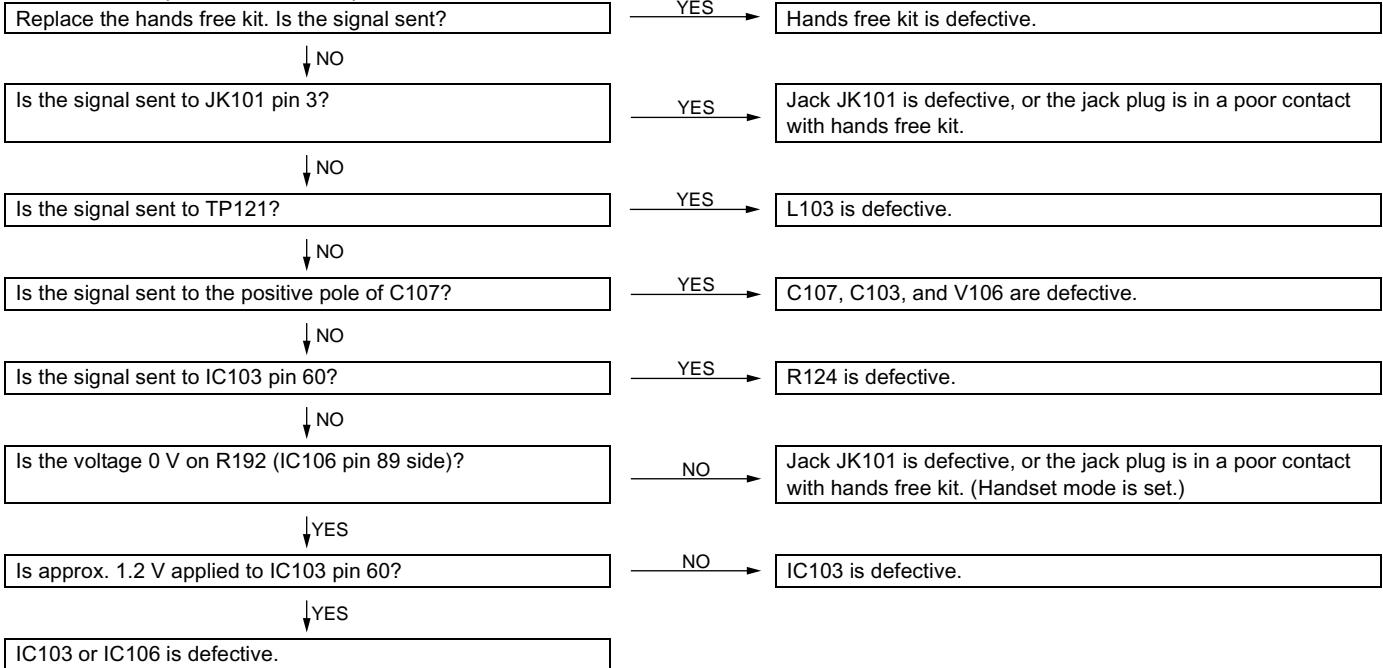

Hands free kit (stereo headset) - Option

The headset cannot be used. (It works as a monaural headset.)

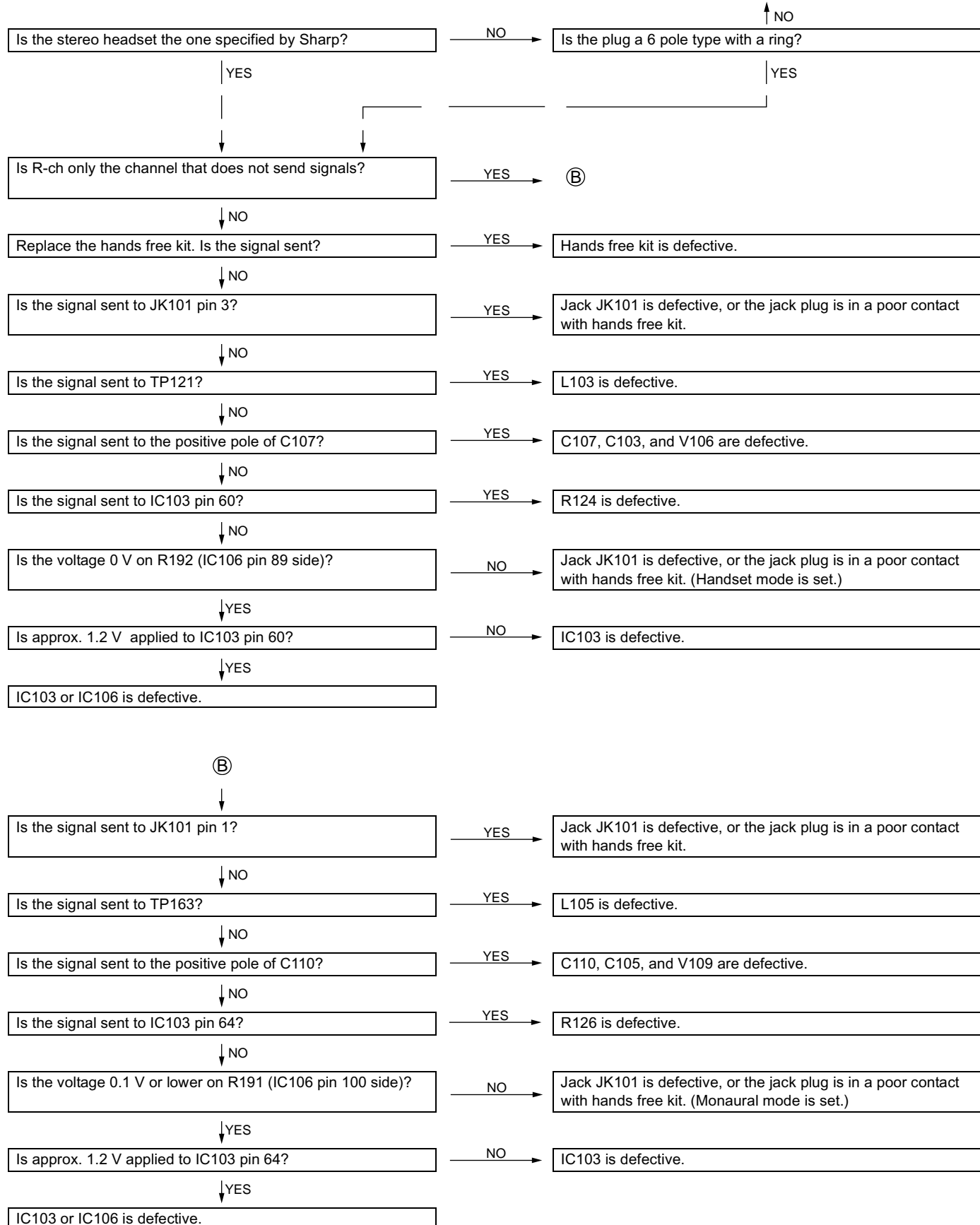

4. Battery does not charge.

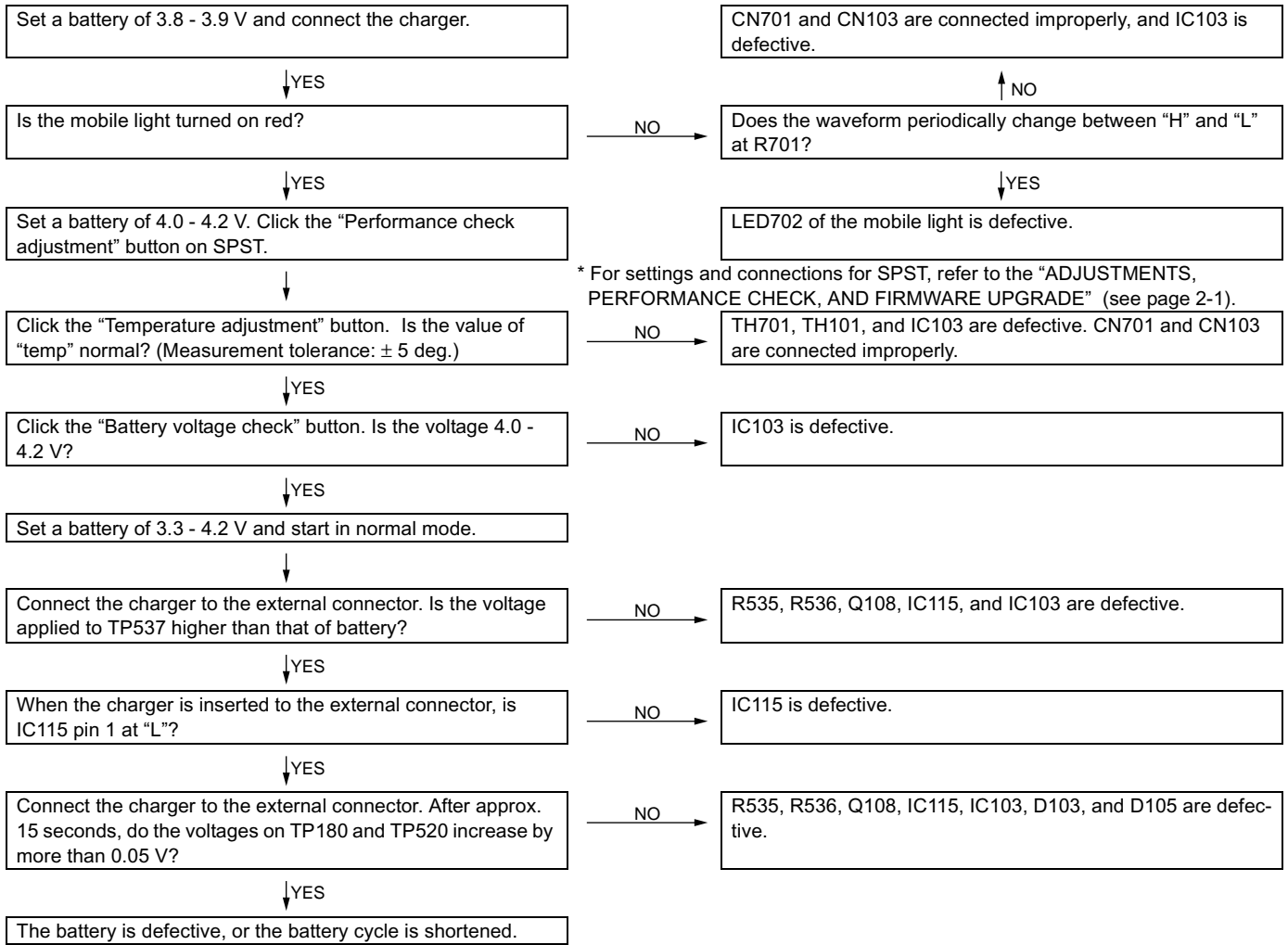

5. Vibrator does not work.

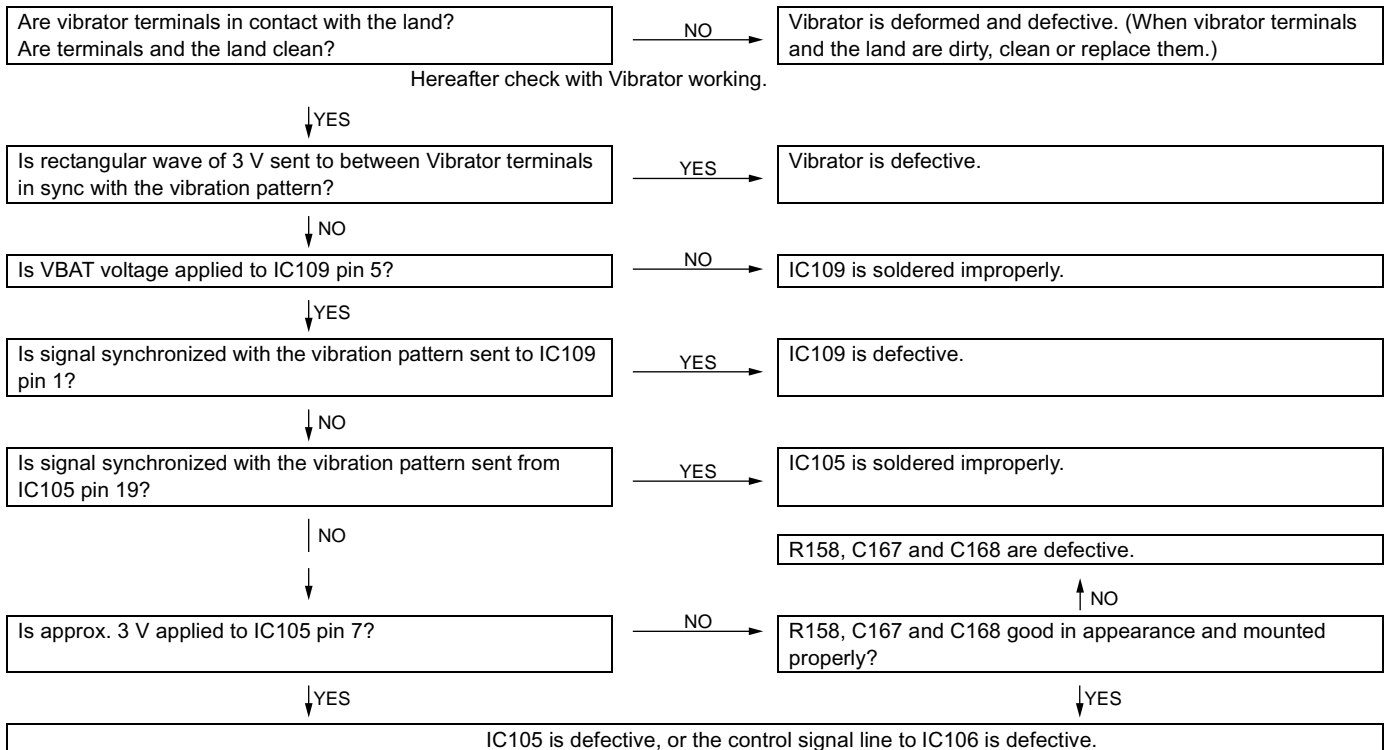

6. Clock Settings are reset.

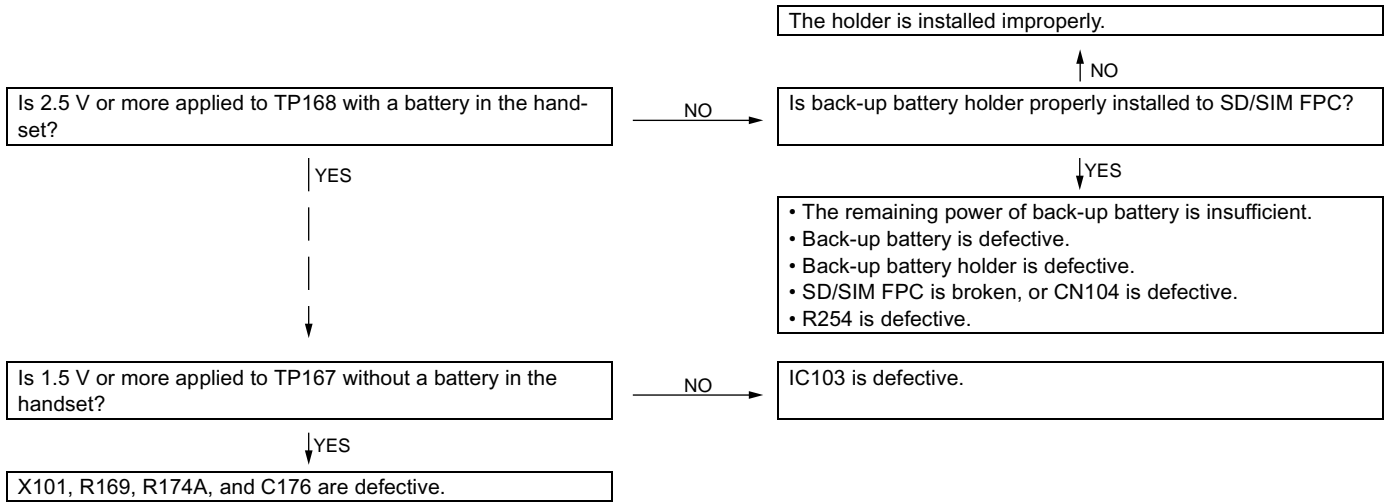

7. Speaker does not work.

- * When ring tones sound, but keypad tones do not, "Keypad Tones" is set to Off.
- * When Ringer Volume is set to "Silent":
 - Voice Recorder playback sound is not produced.
 - Playback sound of Video and MP3 can be heard by increasing the volume during playback.

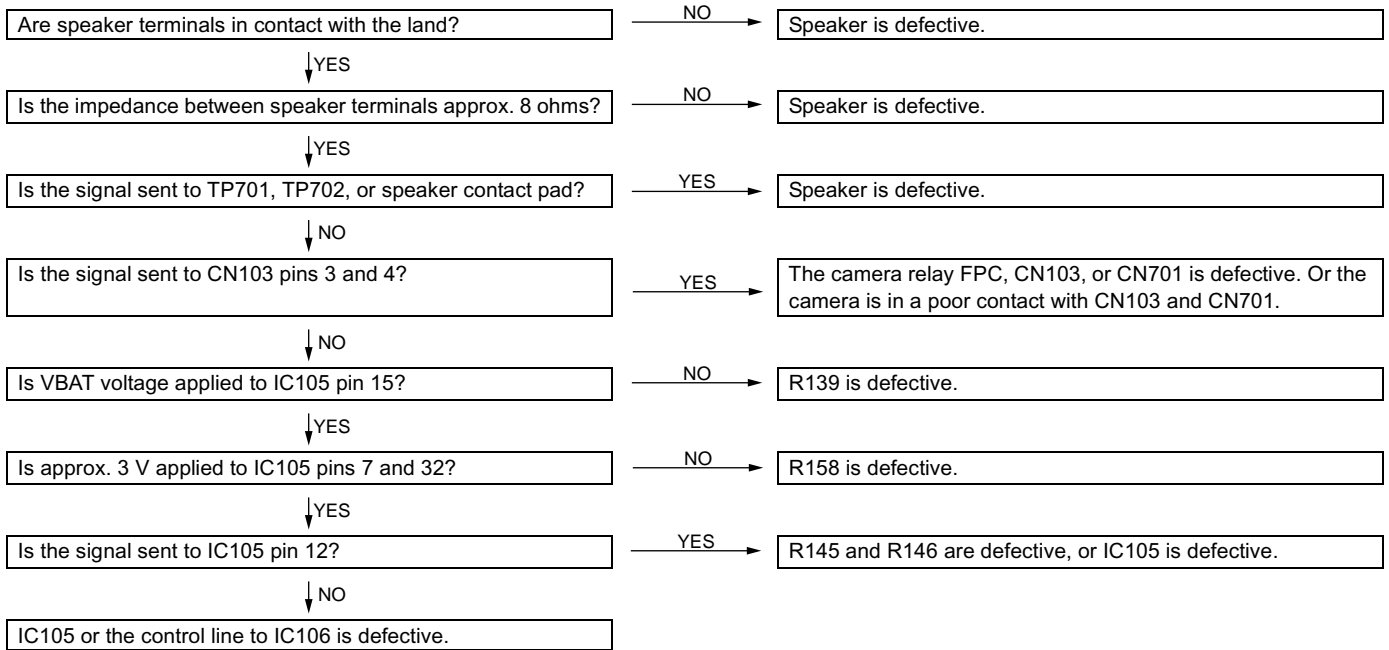

8. MP3 cannot be played.

Speaker

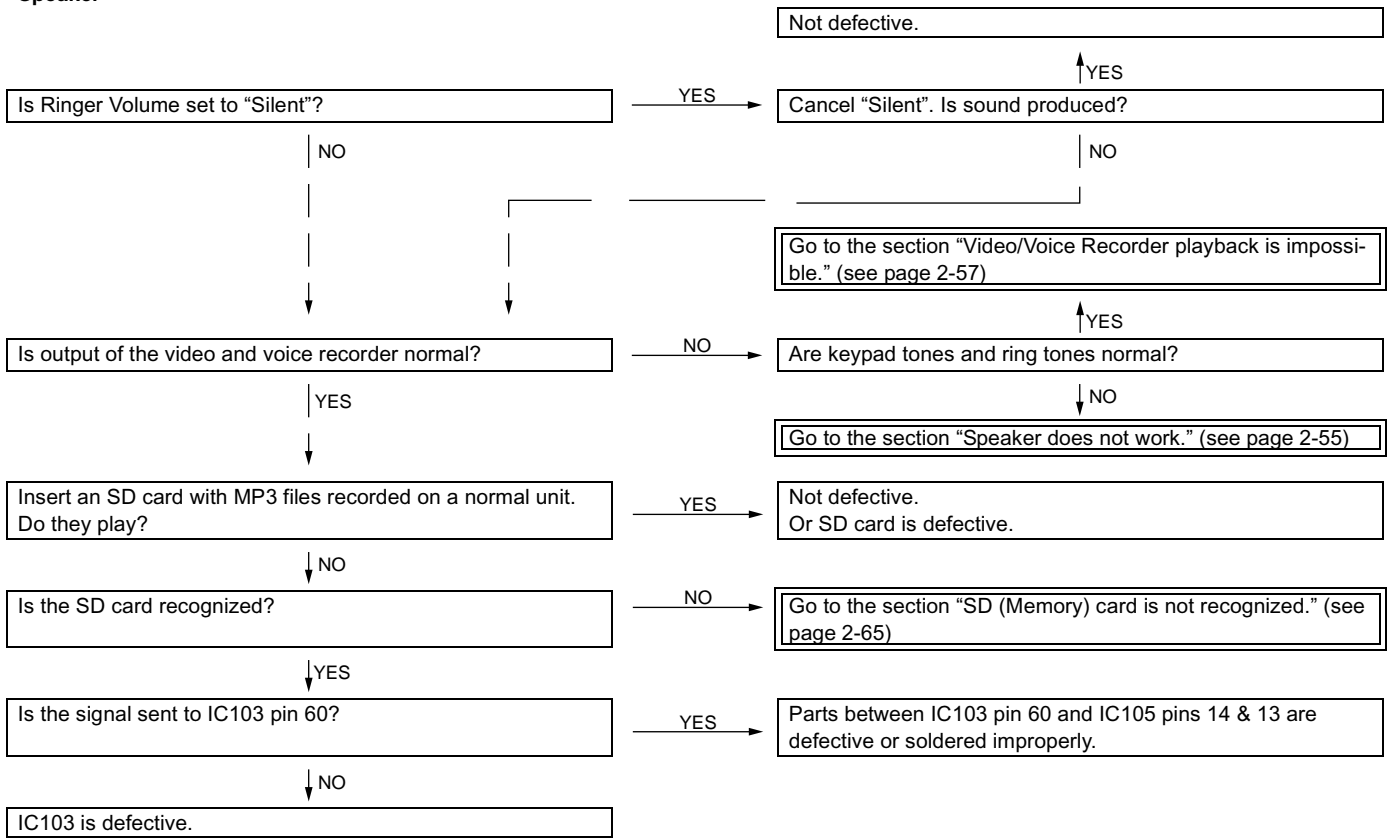

Hands free kit (headset)

(The following procedure applies to both monaural and stereo headsets.)

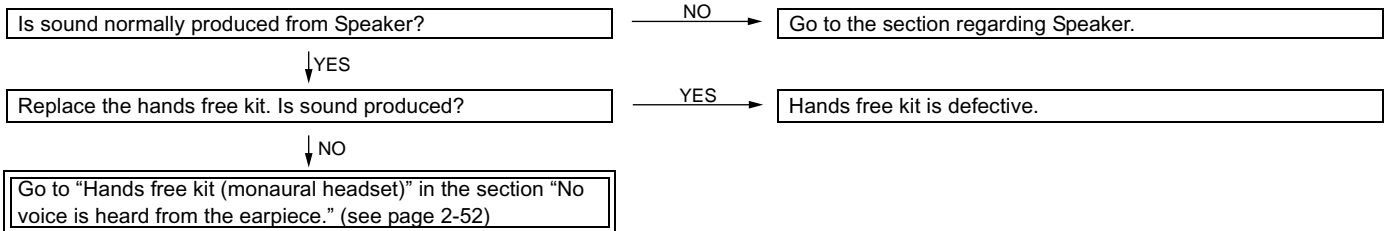

9. Video/Voice Recorder playback is impossible.

Speaker

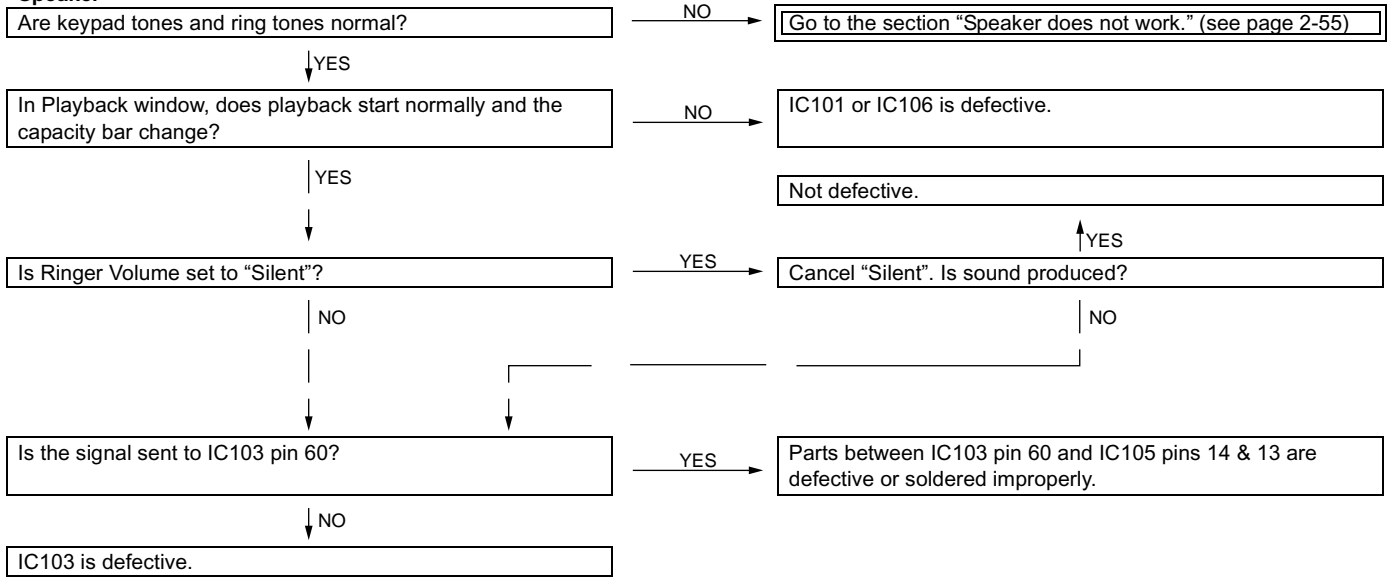

Hands free kit (headset)

* If R-ch is the only channel of stereo headset that does not send signals, see "Hands free kit (stereo headset) - Option" in the section "No voice is heard from the earpiece." (see page 2-53)

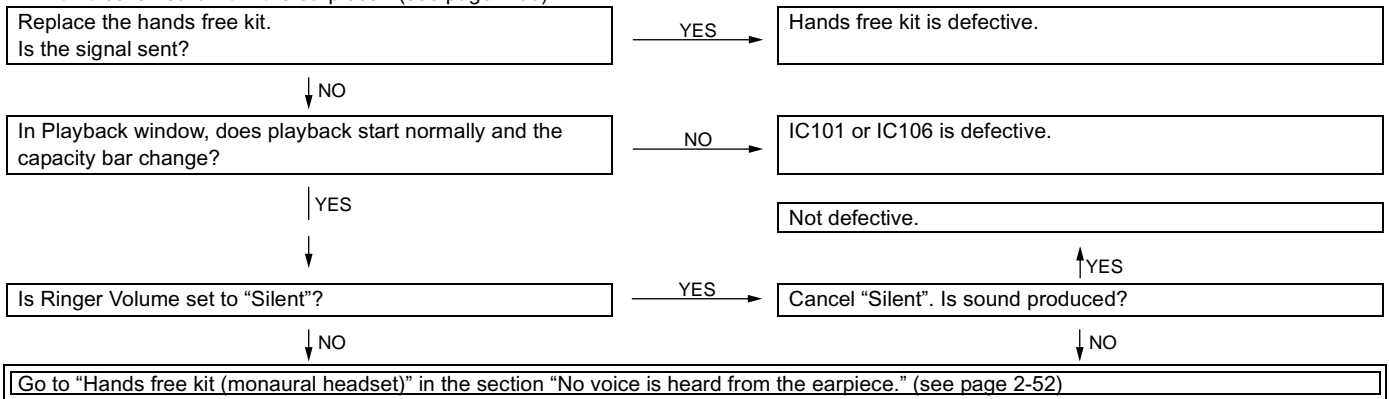

10. Back Light does not turn on.

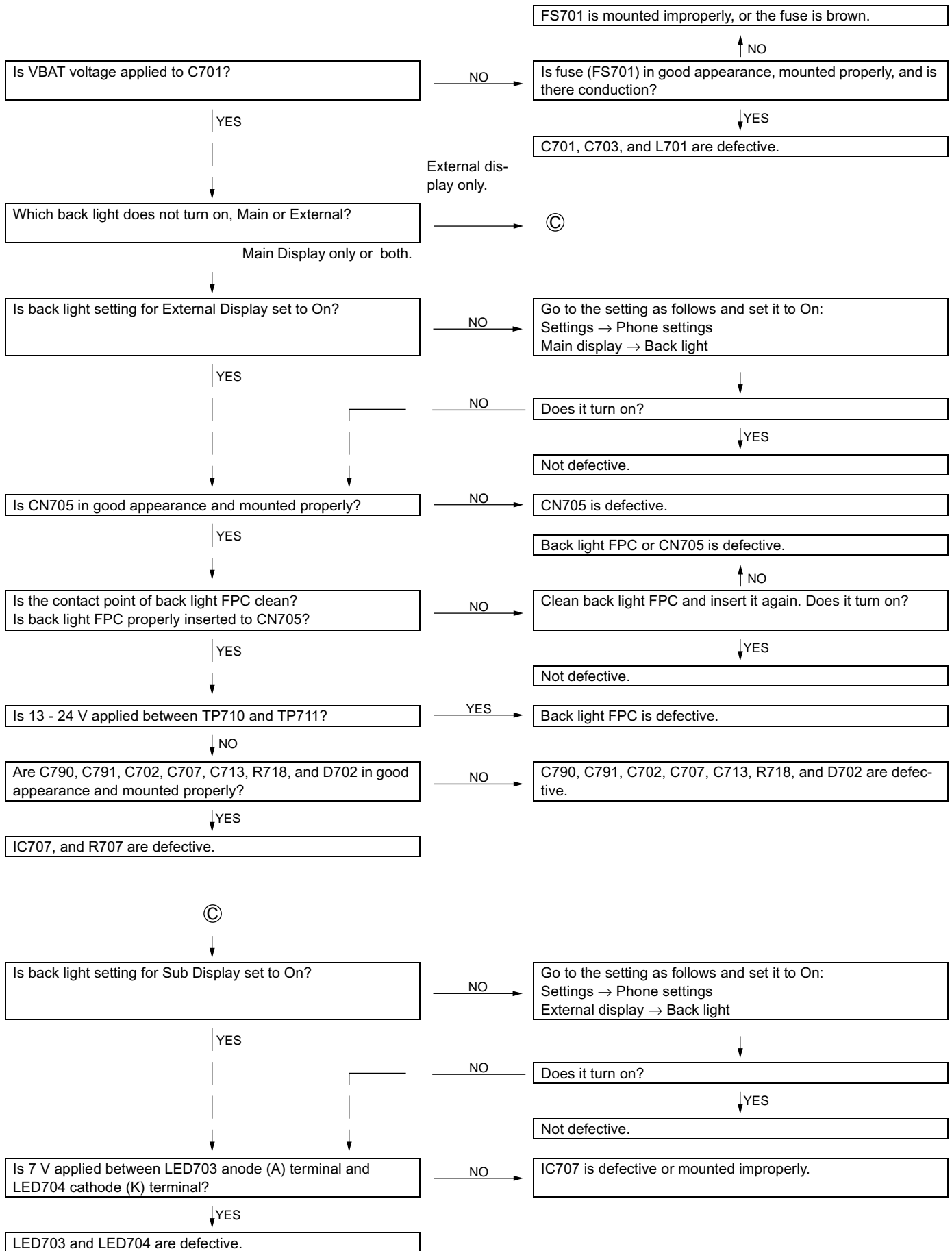

11. Out of range and incoming/outgoing calls are impossible.

[Checkpoints in RF Test Tool]

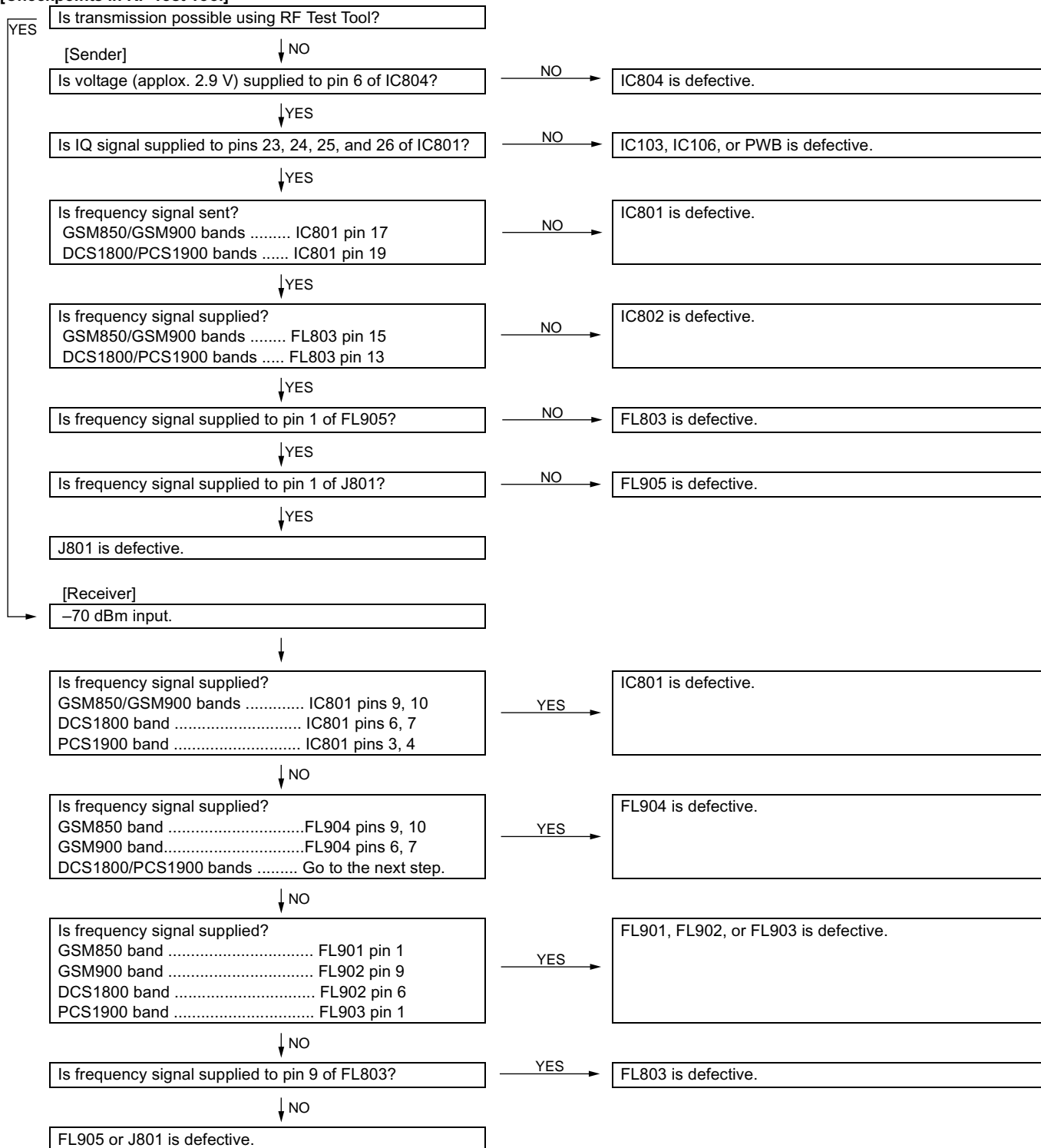

12. The display does not appear on Main Display.

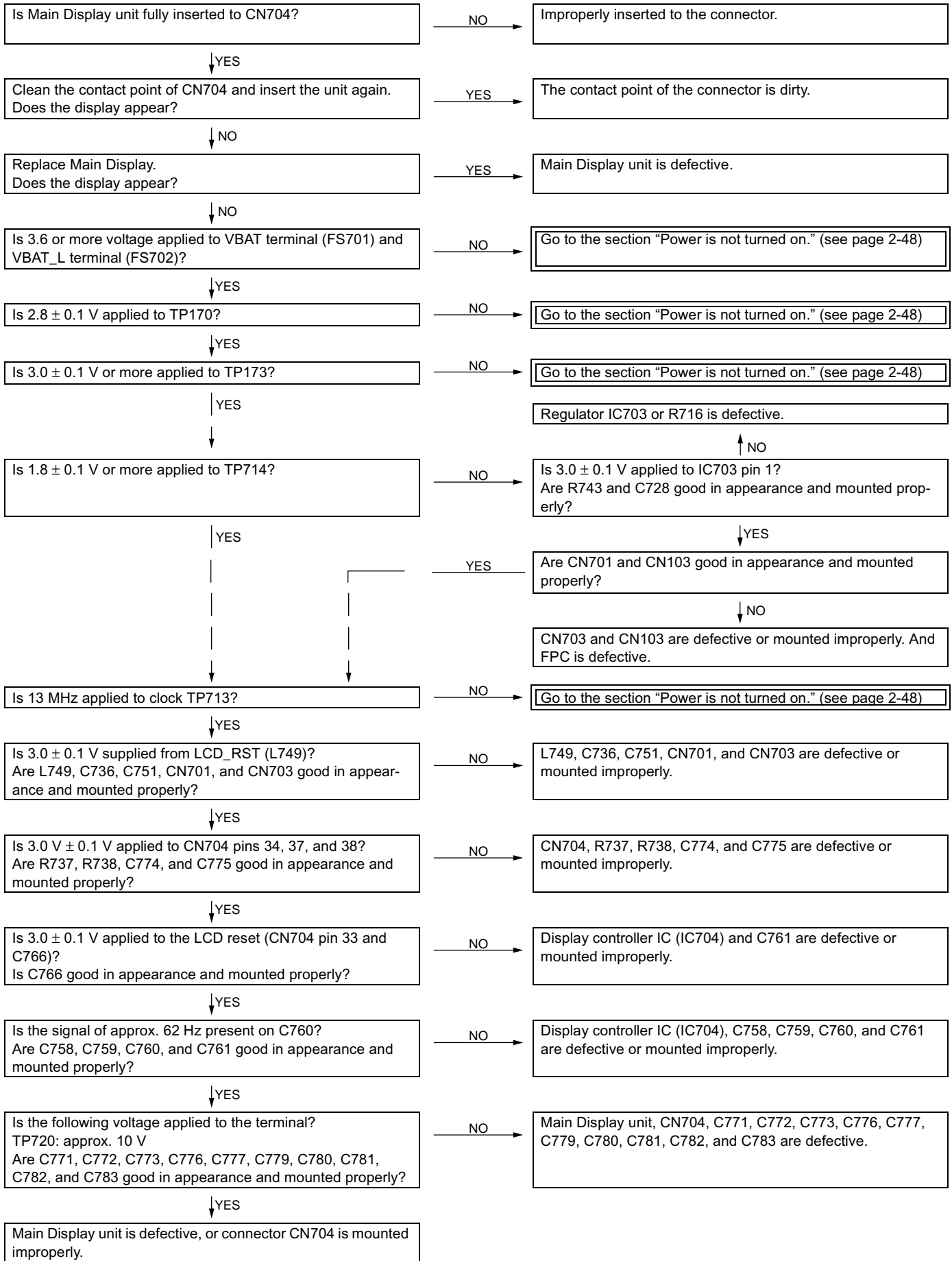

13. The display does not appear on External Display (in 65K color mode).

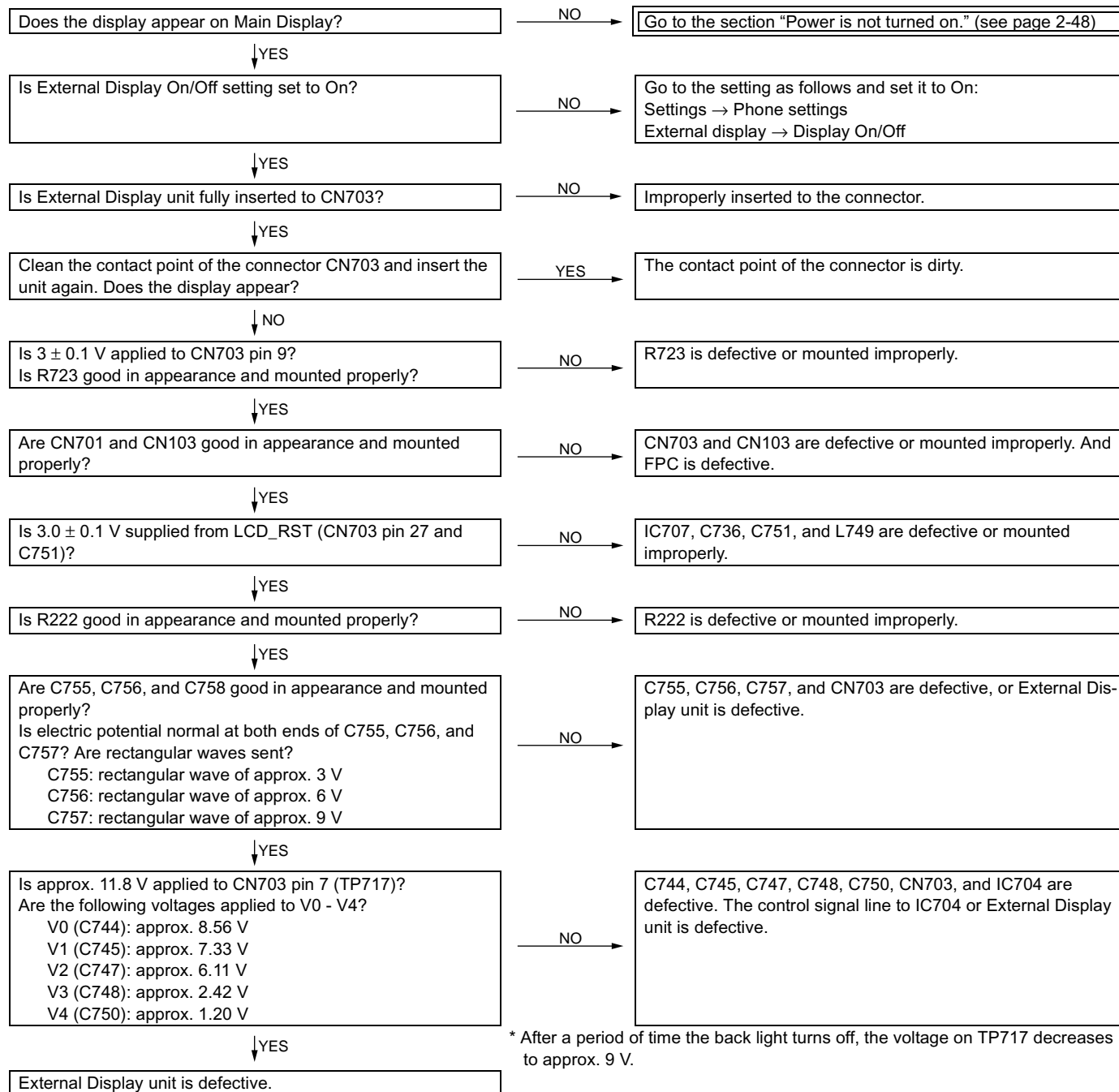

14. Pictures cannot be taken.

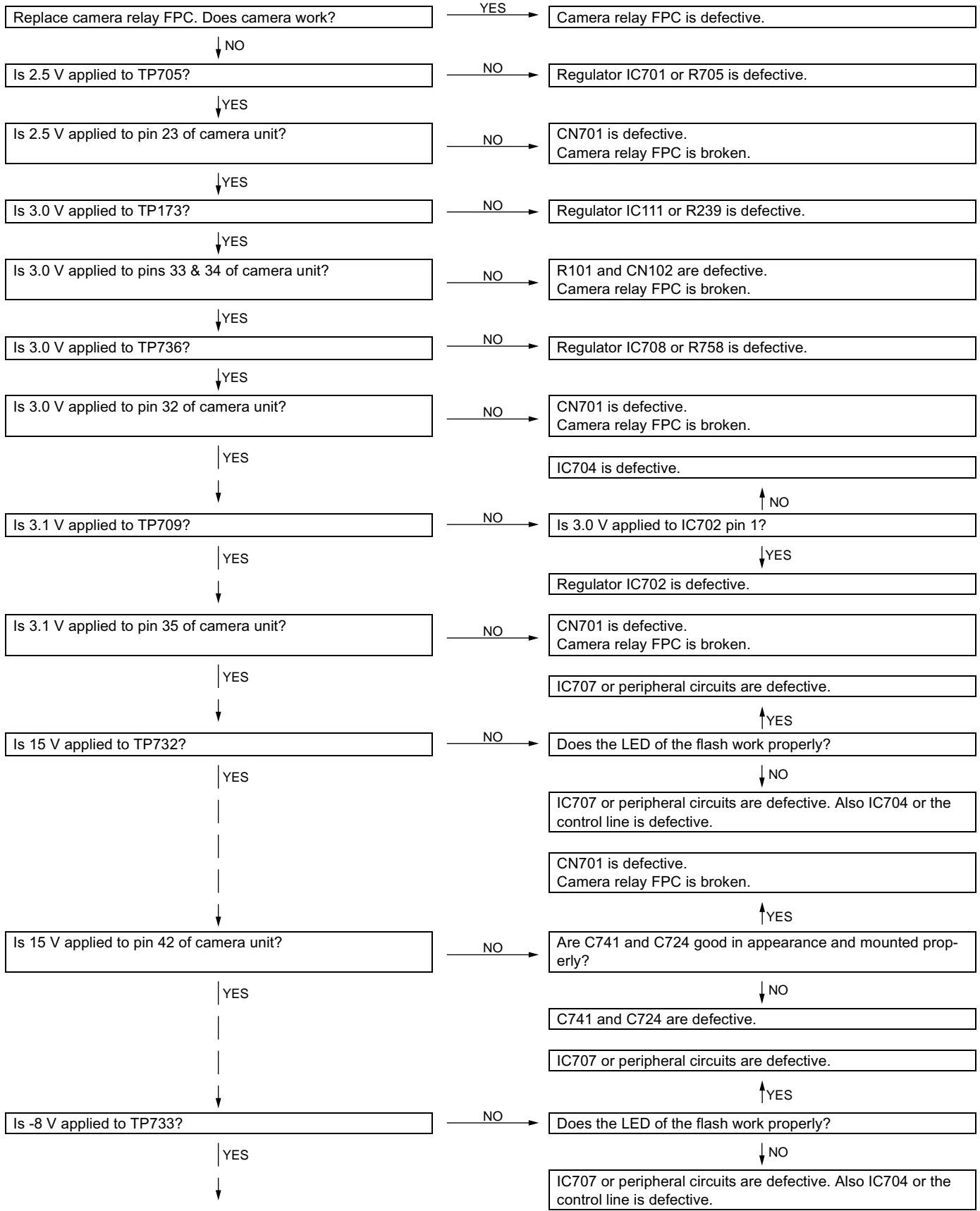

ⓐ
(To page 2-63)

(From page 2-62)

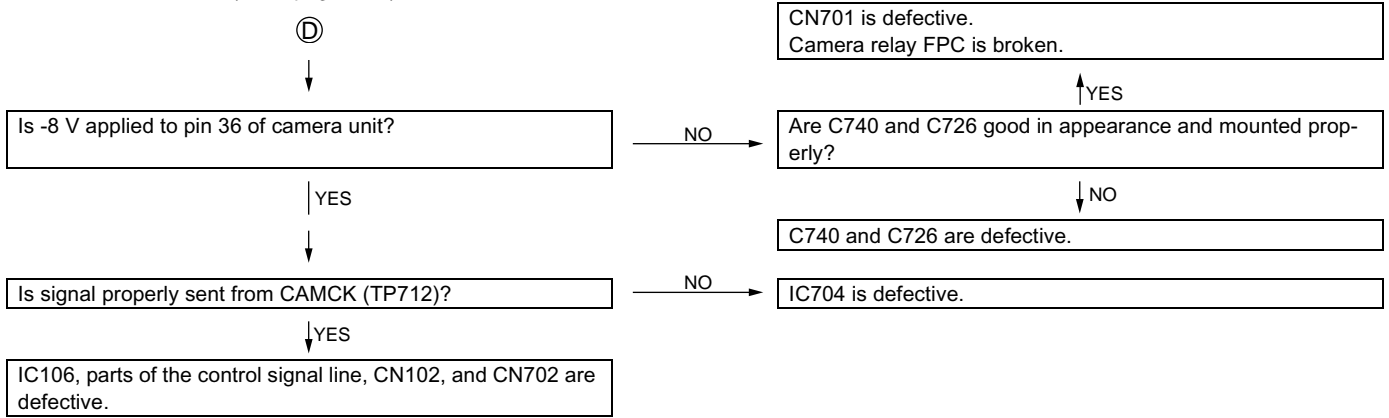

15. Flash light does not work.

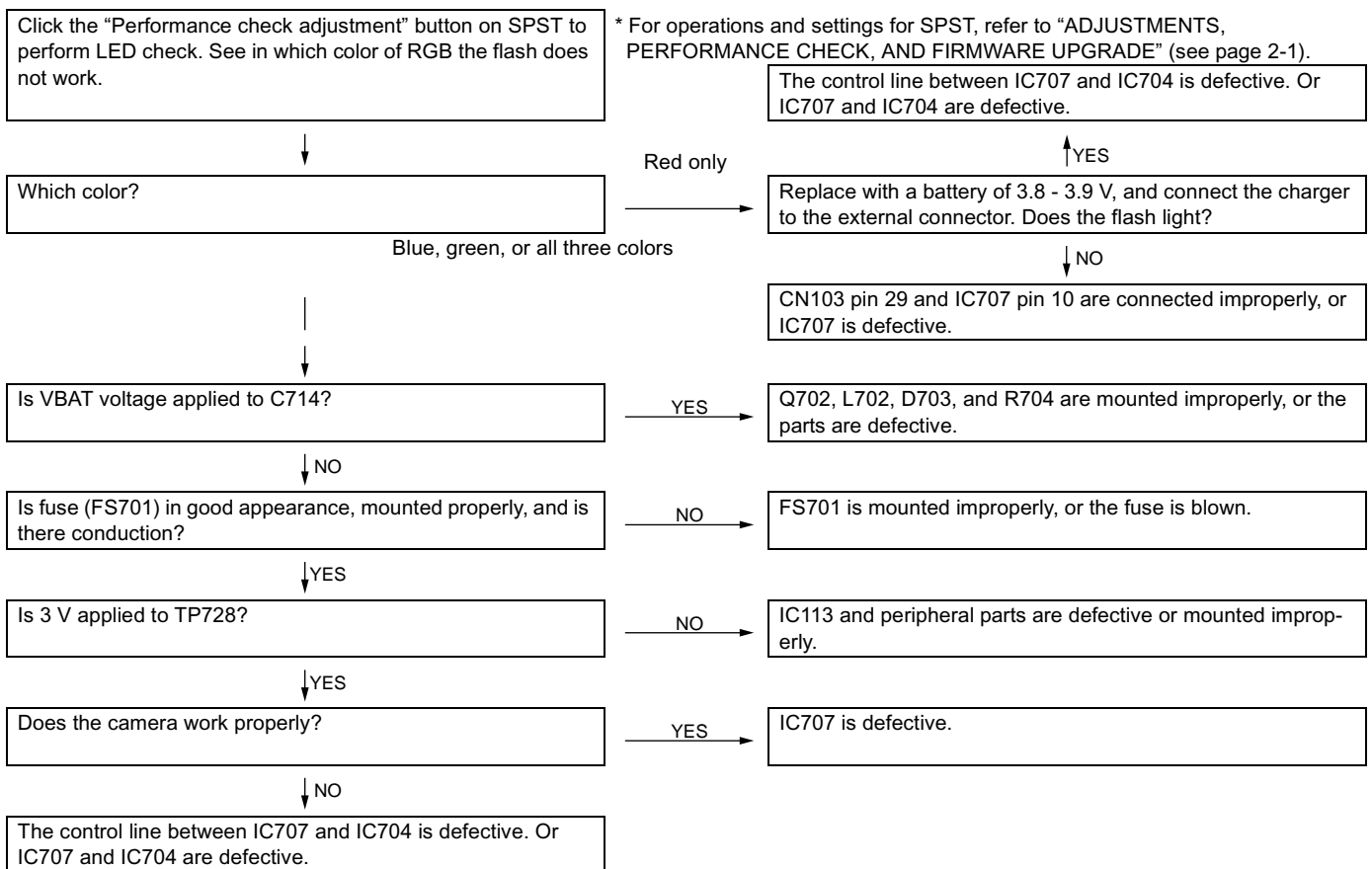

* For operations and settings for SPST, refer to "ADJUSTMENTS, PERFORMANCE CHECK, AND FIRMWARE UPGRADE" (see page 2-1).

Red only

Blue, green, or all three colors

YES

NO

NO

YES

NO

YES

NO

YES

NO

16. SIM card is not recognized.

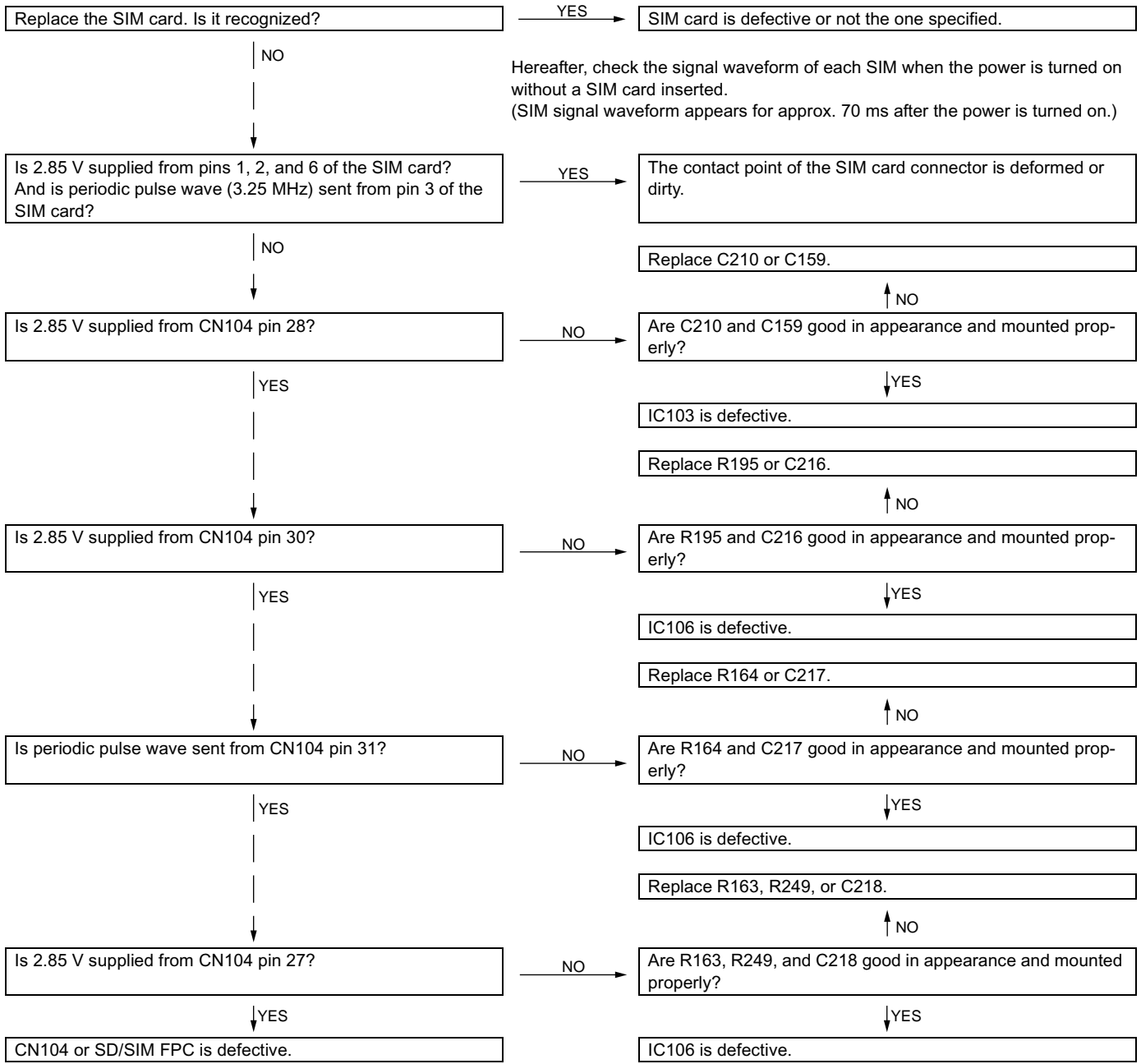

17. SD (Memory) card is not recognized.

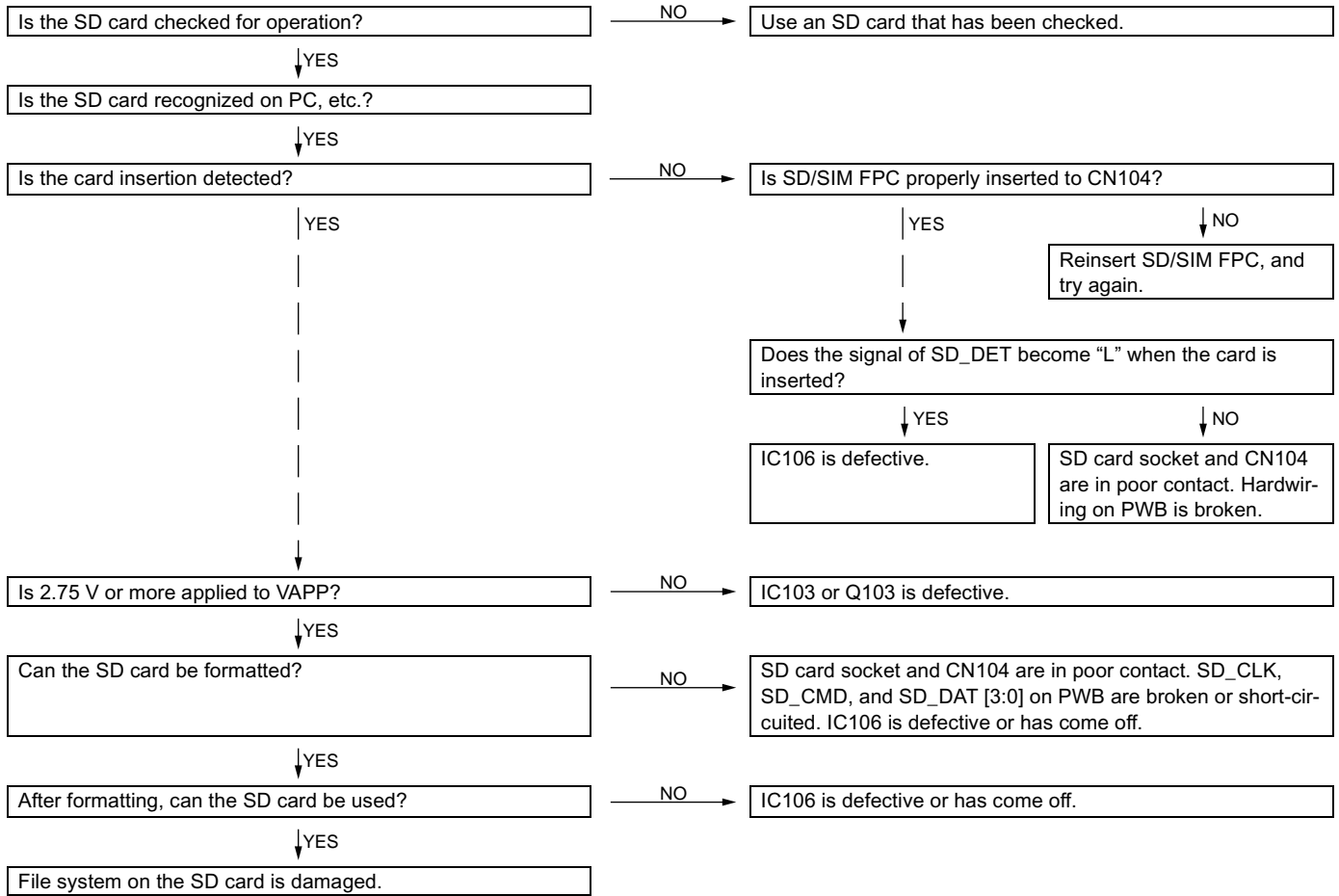

18. IrDA (Infrared) communication is not possible.

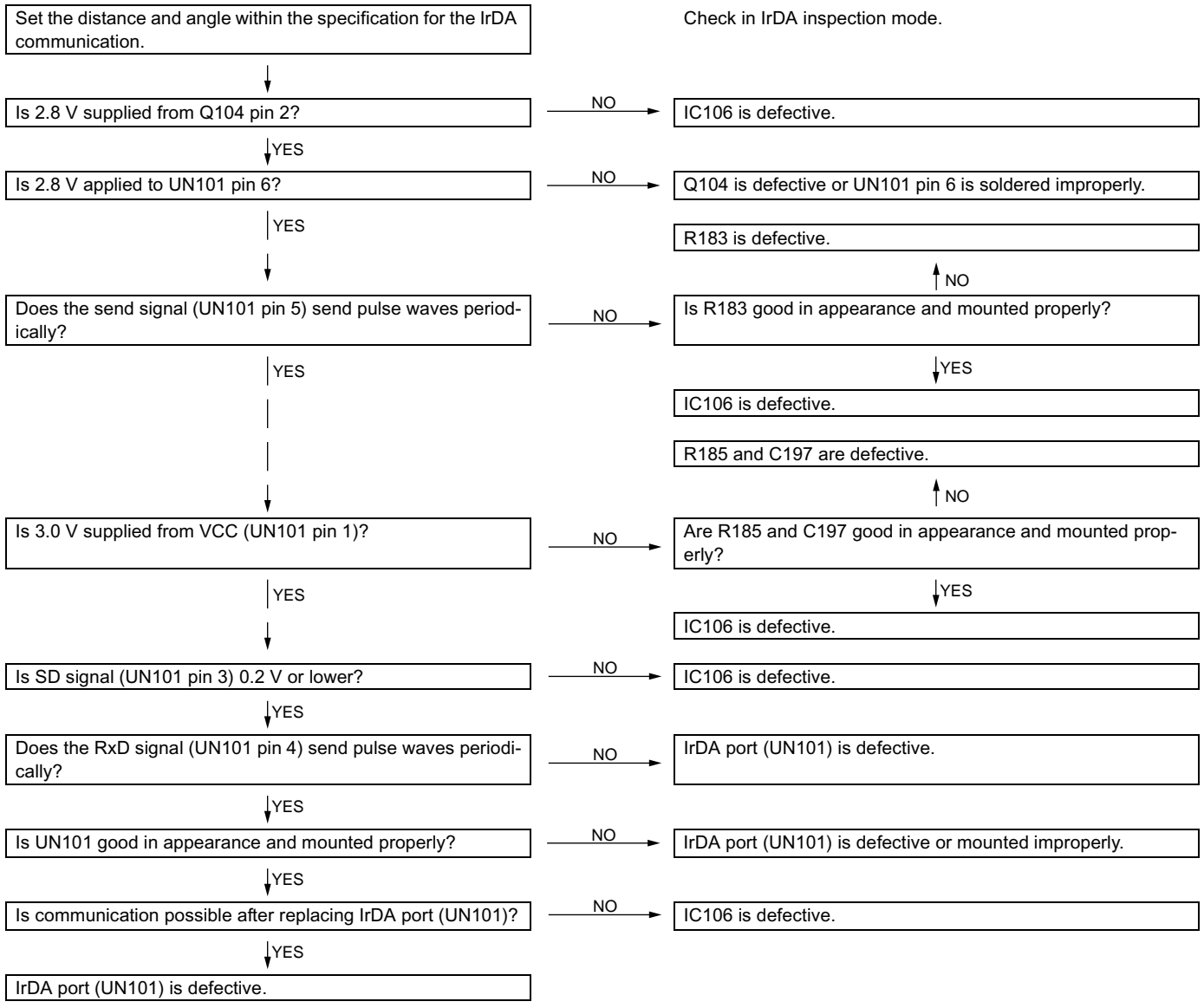

Check in IrDA inspection mode.

19. Bluetooth communication is impossible.

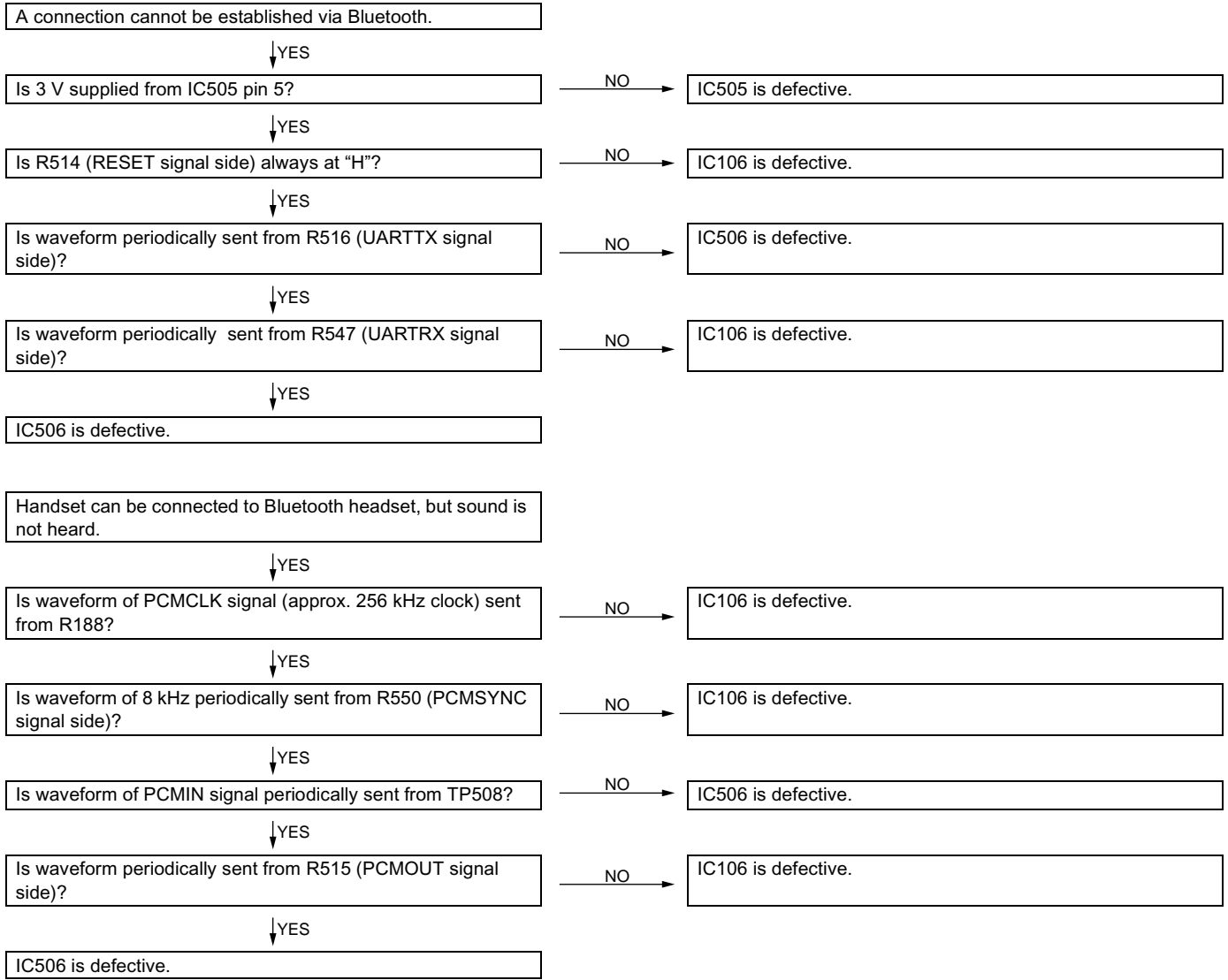

20. USB connection is impossible.

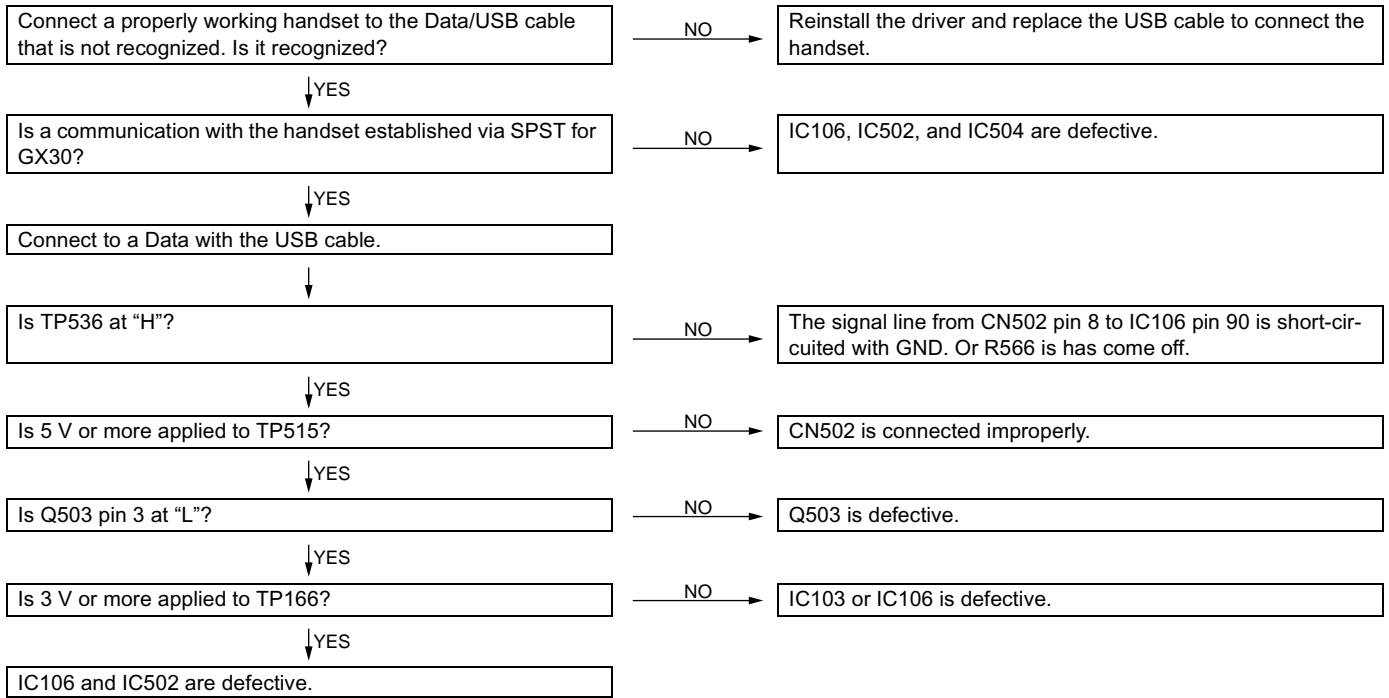

CHAPTER 3. DISASSEMBLY AND REASSEMBLY

[1] Servicing Concerns

1. For disassembling

1. Please do not remove the board of base band section by pulling external interface connector, otherwise you will make damage to the board.
2. Shield case is attached on shield case holder without clearance. When you remove it, please take care not to remove together with shield case holder. If you remove shield case holder together, you can not attach it again because it is attached by solder and in such a case, you should have taken electric pattern on the board as well.

2. For reassembling

1. Please make sure that all cosmetic parts have no scratch and clean.
2. Please make sure that you can open and close handset smoothly and hear tick sound of hinges.
3. Please make sure that main screen display panel is placed in proper position without inclination.
4. Please make sure that all three battery terminals protrude evenly.
5. Please make sure that the pawl of aerial is upside.

FASTENING TORQUE (Referential Value)

• Back Cabinet (Key)/ Front Cabinet (Key)	17.6 ± 2 N • cm (1.8 ± 0.2 Kgf • cm)
• Back Cabinet (Display)/ Front Cabinet (Display)	

The value is for reference when an electric screwdriver (HIOS CL4000) is used.

SOLDERING SPECIFICATION

Soldering iron must be set to 350° C for 5 seconds.

NOTES FOR REPLACING THE EARPIECE

1. When replacing the earpiece, make sure the earpiece sheets (B) are removed. Also, attach the earpiece sheet (A) to the specified position.
2. When replacing the front cabinet (display) with the earpiece sheets (B), replace the earpiece at the same time.
3. The earpiece sheets (B) is not supplied.

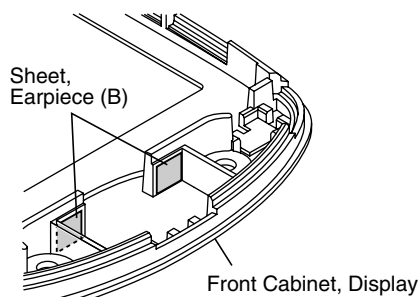
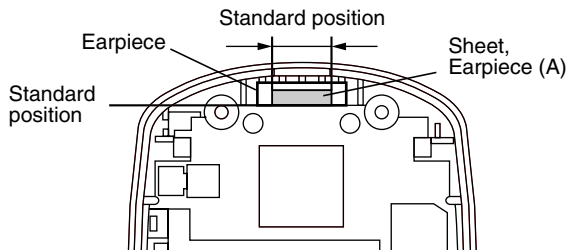

MOUNT THE PWB

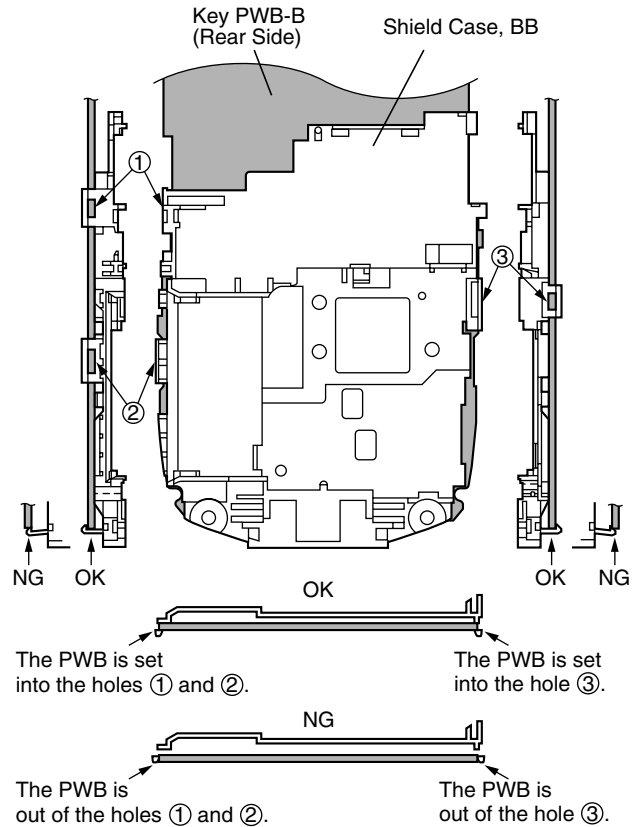

STANDARD POSITION OF ATTACHMENT

When replacing the following labels (marked with), be sure to put new ones on the specified positions.

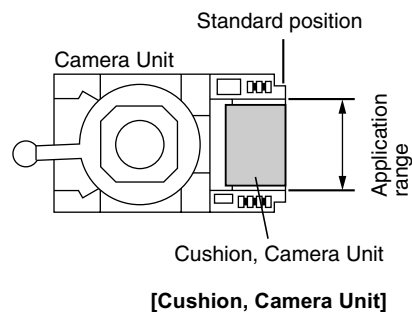
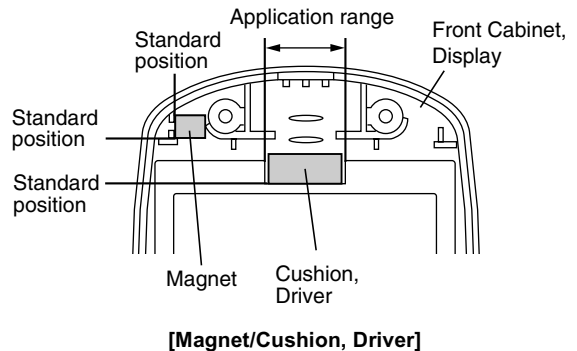

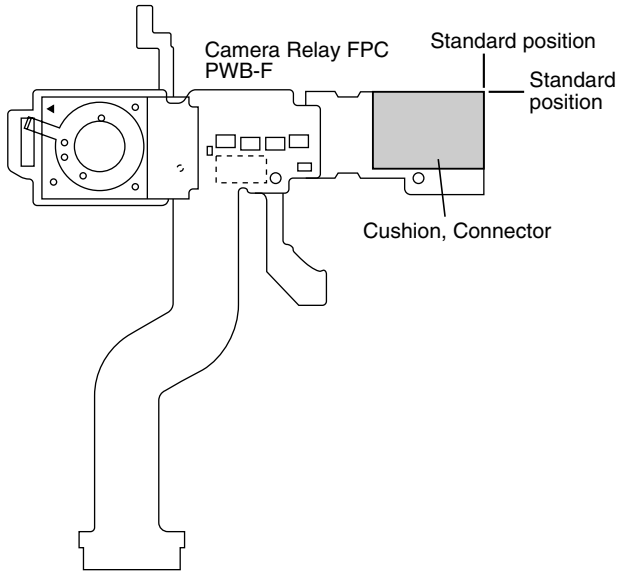

[Cushion, Connector]

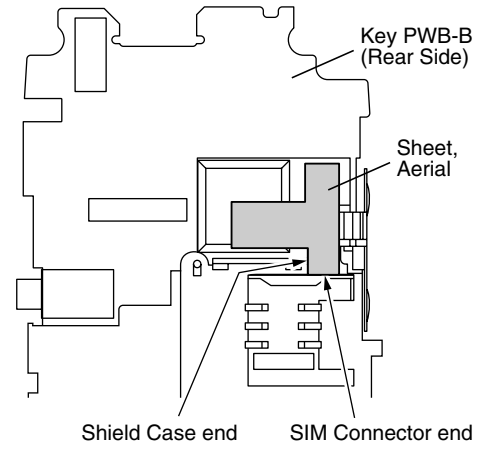

[Sheet, Aerial]

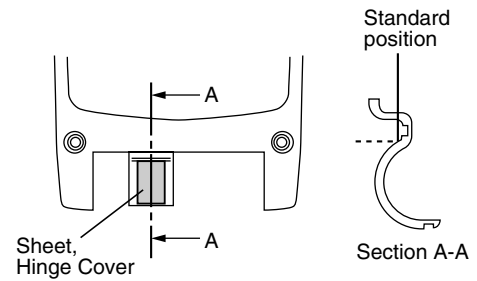
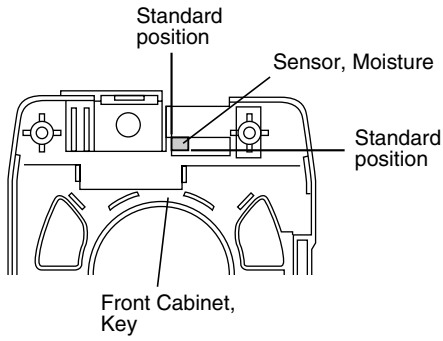

[Sheet, Hinge Cover]

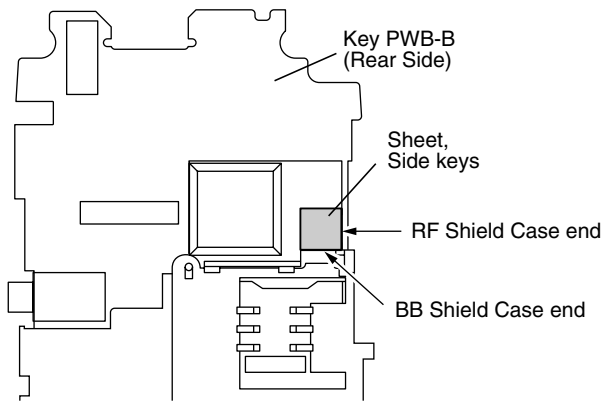

[Sensor, Moisture/Sheet, Side keys]

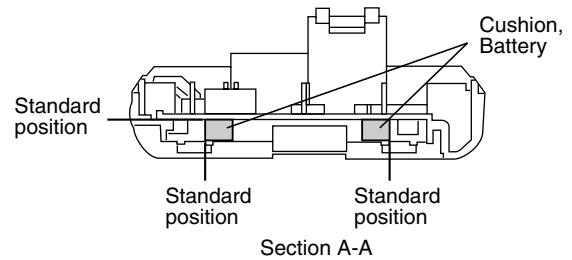

[Cushion, Battery]

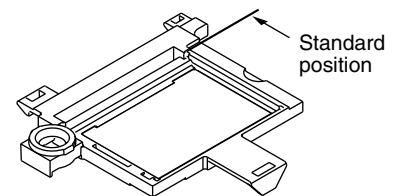
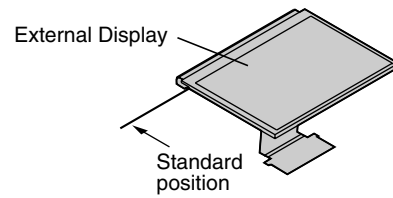

[External Display]

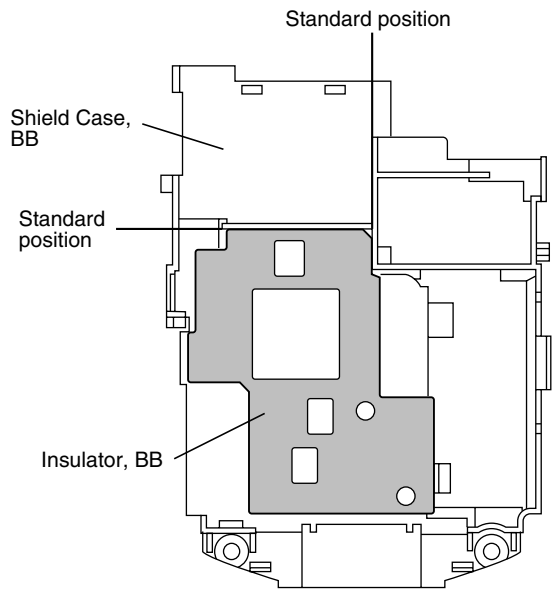

[Insulator, BB]

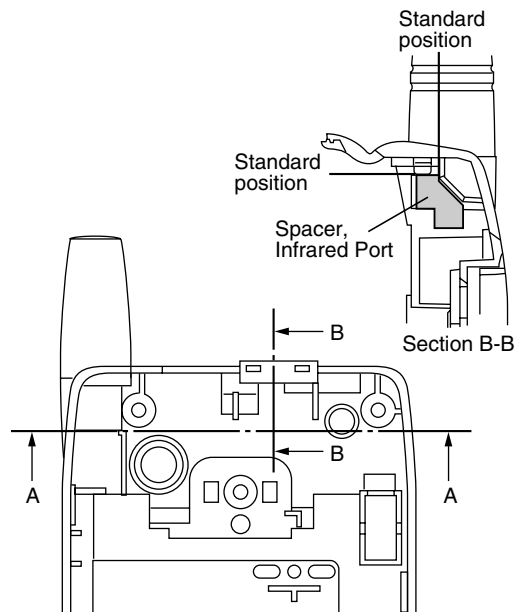

[Spacer, Infrared Port/Tape Infrared Port]

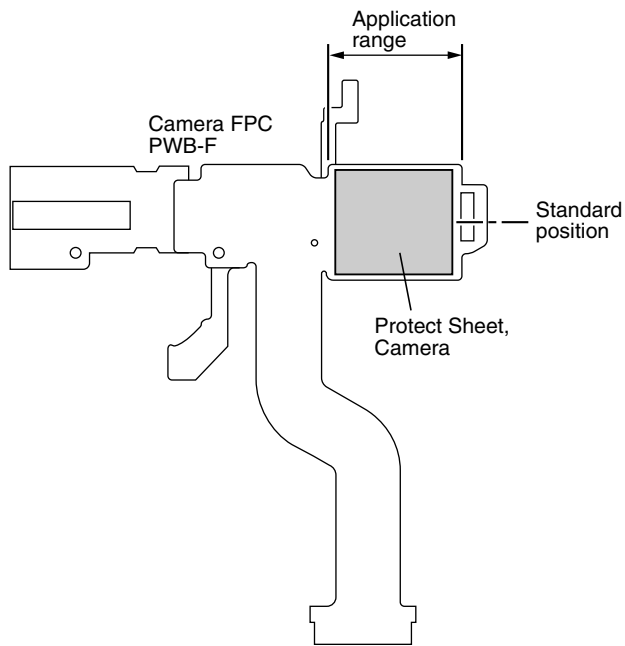

[Protect Sheet, Camera]

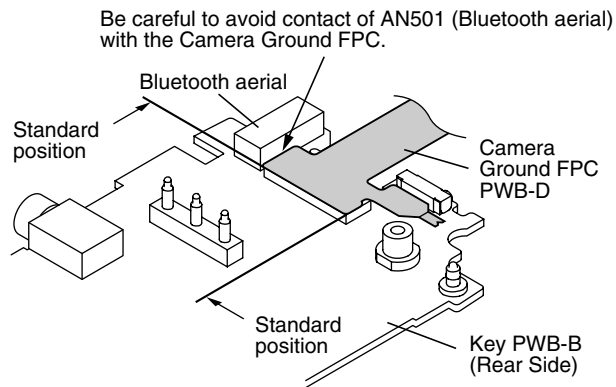

[Camera Ground FPC PWB-D]

[2] Disassembly and reassembly

• To reassemble, follow the reverse procedure.

STEP	REMOVAL	PROCEDURE	FIGURE
1	Back Cabinet (Key) Ass'y	1.Battery Cover..... (A1)x1 2.Li-Ion Battery..... (A2)x1 3.Screw Cover..... (A3)x2 4.Screw..... (A4)x4 5.Hook..... (A5)x4 6.Hook..... (A6)x1	1 2
2	SD Card Cover Belt	1.Stoper..... (B1)x1 2.Hook..... (B2)x4	3
3	Aerial	1.Aerial Cover..... (C1)x1 2.Hook..... (C2)x1	4

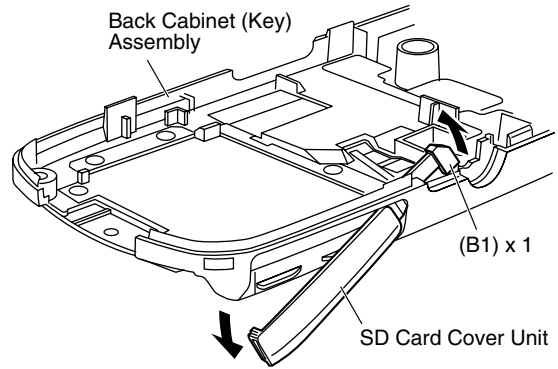

Open the SD card cover and turn it as indicated by the arrow to release the stopper. Then pull out the cover downward. Remove the SD cover belt as instructed below.

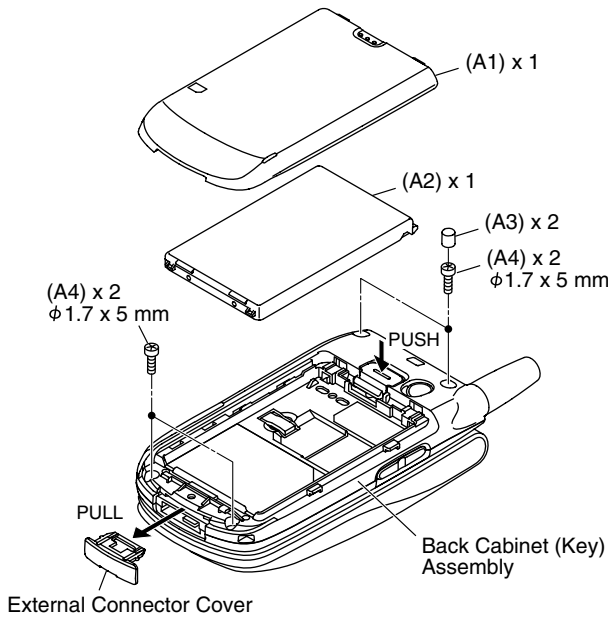

Figure 1

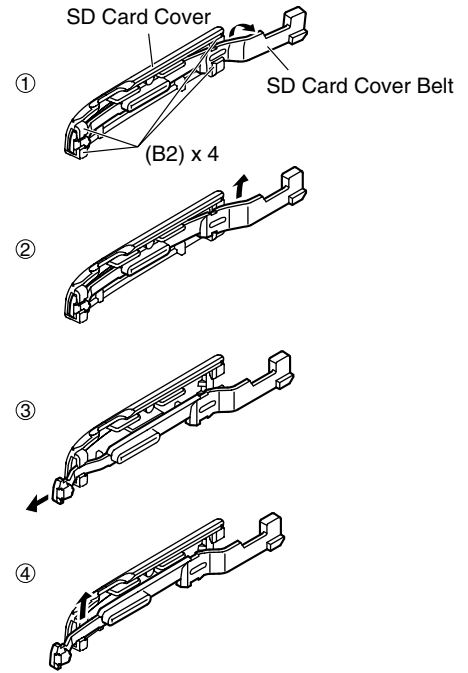

Figure 3

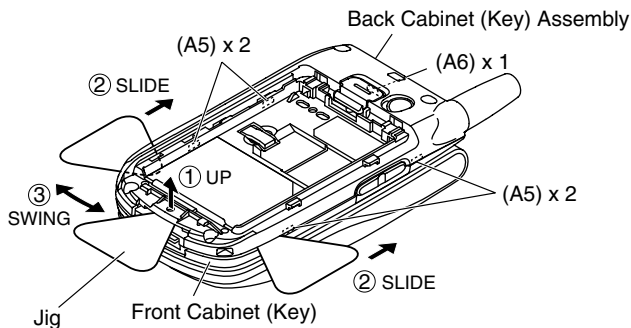

Figure 2

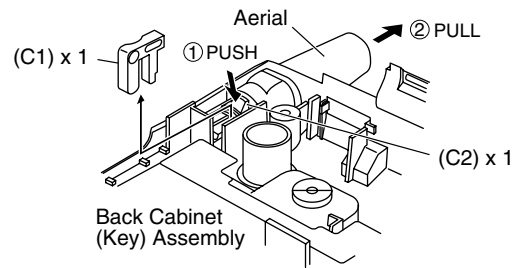

Figure 4

(Use something flat and hard, for example guitar picks.)

- Remove the external connector cover. Insert a jig into the slot and slightly lift up the back cabinet (key) assembly.
- Insert jigs into the space. Slide jigs on the both sides to release 4 hooks (A5).
- Move the cabinet assembly gently from side to side to release the other hook (A6).

STEP	REMOVAL	PROCEDURE	FIGURE
4	Key PWB-B	1. Jack Cover 2. Side Key 3. Hook..... (D1)x7 4. Solder..... (D2)x1 5. Flat Cable..... (D3)x3	5
5	SD/SIM FPC PWB-G	1. Hook..... (E1)x1 2. Hook..... (E2)x2	6
6	BB Shield Plate	1. Hook..... (F1)x1	7

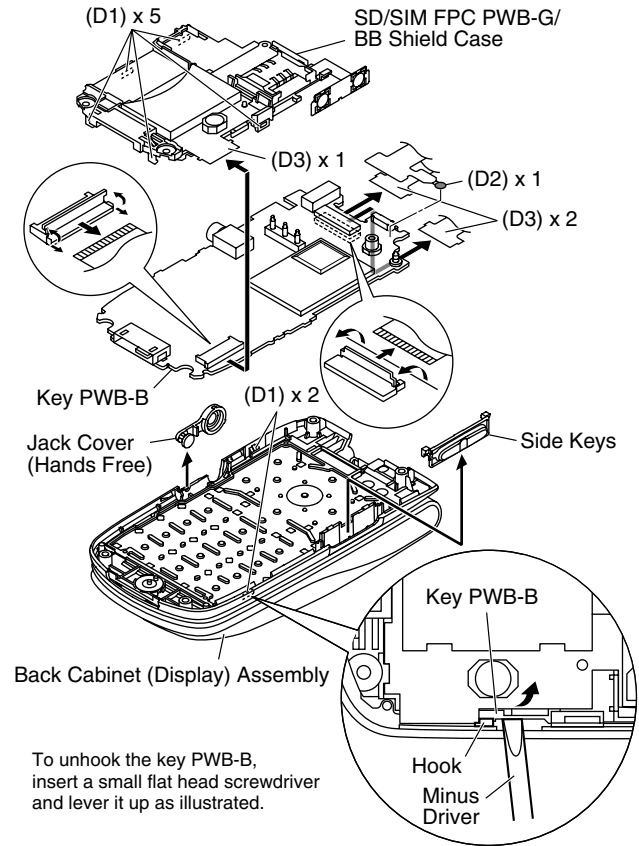

Figure 5

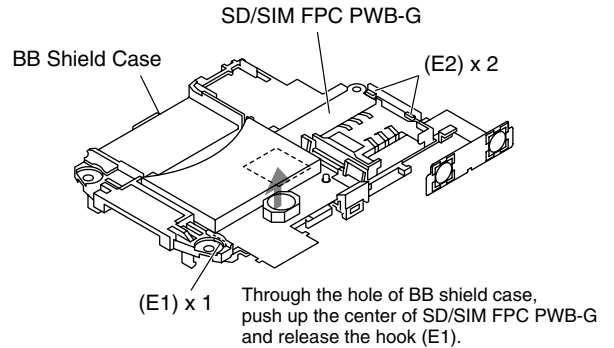

Figure 6

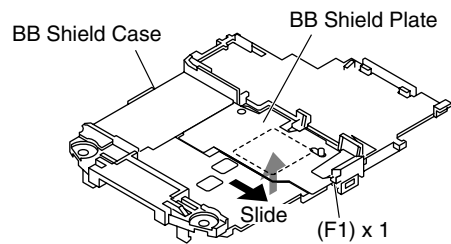

Figure 7

STEP	REMOVAL	PROCEDURE	FIGURE
7	Back Cabinet (Display)	Open the handset 1.Screw Cover..... (G1)x3 2.Screw..... (G2)x4 Close the handset 3.Hook..... (G3)x4 4.Hook..... (G4)x1	8 9
8	Main PWB-A Unit	Open the handset 1.Hook..... (H1)x2	10

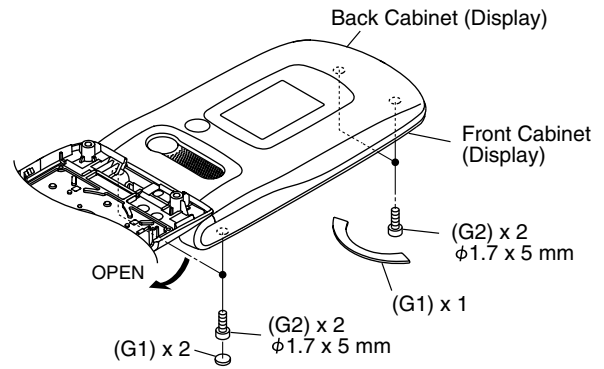
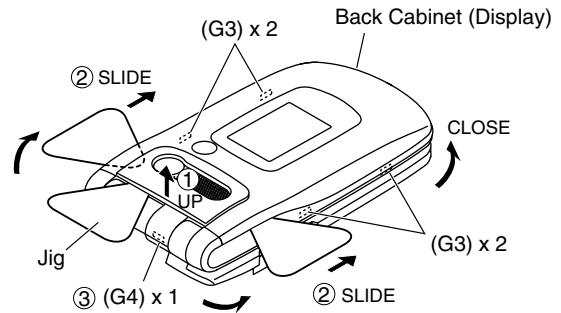

Figure 8



- ① Insert a jig into the gap and slightly lift up the back cabinet (display) assembly.
- ② Insert jigs into the space.
Slide them in the direction of the arrow to release 4 hooks (G3).
- ③ Being careful with the claw, release the hook (G4).

Figure 9

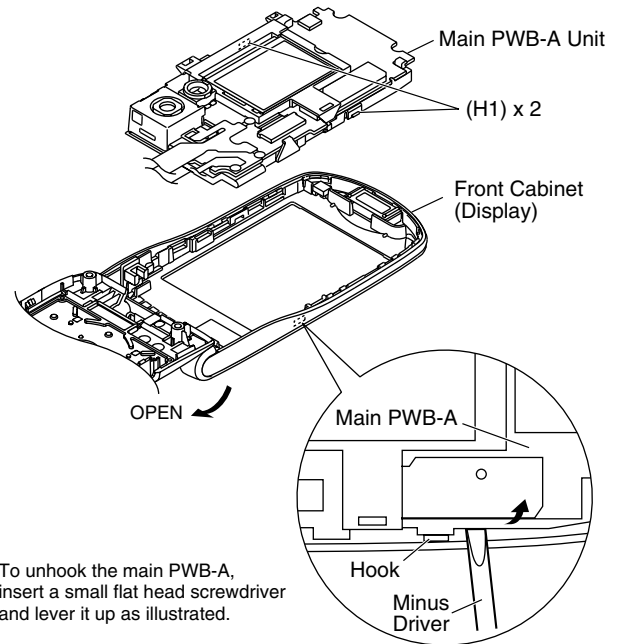

Figure 10

STEP	REMOVAL	PROCEDURE	FIGURE
9	Main PWB-A	1.Socket..... (I1)x1 2.Solder..... (I2)x3 3.Hook..... (I3)x7 4.Flat Cable..... (I4)x3	11
10	Front Cabinet (Key)/ Front Cabinet (Display)	1.Side Frame..... (J1)x1 2.Hinge..... (J2)x2	12

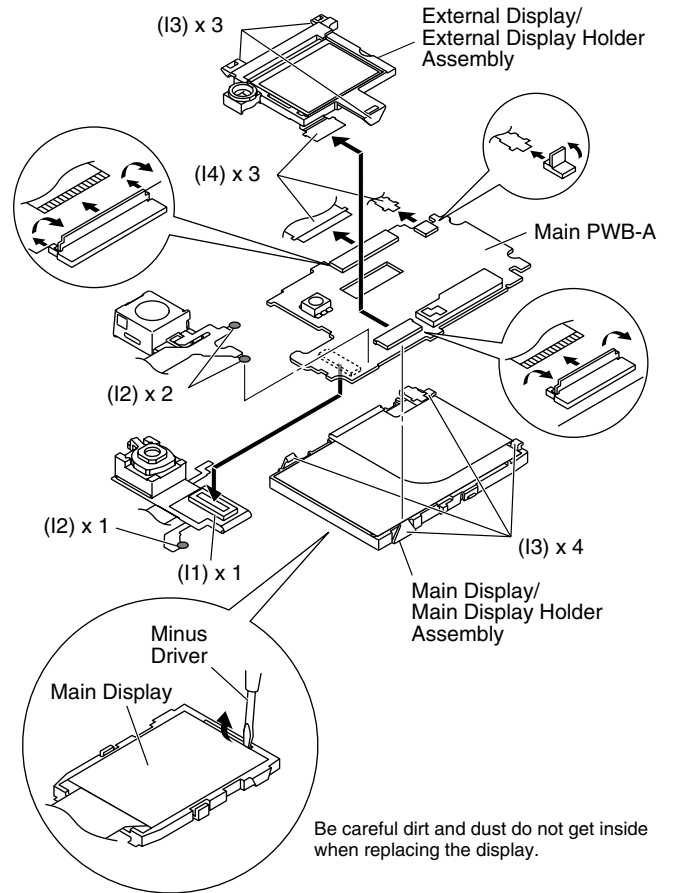

Figure 11

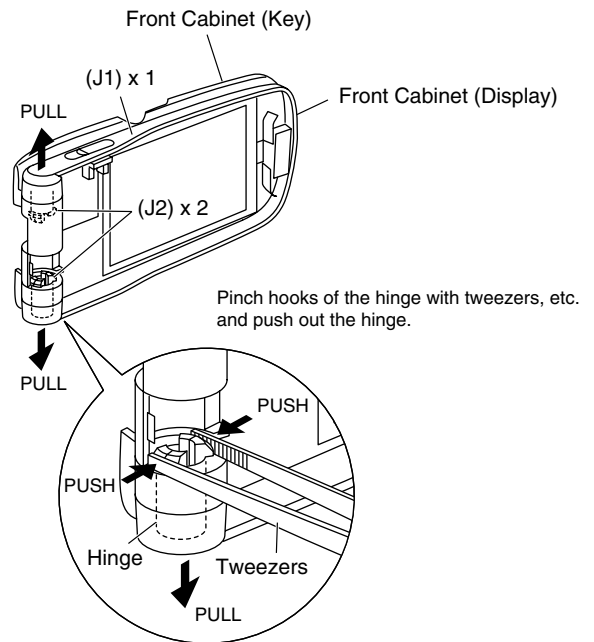

Figure 12

CHAPTER 4. DIAGRAMS

[1] Block diagram

[Main]

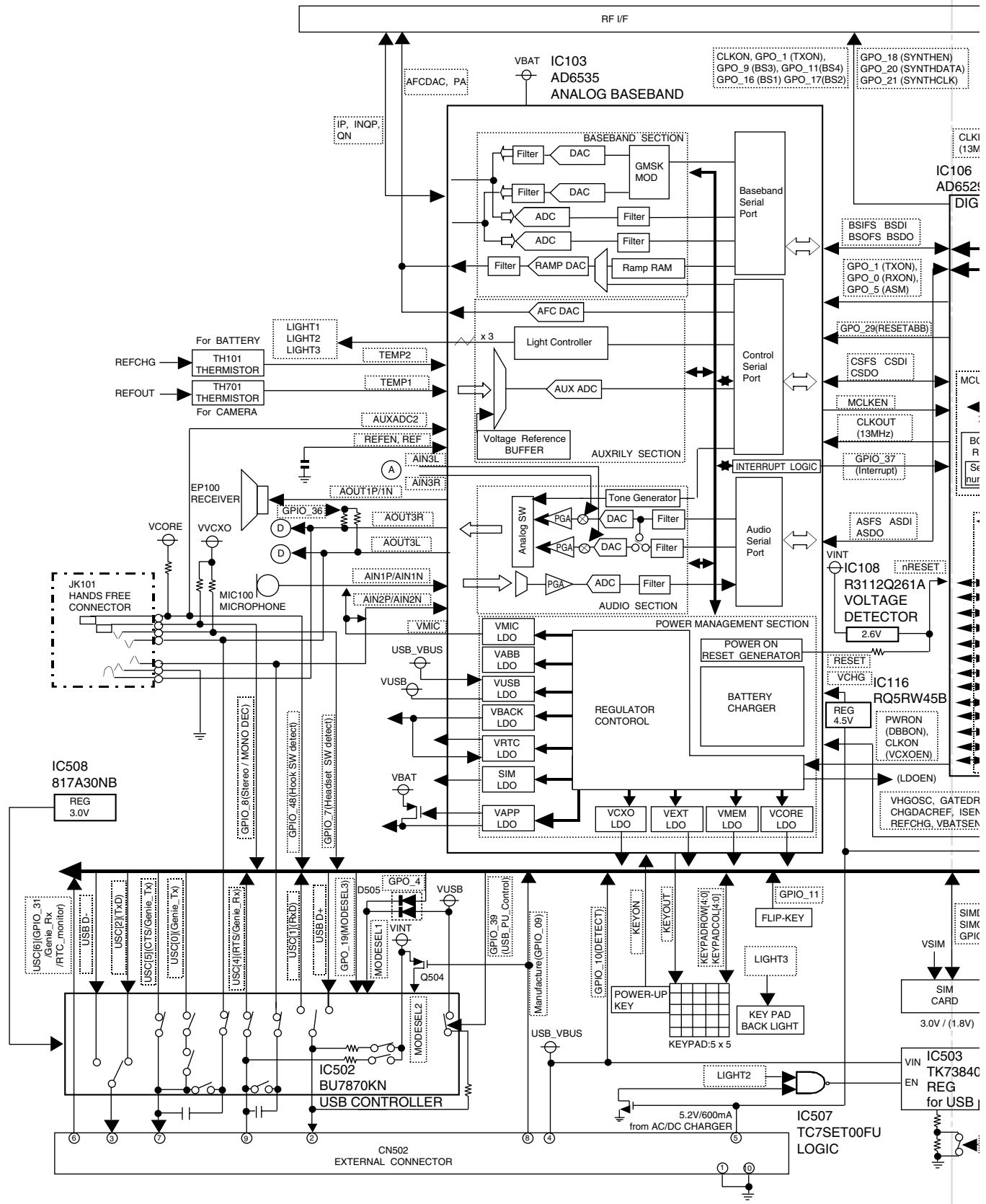

Figure 1 MAIN BLOCK DIAGRAM (1/2)

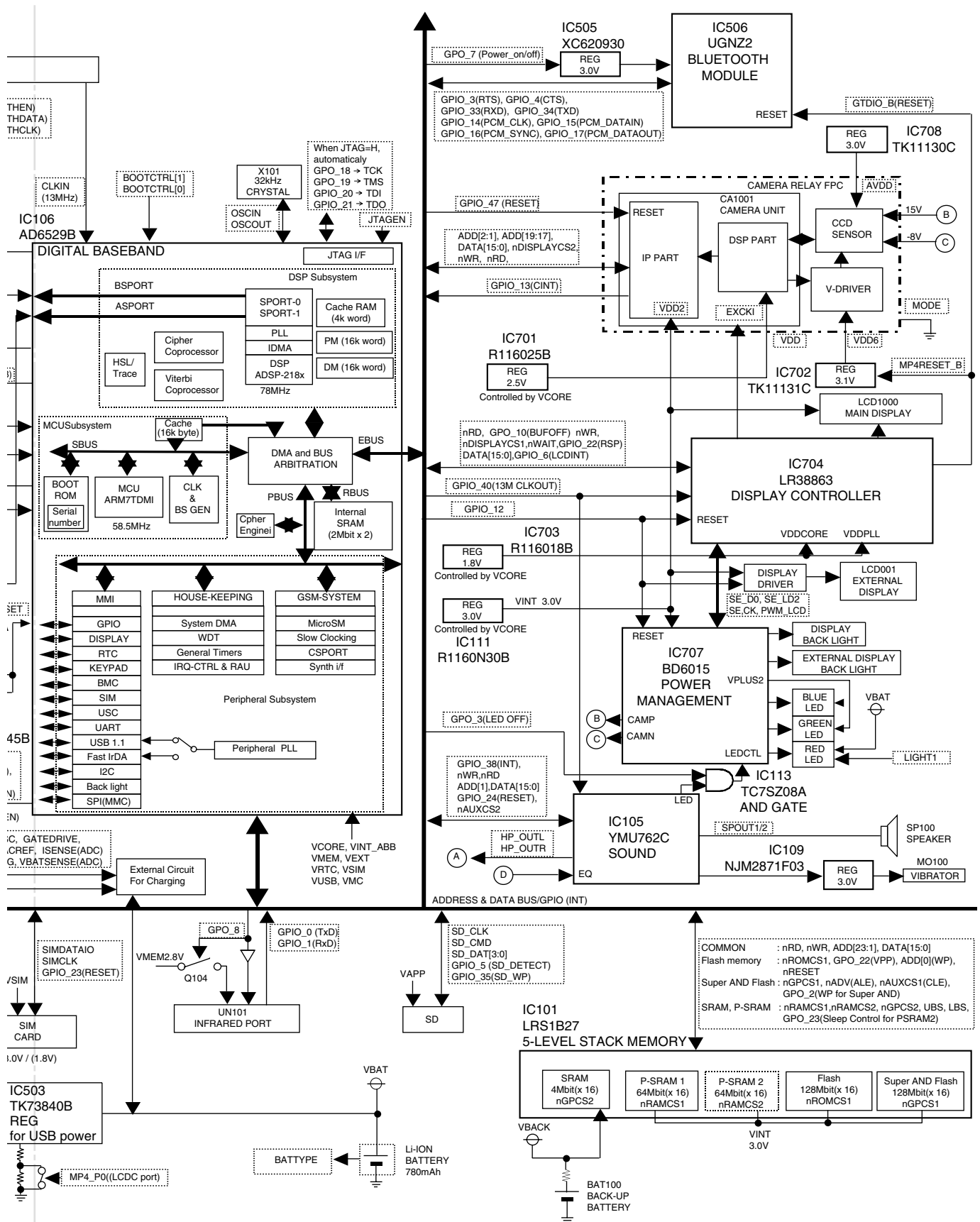

Figure 2 MAIN BLOCK DIAGRAM (2/2)

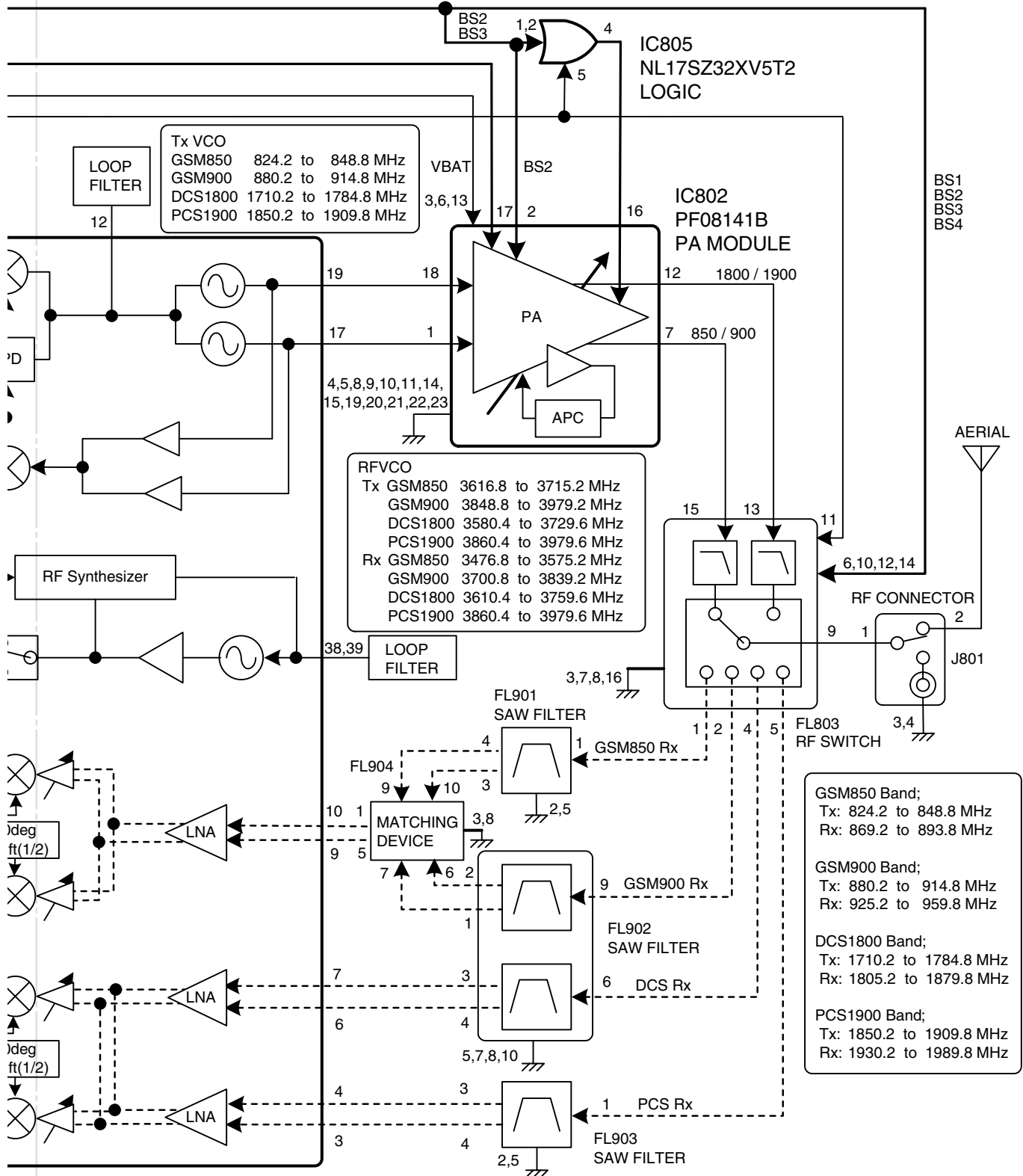

Figure 4 RF BLOCK DIAGRAM (2/2)

CHAPTER 5. SCHEMATIC DIAGRAM AND WIRING SIDE OF P.W.BOARD

[1] Notes on schematic diagram

• Resistor:

To differentiate the units of resistors, the symbols K and M are used. The symbol K means 1000 ohm and the symbol M means 1000 kohm. The resistor without any symbol is an ohm resistor.

• Capacitor:

To indicate the unit of capacitor, the symbol is used. The symbol P means pico-farad and the unit of the capacitor without such a symbol is microfarad. As to electrolytic capacitor, the expression "capacitance/withstand voltage" is used. (CH), (RH), (UJ): Temperature compensation (ML): Mylar type (S): Styrol type (PP): Polypropylene type

- The indicated voltage in each section is the one measured by Digital Multimeter between such a section and the chassis with no signal given.
- Conditions: SIM card inserted, power on, in stand-by mode (opened)
- Schematic diagram and Wiring Side of P.W. Board for this model are subject to change for improvement without prior notice.
- Parts marked with "△" are important for maintaining the safety of the set. Be sure to replace these parts with specified ones for maintaining the safety and performance of the set.

[2] Types of transistor and LED

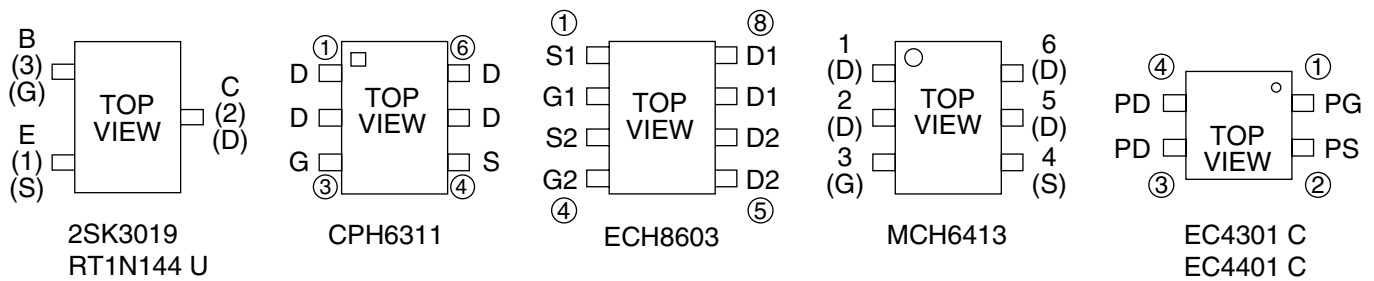

TOP VIEW

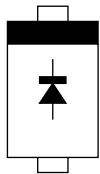

- 1SS388
1SS405
MA2SD31
MA2SD32
RB160M30
RB521S30
RB551V30

TOP VIEW

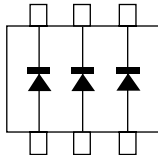

HN2S01FU

TOP VIEW

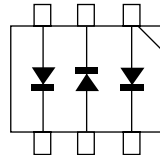

GM56271A

TOP VIEW

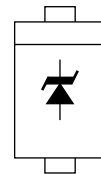

RSB6.8S

TOP VIEW

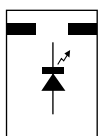

YPY1105C

TOP VIEW

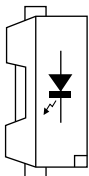

NECW008A

TOP VIEW

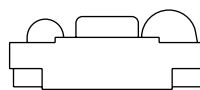

GP2W0116

[3] Waveforms of circuit

RF Test Tool
Tx test
Data pattern...TSC 5

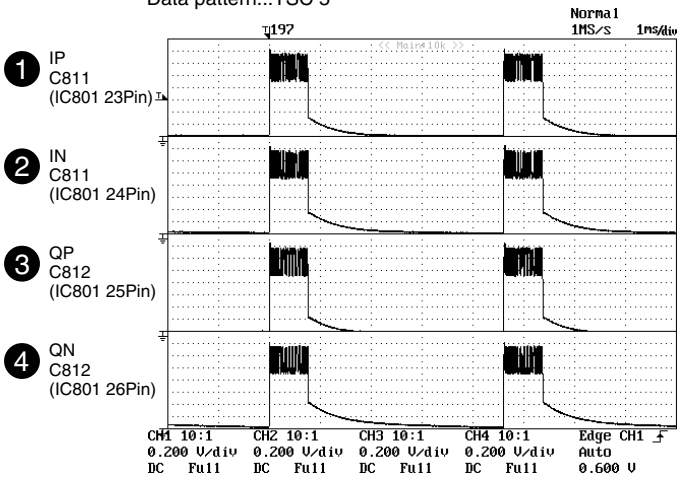

RF Test Tool
Tx test
GSM850, GSM900 Band

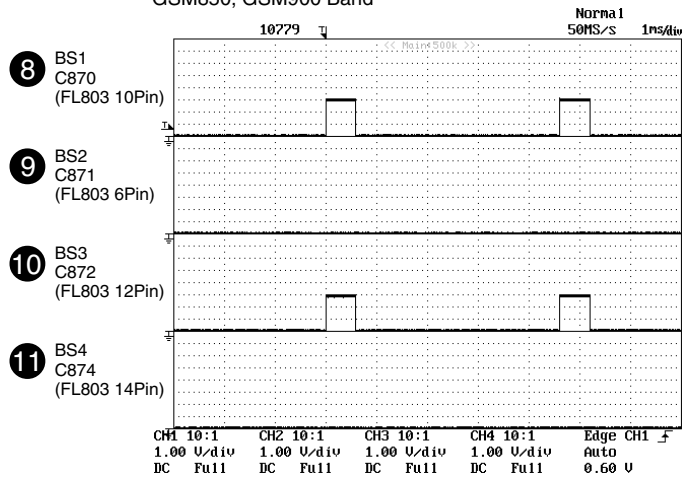

RF Test Tool
Rx Test
channel_62, Gain 64 dB, SniffOFF

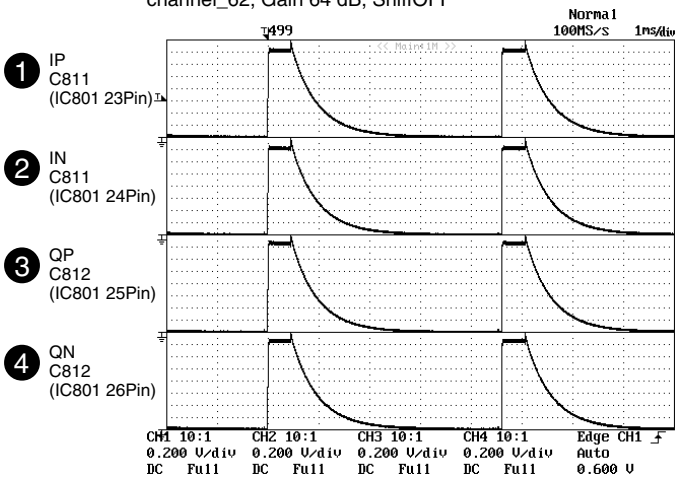

RF Test Tool
Tx test
DCS1800, PCS1900 Band

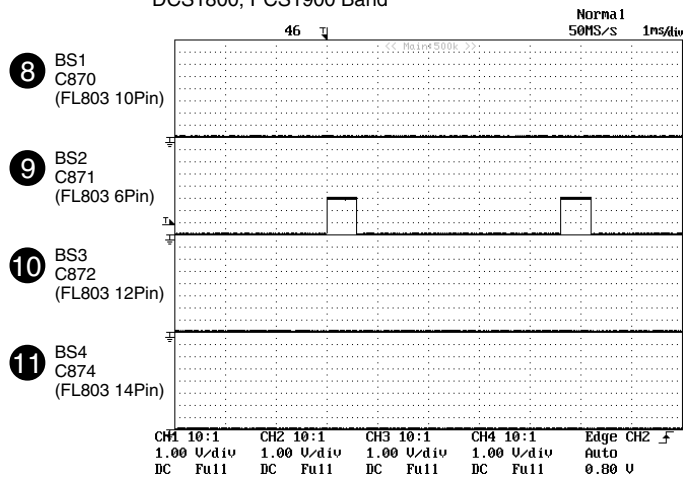

RF Test Tool
Rx Test
GSM900 Band (channel 62)

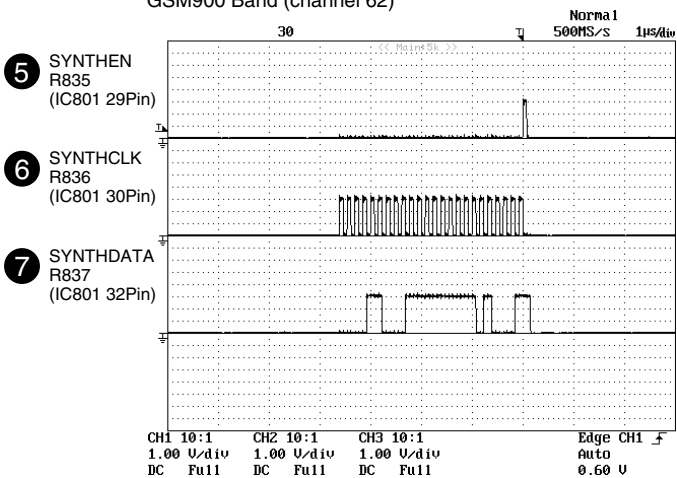

RF Test Tool
Rx test
GSM850 Band

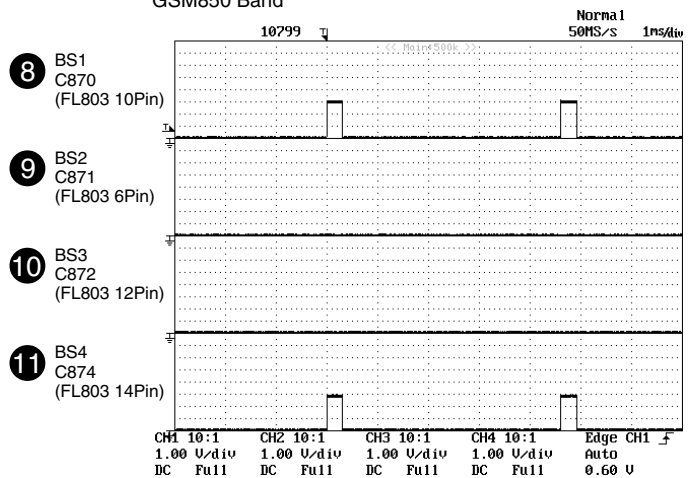

RF Test Tool
Rx test
GSM900, DCS1800 Band

- 8 BS1
C870
(FL803 10Pin)
- 9 BS2
C871
(FL803 6Pin)
- 10 BS3
C872
(FL803 12Pin)
- 11 BS4
C874
(FL803 14Pin)

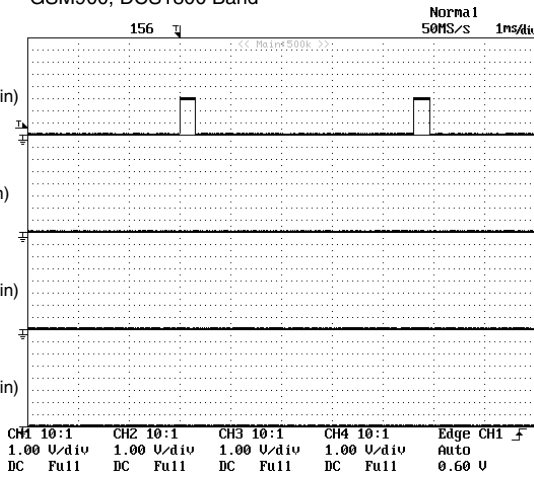

RF Test Tool
Rx test
PCS1900 Band

- 8 BS1
C870
(FL803 10Pin)
- 9 BS2
C871
(FL803 6Pin)
- 10 BS3
C872
(FL803 12Pin)
- 11 BS4
C874
(FL803 14Pin)

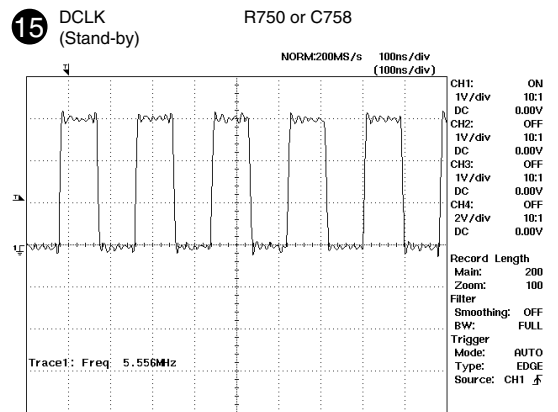
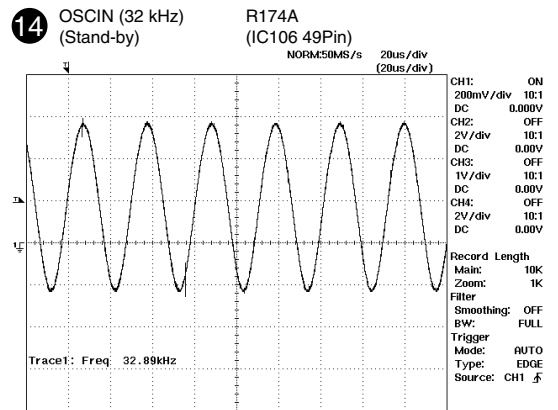
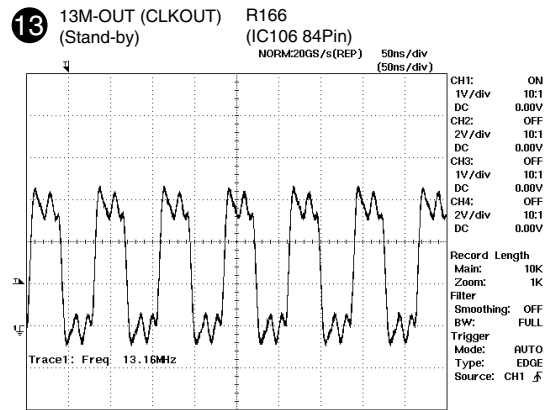
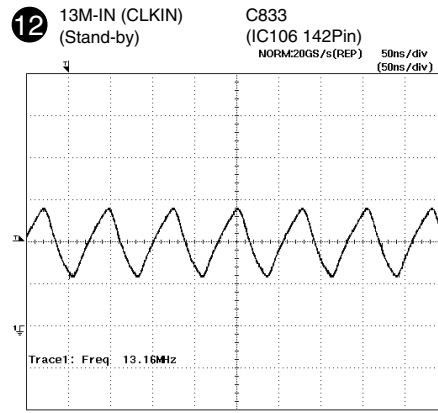
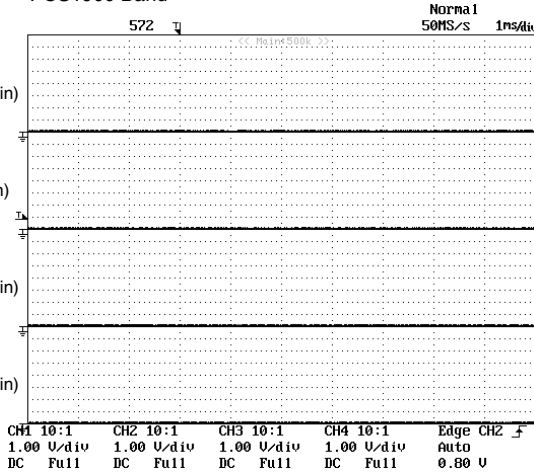

16 VSYNC (Stand-by)

C760

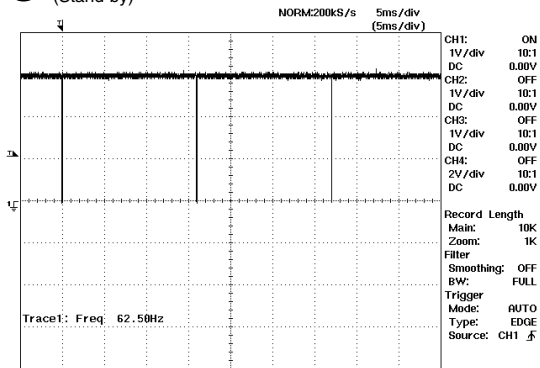

17 SUBFLM (Stand-by)

L711 1Pin

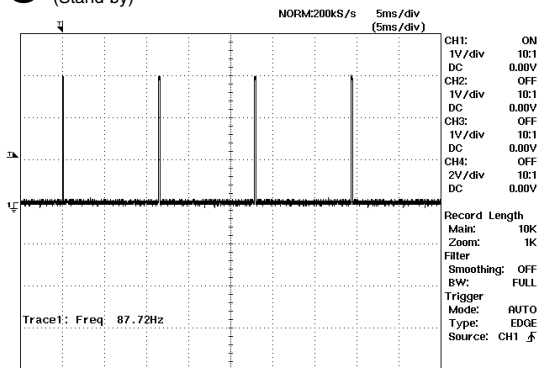

18 TCXOEN (Stand-by)

IC804 1Pin

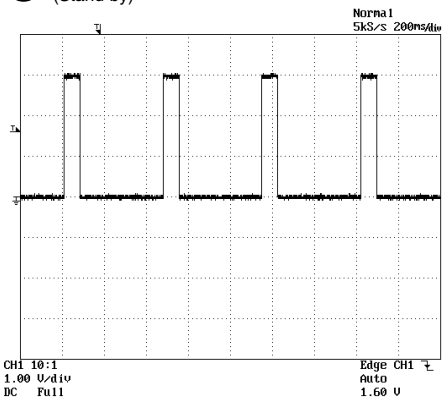

[4] Schematic diagram/Wiring side of P.W.Board

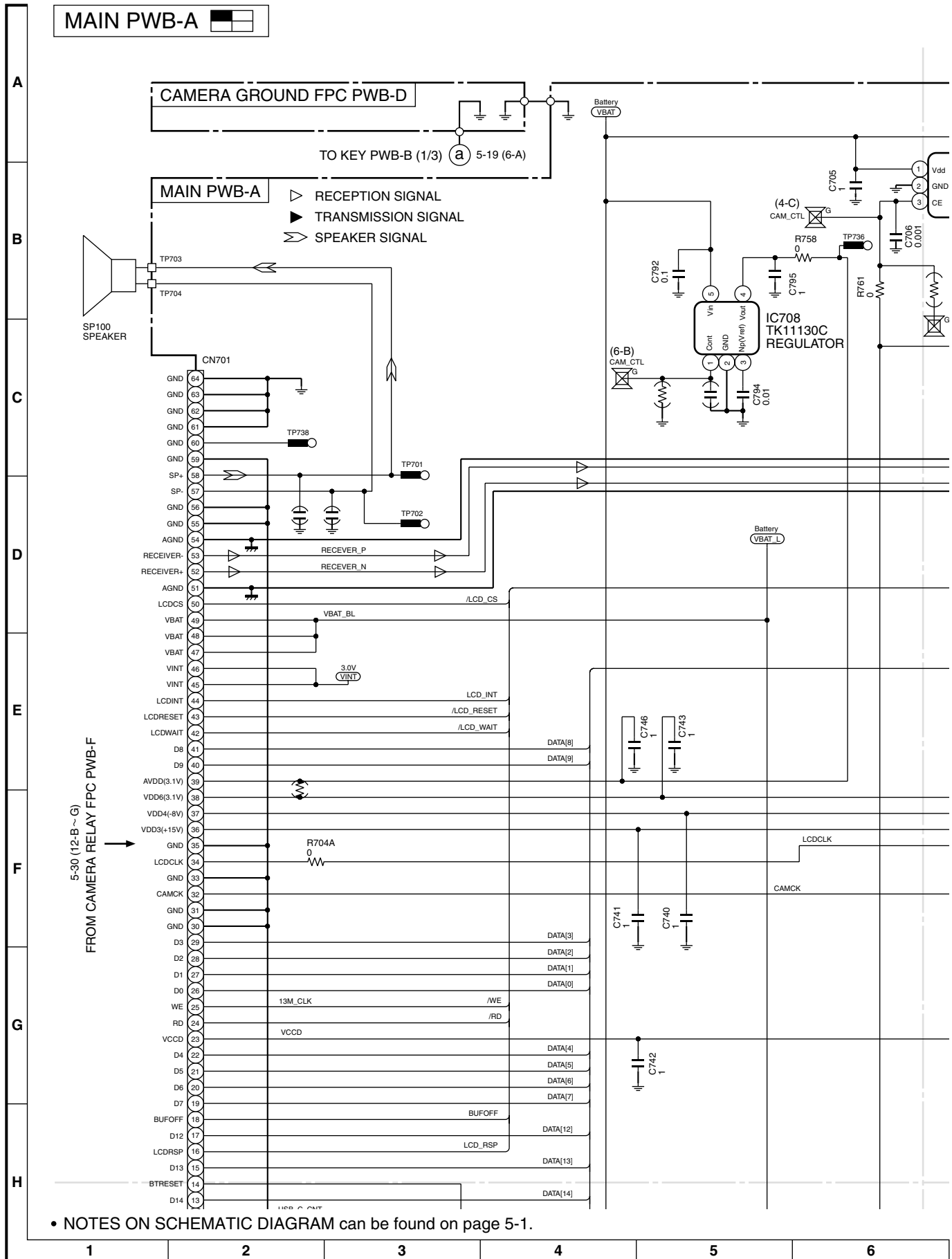
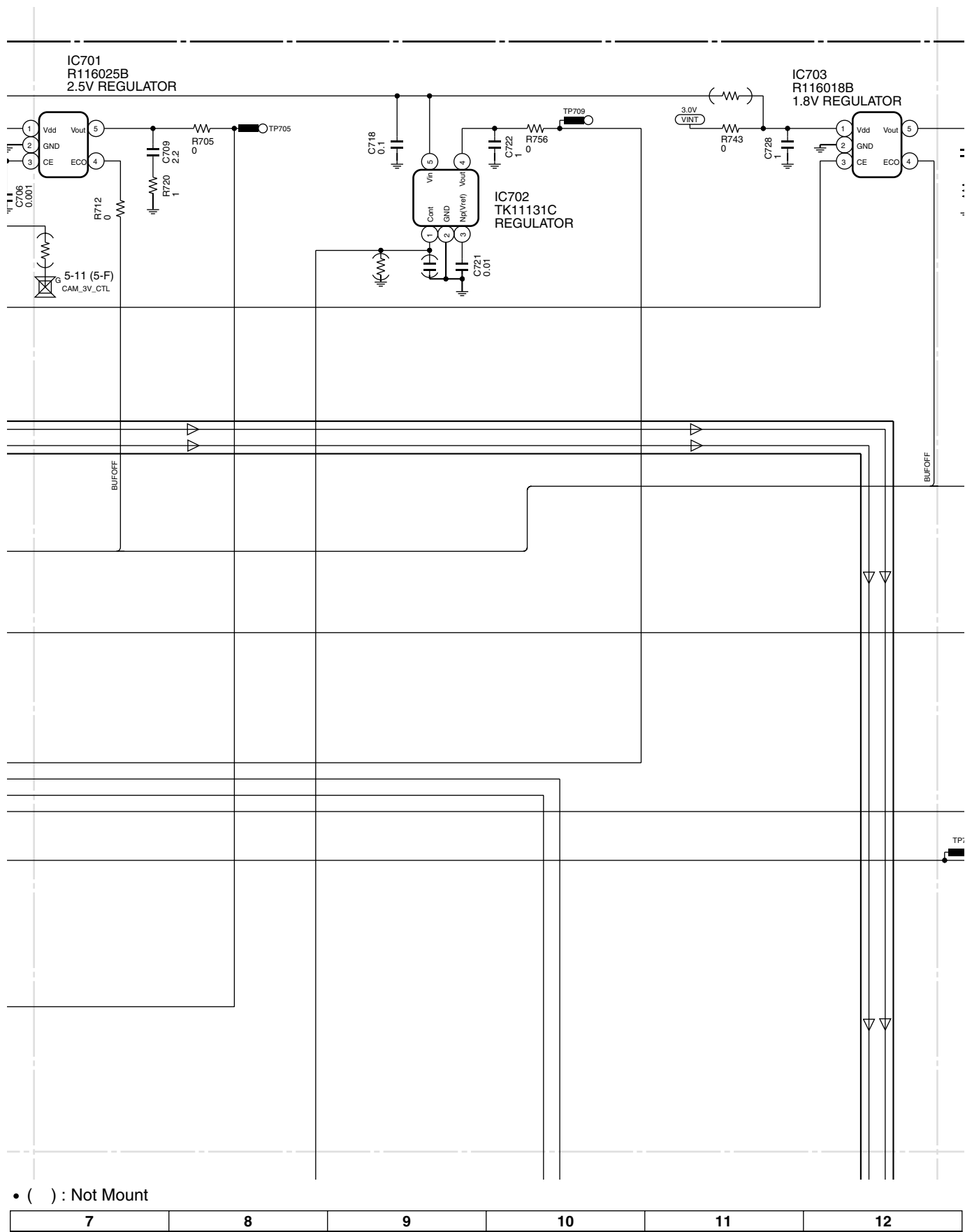

Figure 1 SCHEMATIC DIAGRAM (1/22)



• () : Not Mount

7	8	9	10	11	12
---	---	---	----	----	----

Figure 2 SCHEMATIC DIAGRAM (2/22)

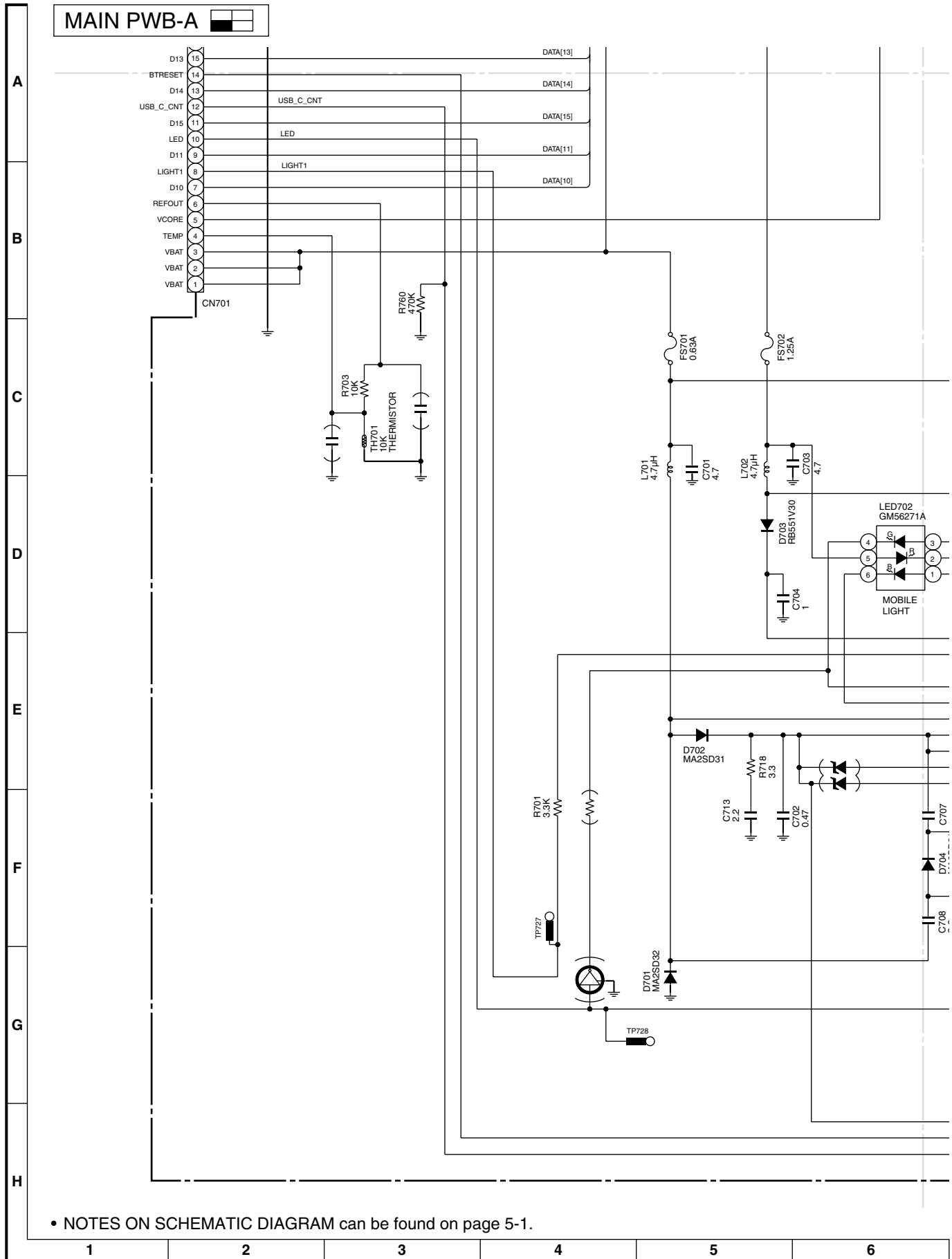
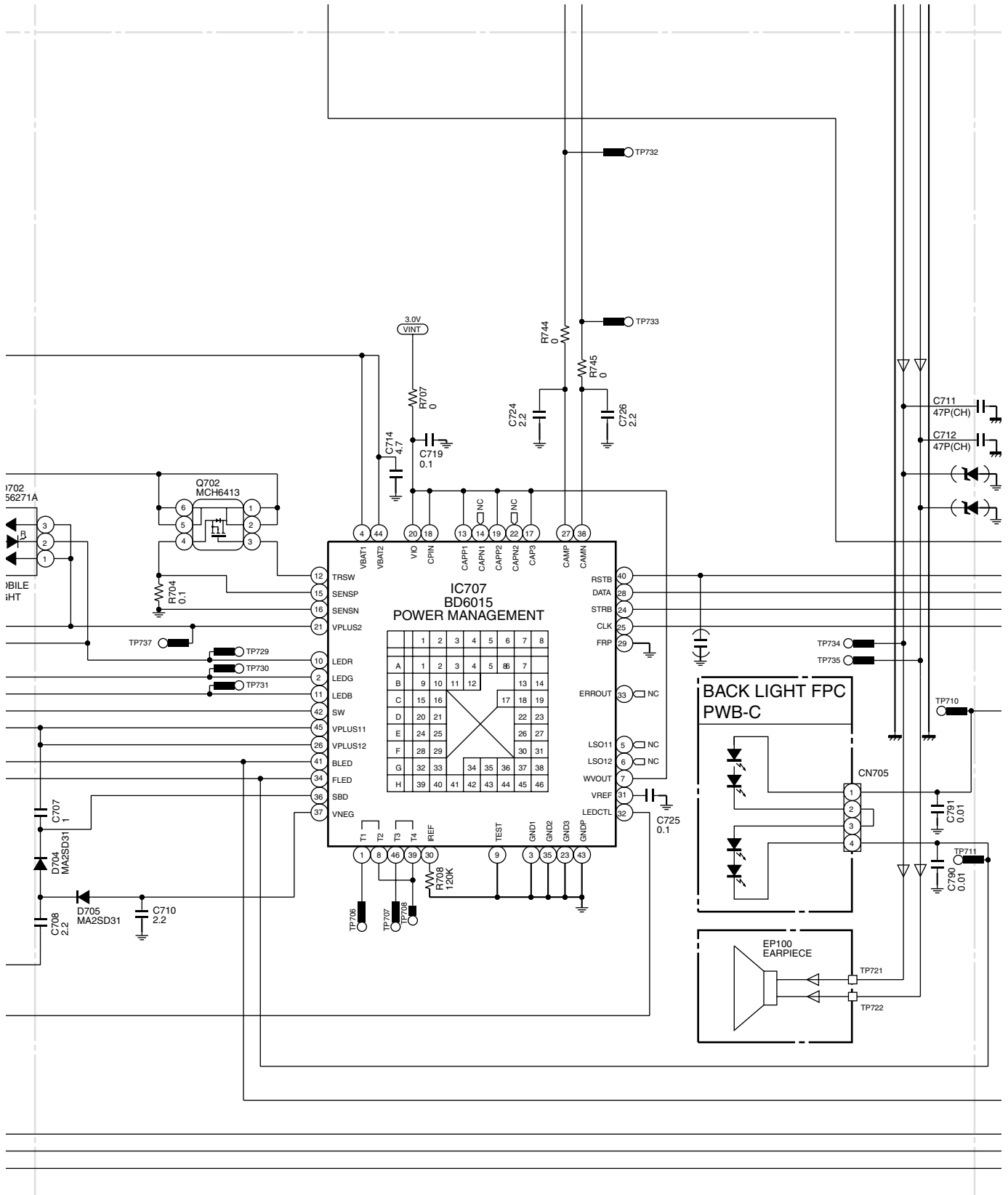

Figure 3 SCHEMATIC DIAGRAM (3/22)



• () : Not Mount

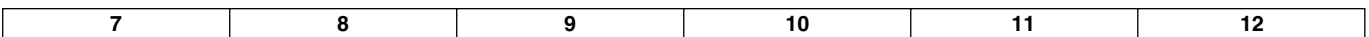

Figure 4 SCHEMATIC DIAGRAM (4/22)

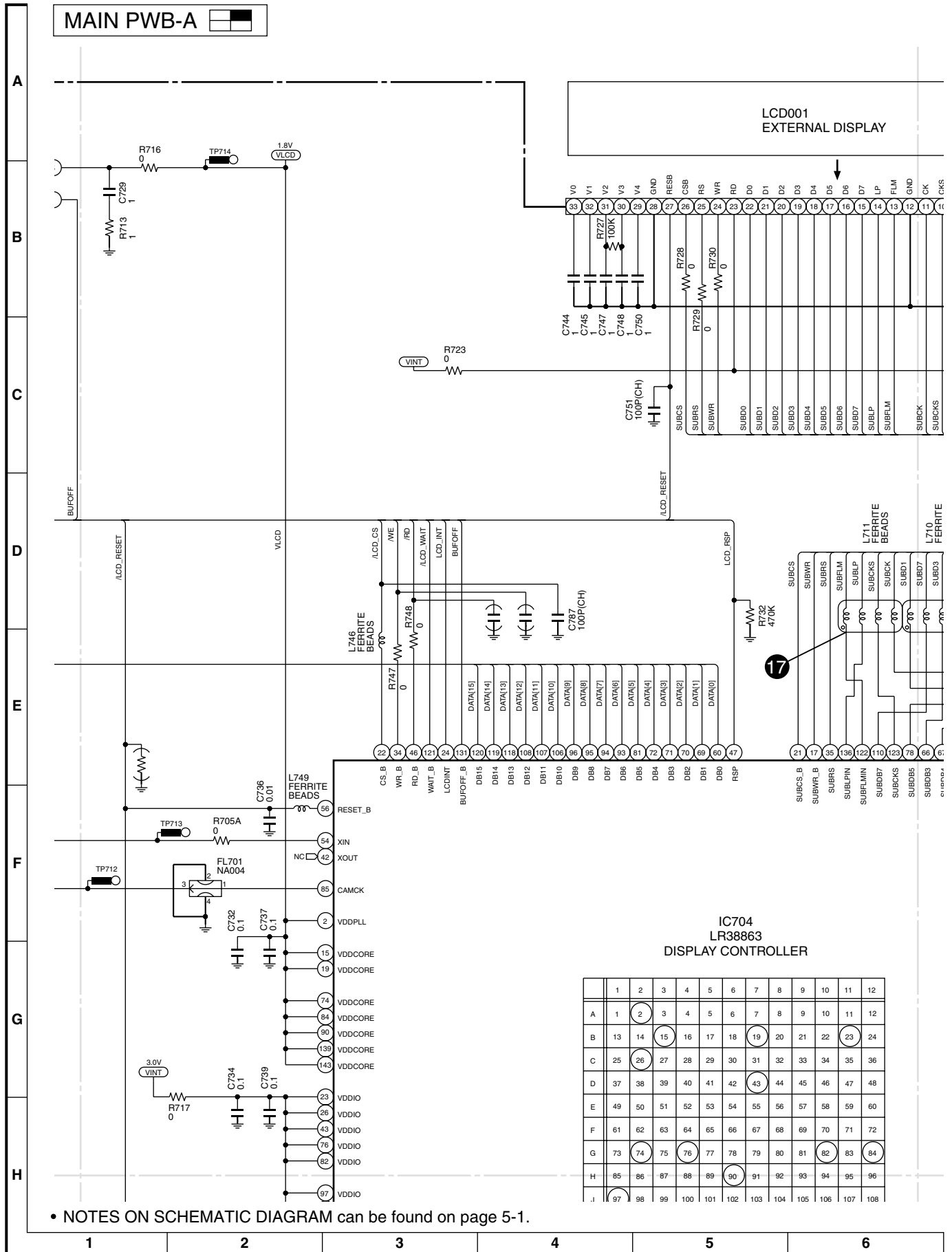

Figure 5 SCHEMATIC DIAGRAM (5/22)

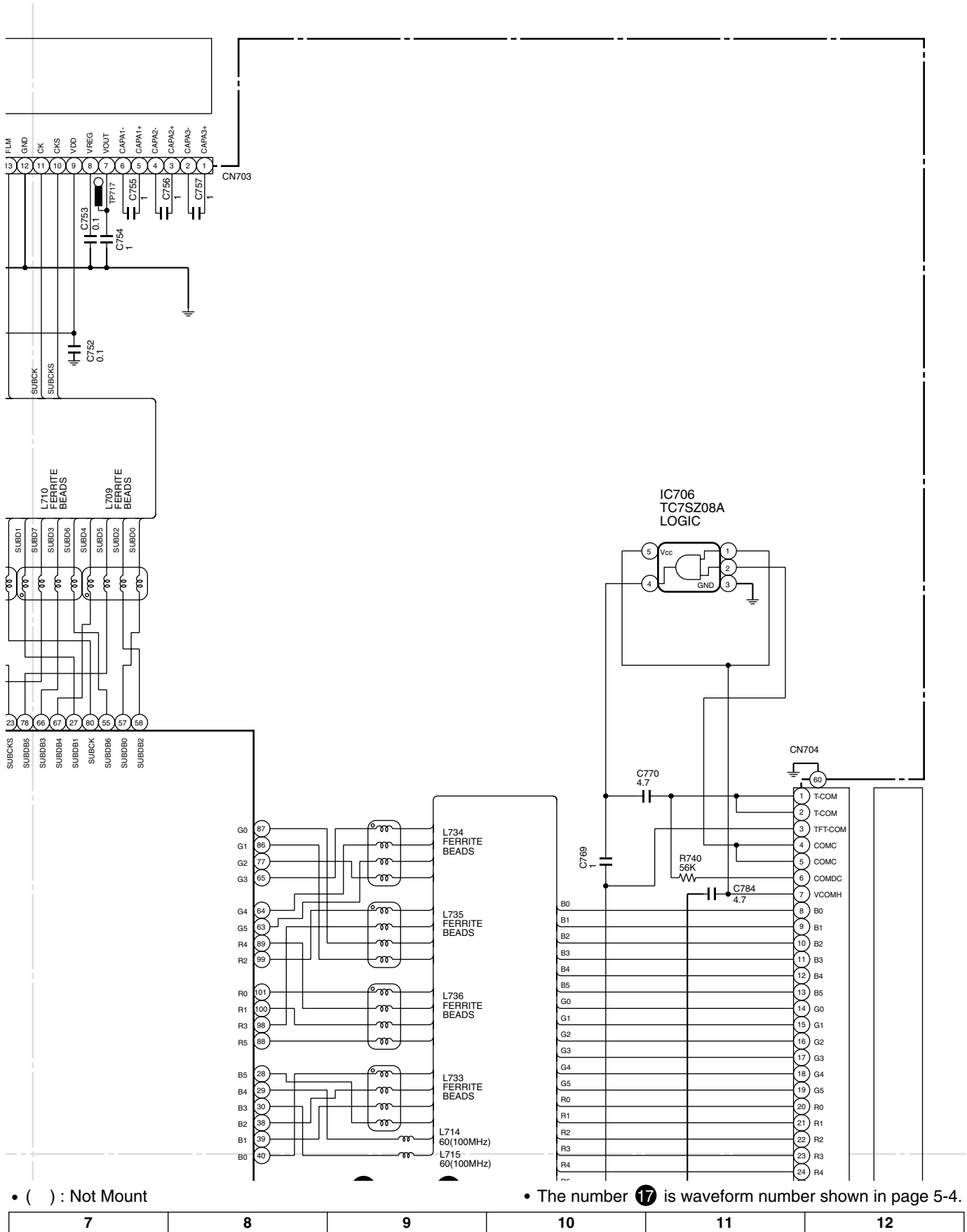

Figure 6 SCHEMATIC DIAGRAM (6/22)

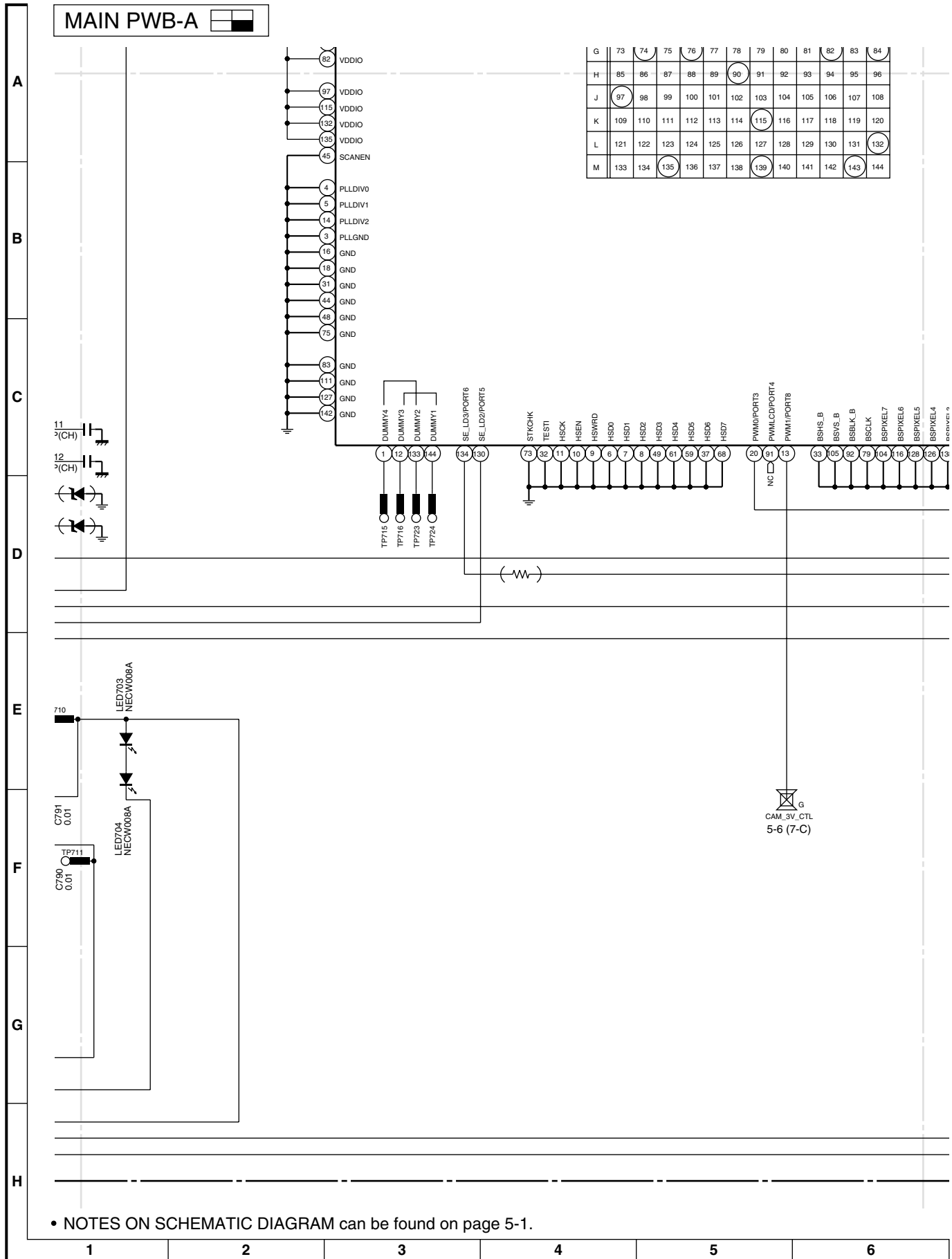
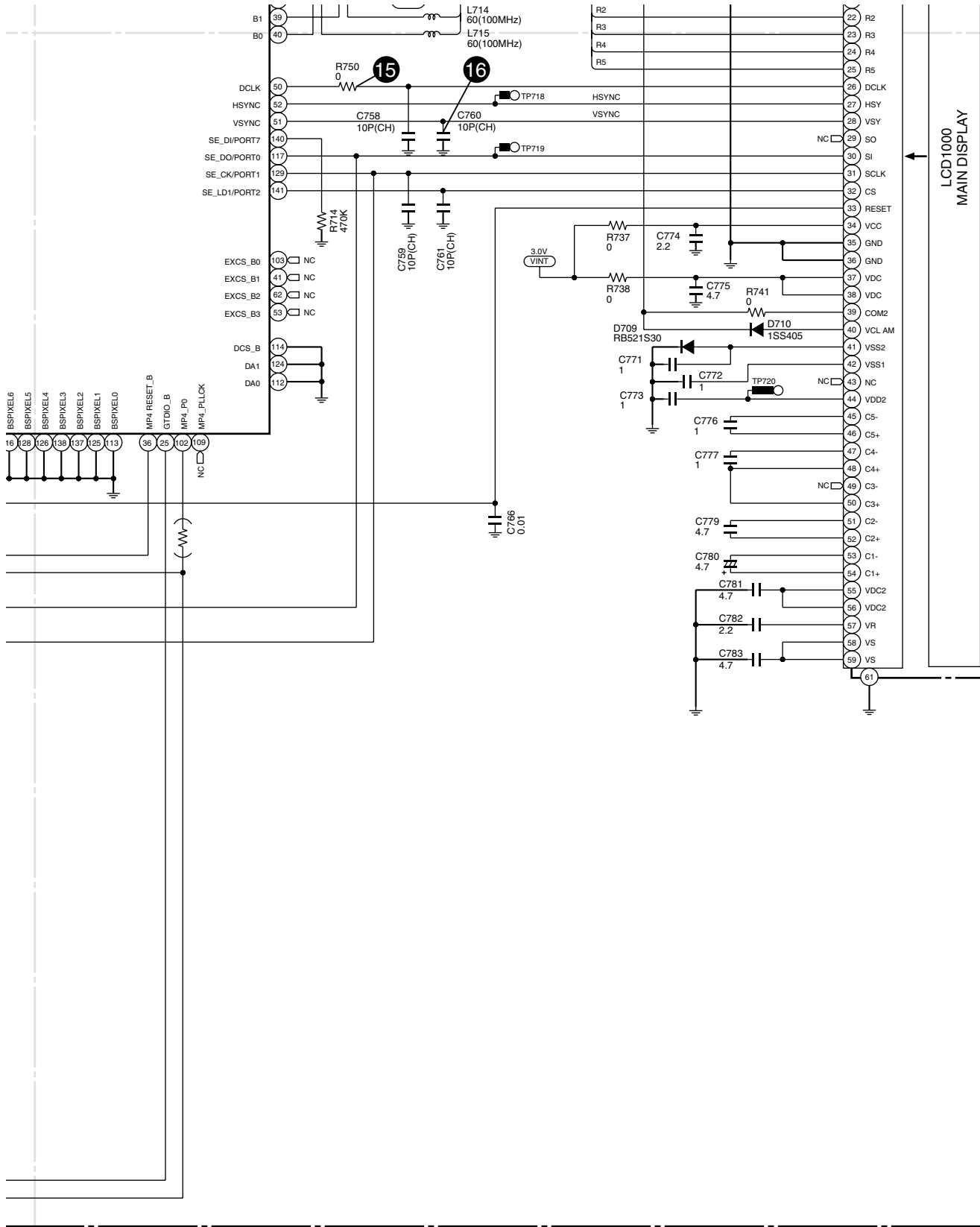

Figure 7 SCHEMATIC DIAGRAM (7/22)



• () : Not Mount

• The numbers 15, 16 are waveform numbers shown in pages 5-3, 5-4.

7	8	9	10	11	12
---	---	---	----	----	----

Figure 8 SCHEMATIC DIAGRAM (8/22)

MAIN PWB-A (FRONT SIDE)

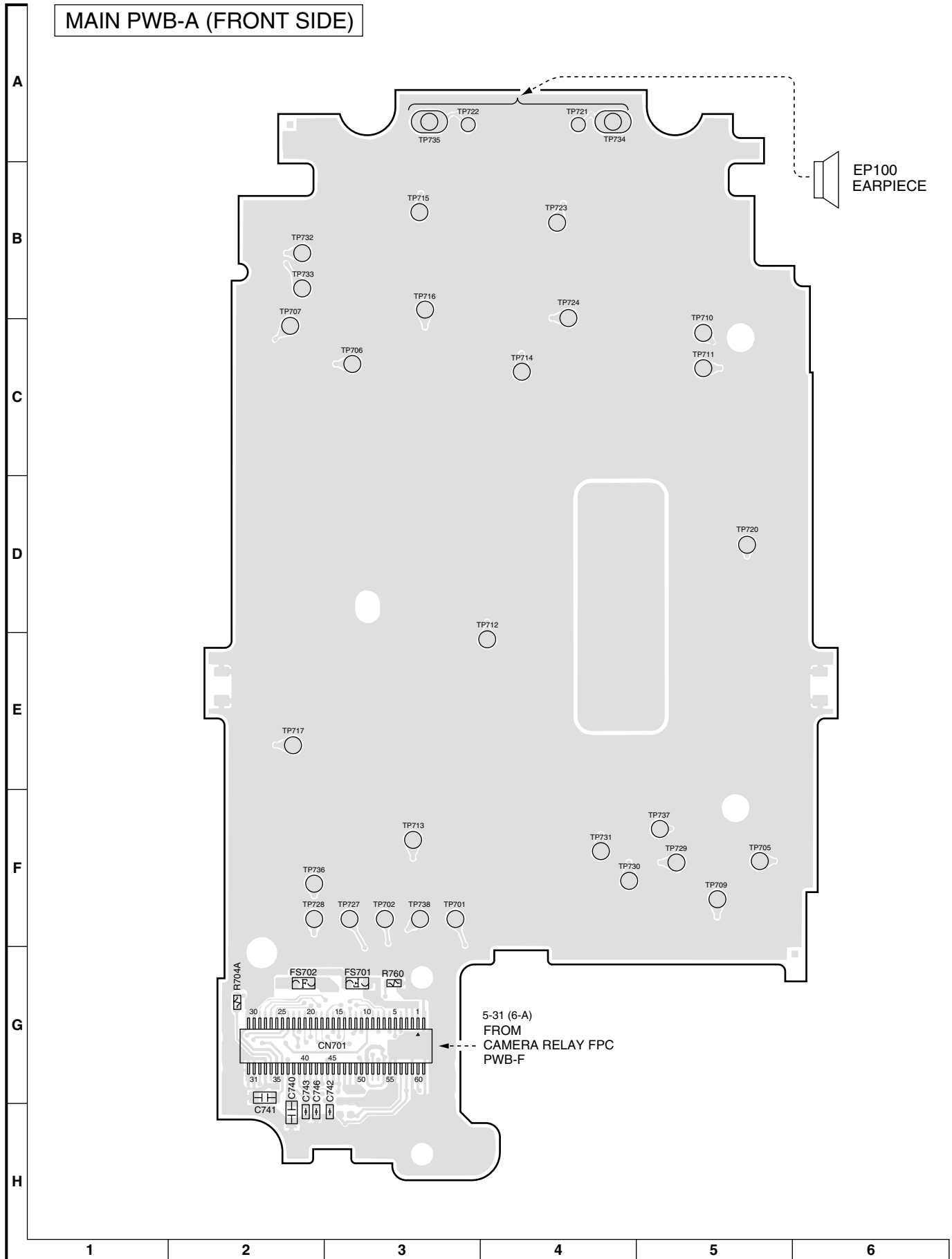
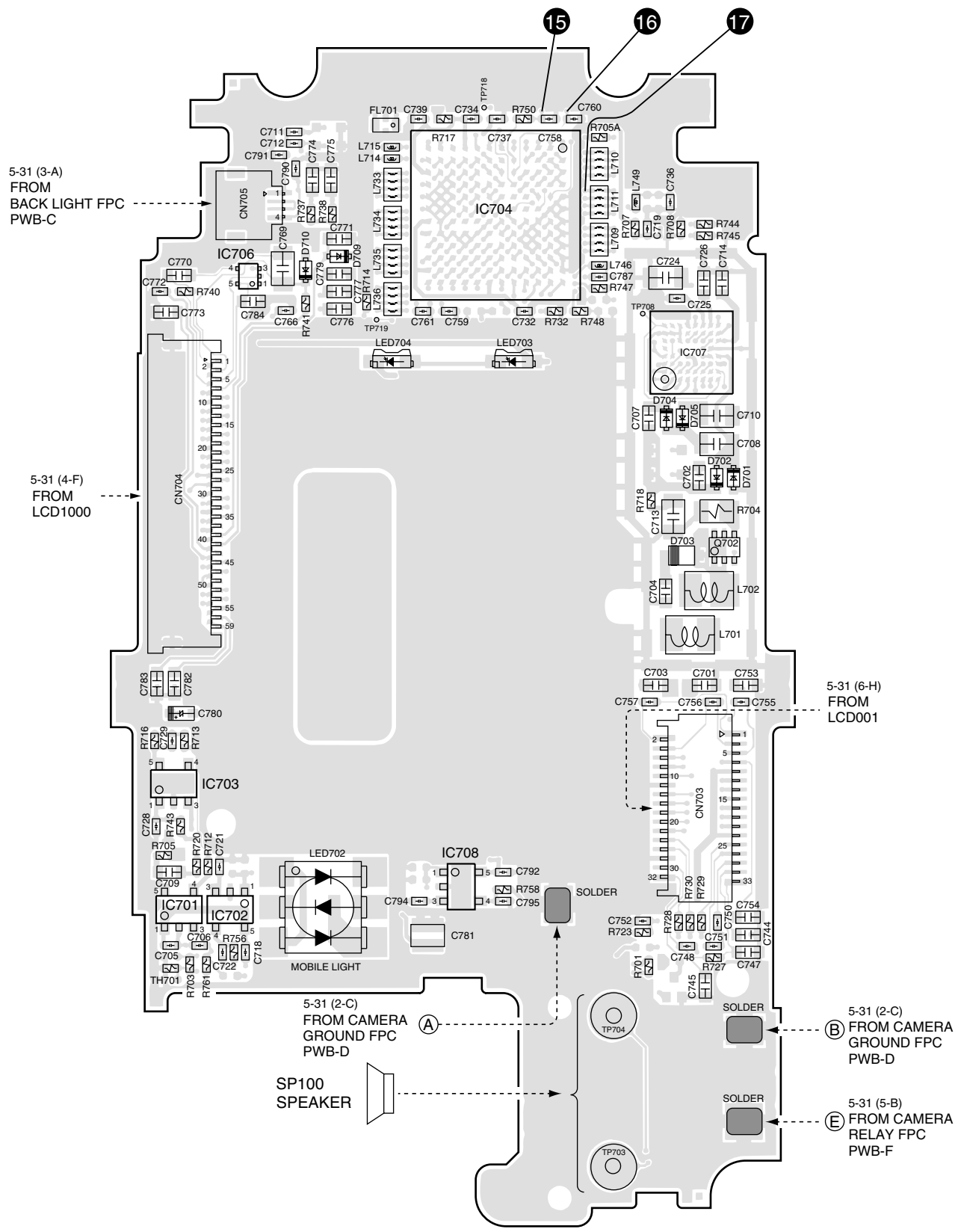

Figure 9 WIRING SIDE P.W.BOARD (1/5)

MAIN PWB-A (REAR SIDE)



• The numbers 15 to 17 are waveform numbers shown in pages 5-3, 5-4.

7	8	9	10	11	12
---	---	---	----	----	----

Figure 10 WIRING SIDE P.W.BOARD (2/5)

KEY PWB-B (1/3)

A
B
C
D
E
F
G
H

KEY PWB-B (1/3)

- ▷ RECEPTION SIGNAL
- ▶ TRANSMISSION SIGNAL
- SPEAKER SIGNAL

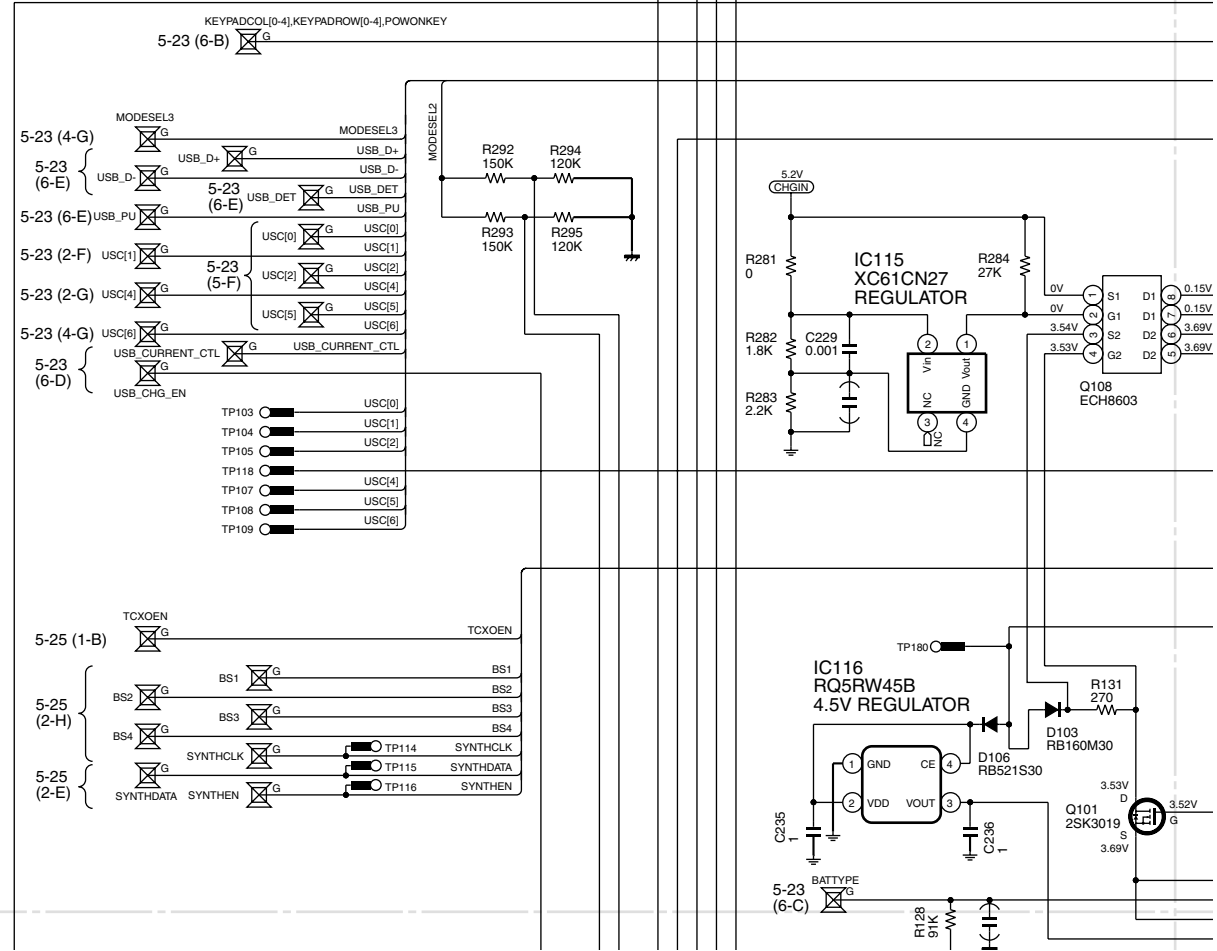

• NOTES ON SCHEMATIC DIAGRAM can be found on page 5-1.

Figure 11 SCHEMATIC DIAGRAM (9/22)

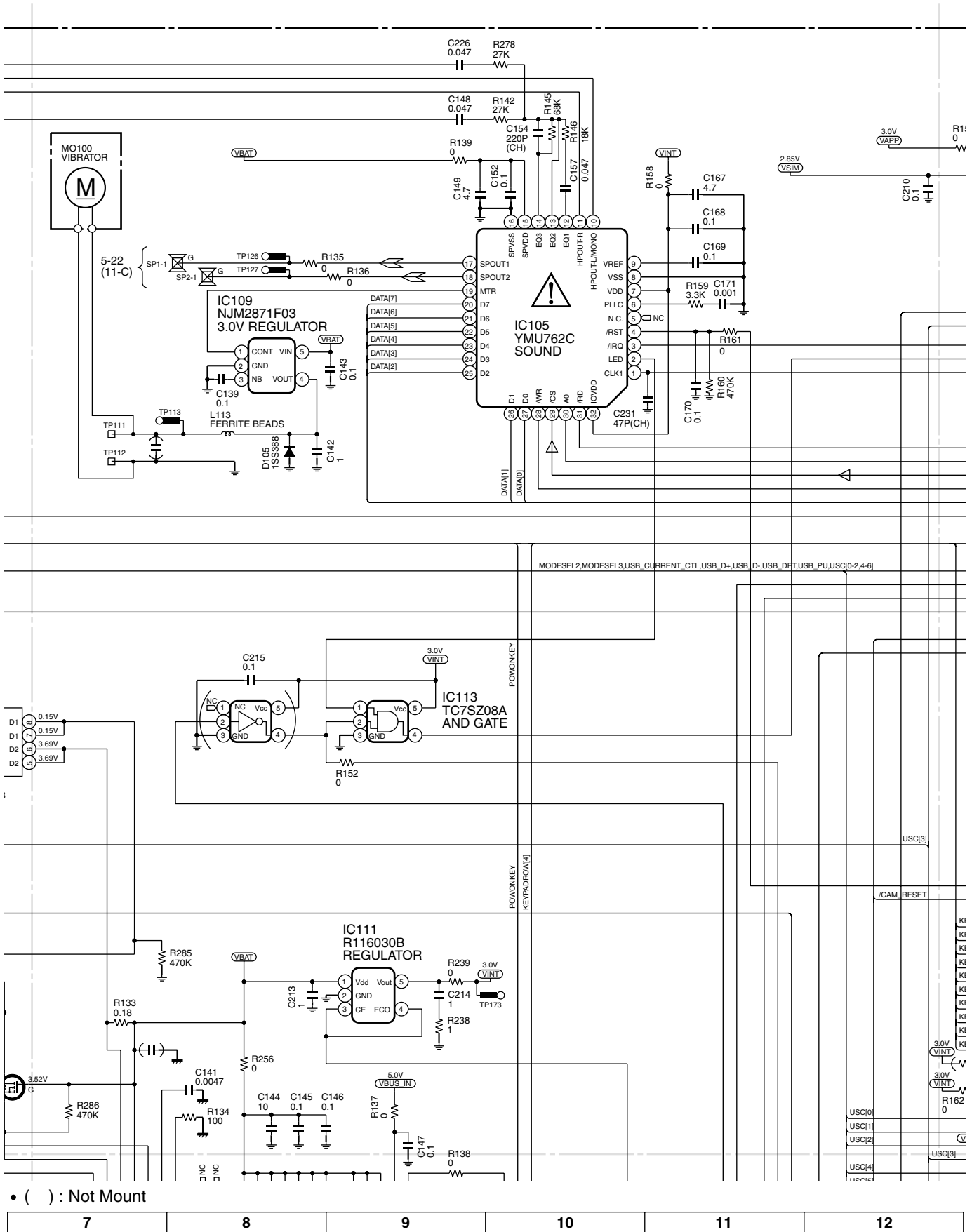
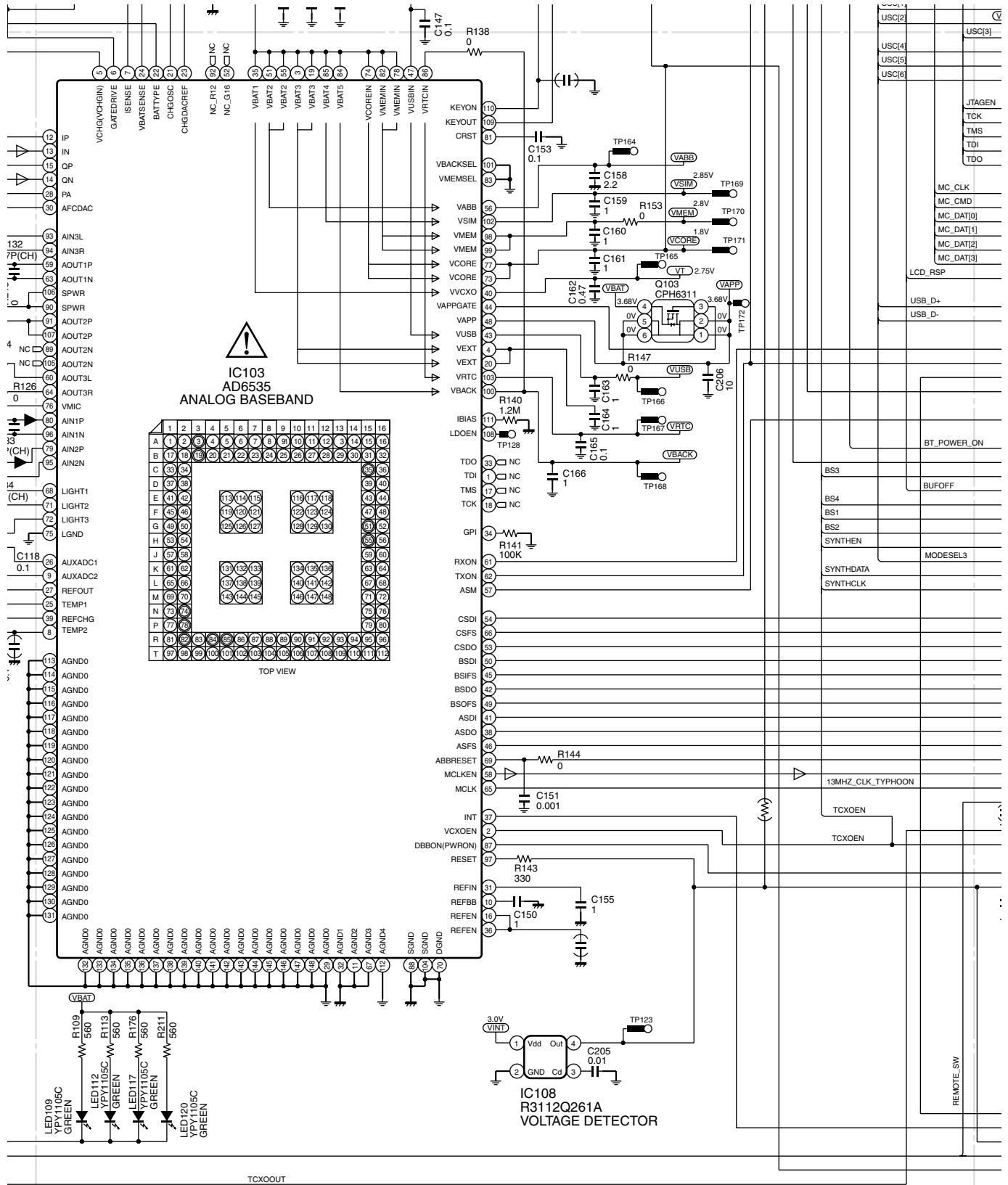

Figure 12 SCHEMATIC DIAGRAM (10/22)



• () : Not Mount

7	8	9	10	11	12
---	---	---	----	----	----

Figure 14 SCHEMATIC DIAGRAM (12/22)

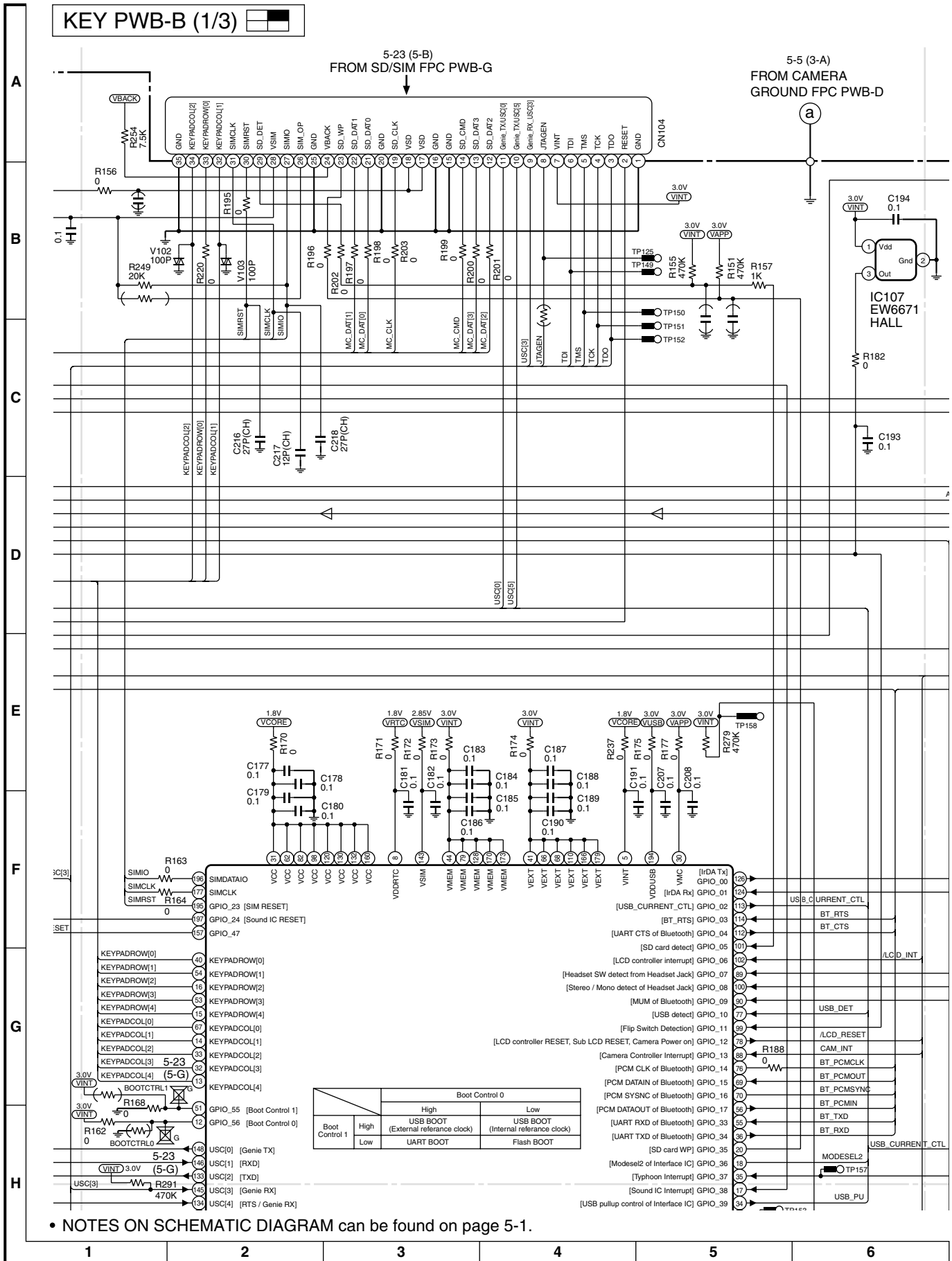

Figure 15 SCHEMATIC DIAGRAM (13/22)

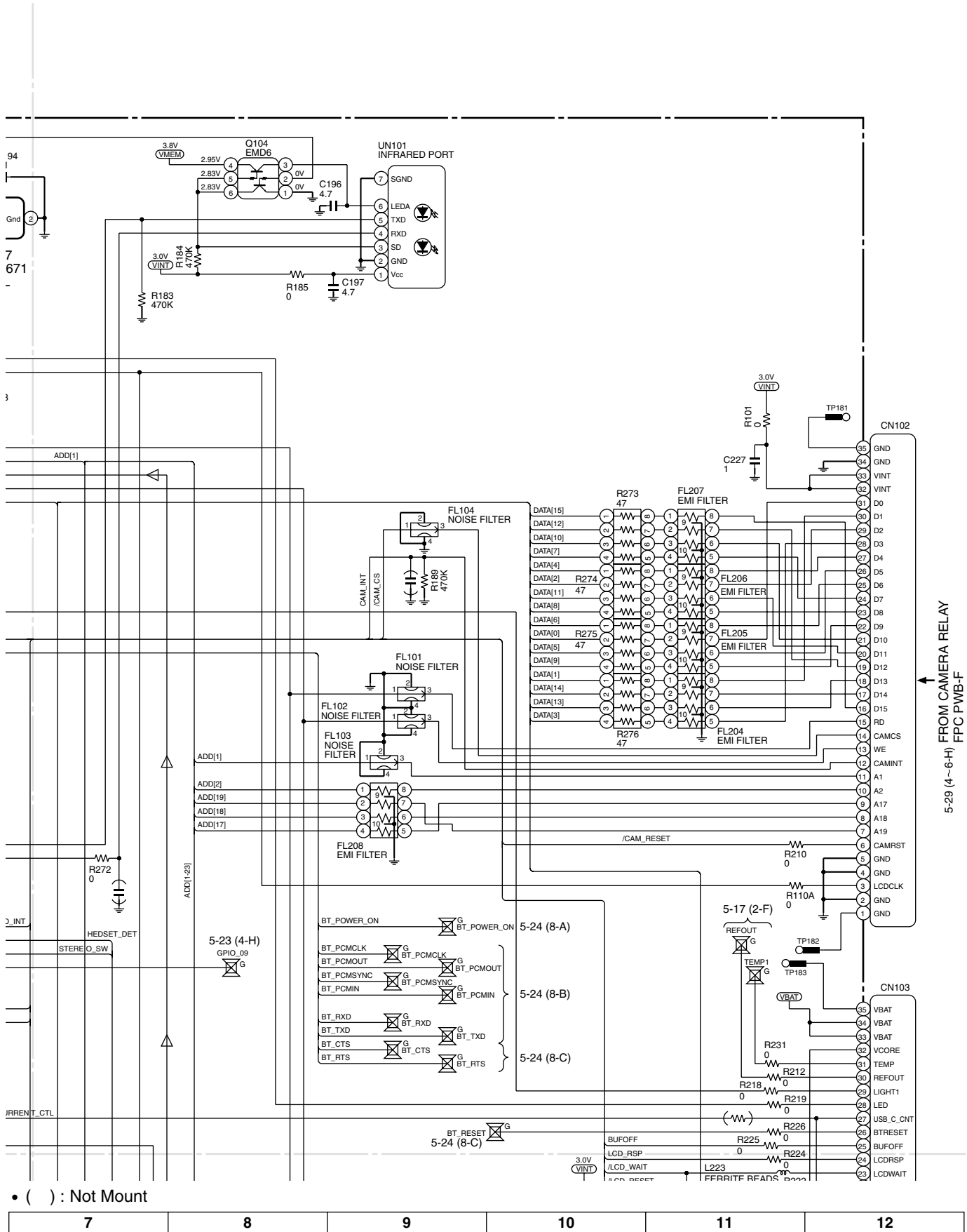
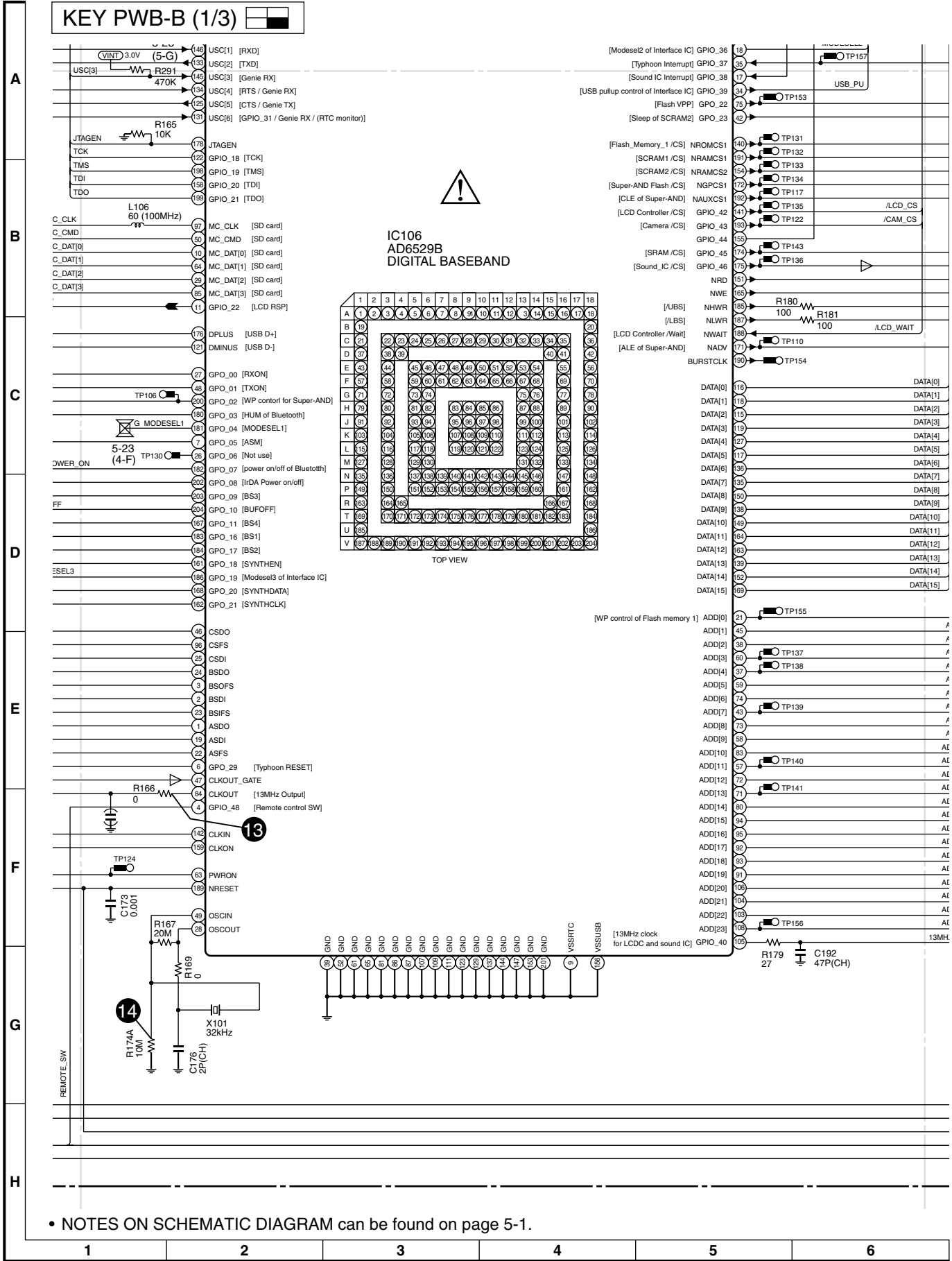

Figure 16 SCHEMATIC DIAGRAM (14/22)

KEY PWB-B (1/3)



• NOTES ON SCHEMATIC DIAGRAM can be found on page 5-1.

Figure 17 SCHEMATIC DIAGRAM (15/22)

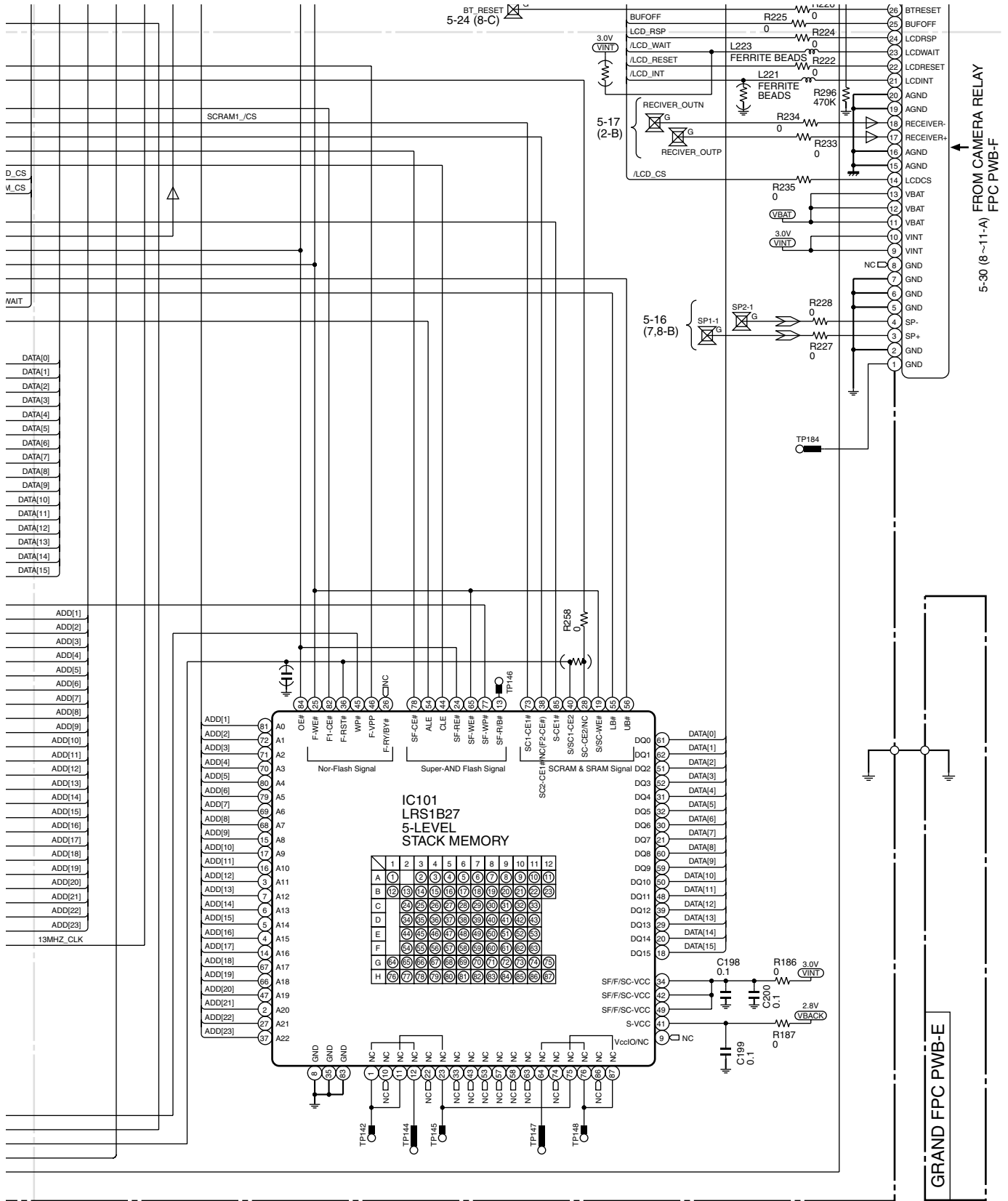

• () : Not Mount

• The numbers 13, 14 are waveform numbers shown in page 5-3.

7	8	9	10	11	12
---	---	---	----	----	----

Figure 18 SCHEMATIC DIAGRAM (16/22)

KEY PWB-B (2/3)

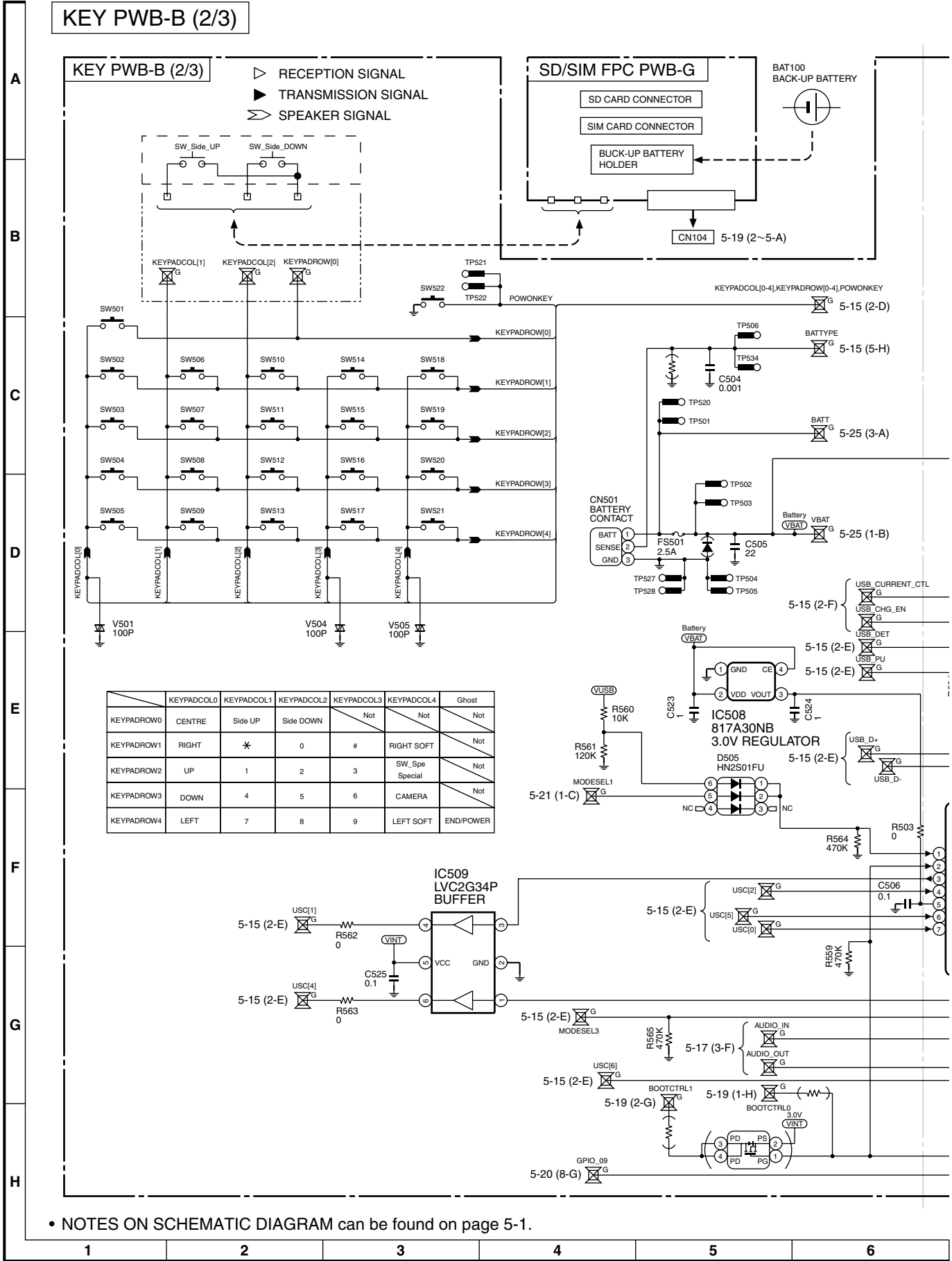

• NOTES ON SCHEMATIC DIAGRAM can be found on page 5-1.

Figure 19 SCHEMATIC DIAGRAM (17/22)

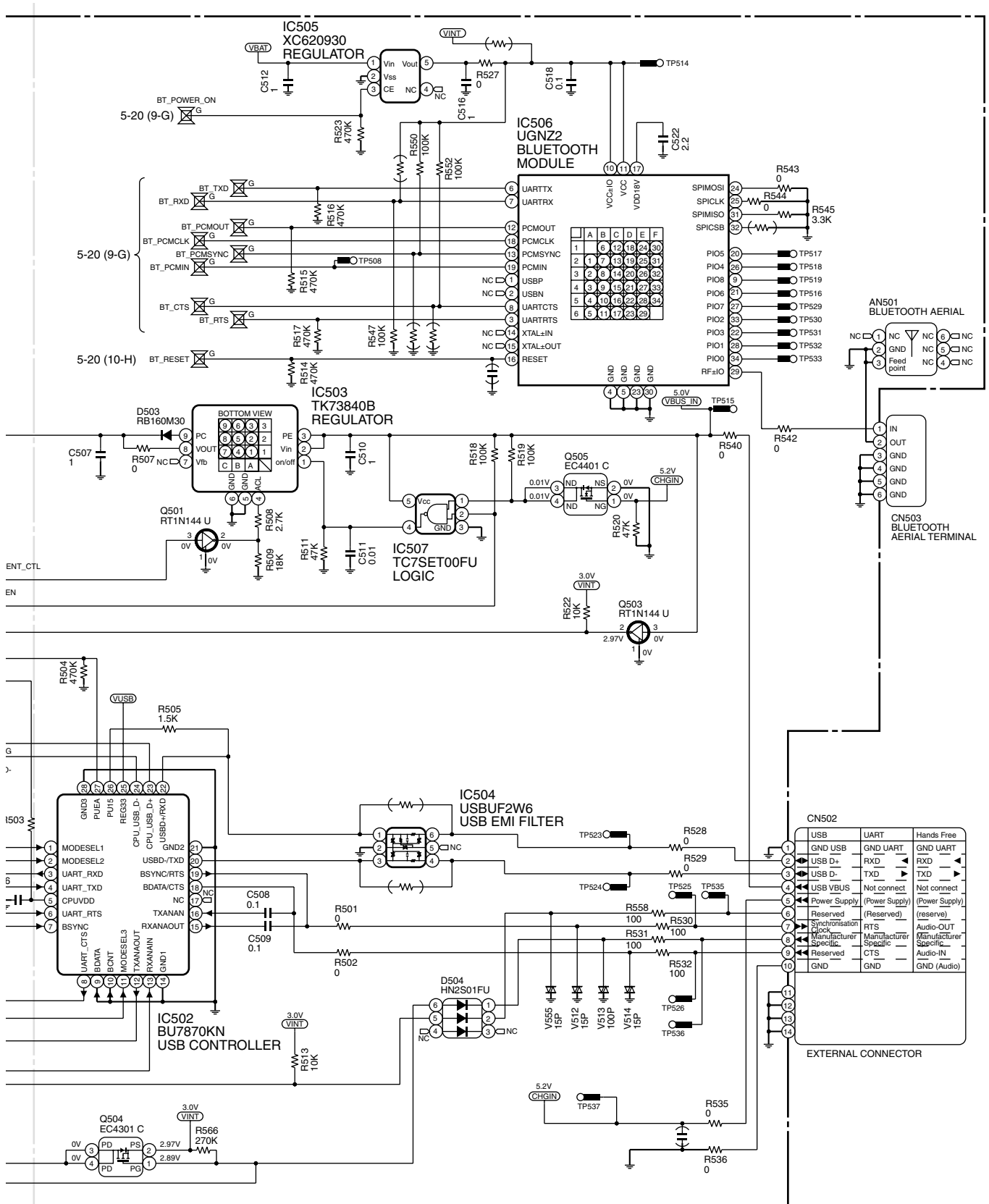

• () : Not Mount

7	8	9	10	11	12
---	---	---	----	----	----

Figure 20 SCHEMATIC DIAGRAM (18/22)

KEY PWB-B (3/3)

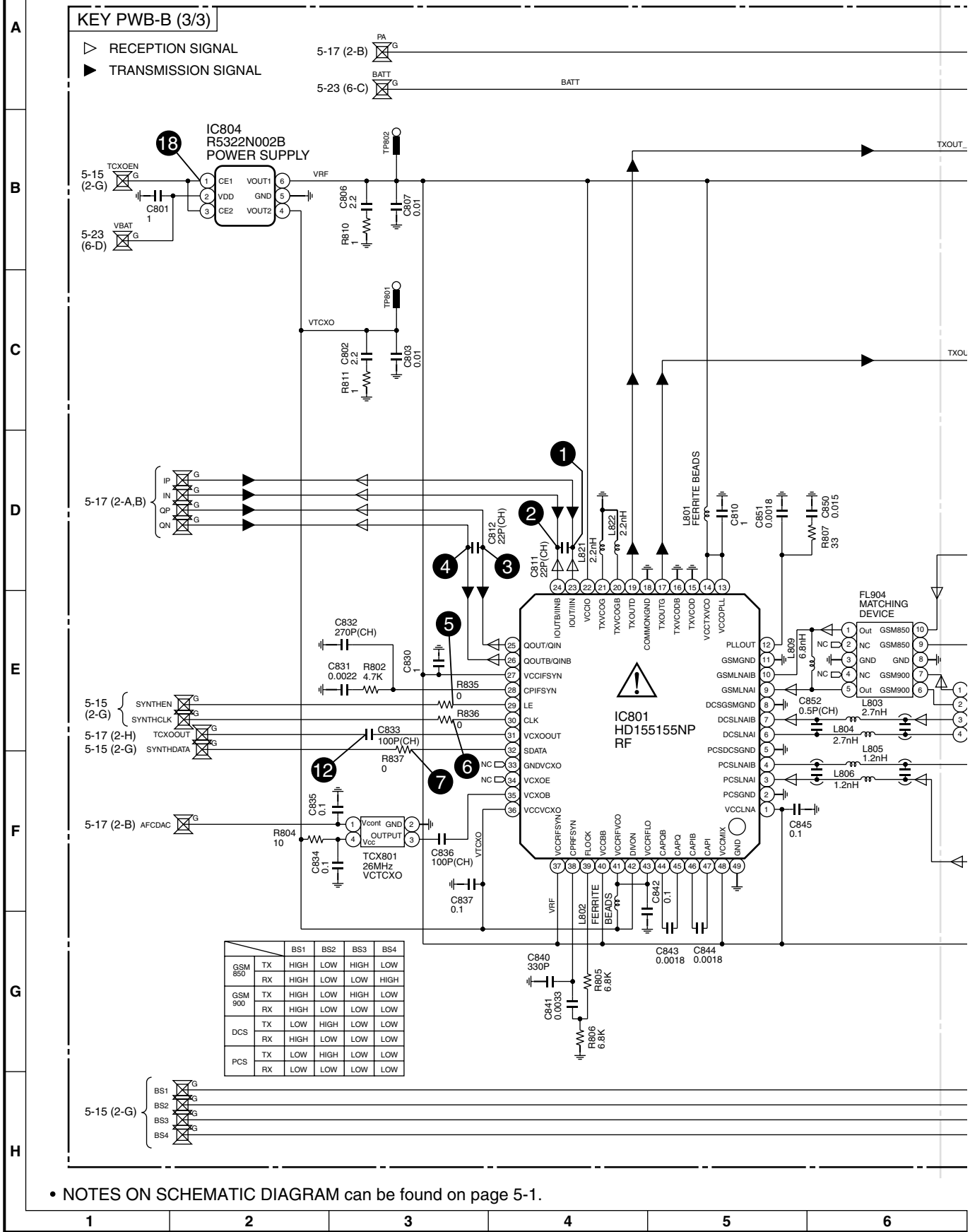

• NOTES ON SCHEMATIC DIAGRAM can be found on page 5-1.

Figure 21 SCHEMATIC DIAGRAM (19/22)

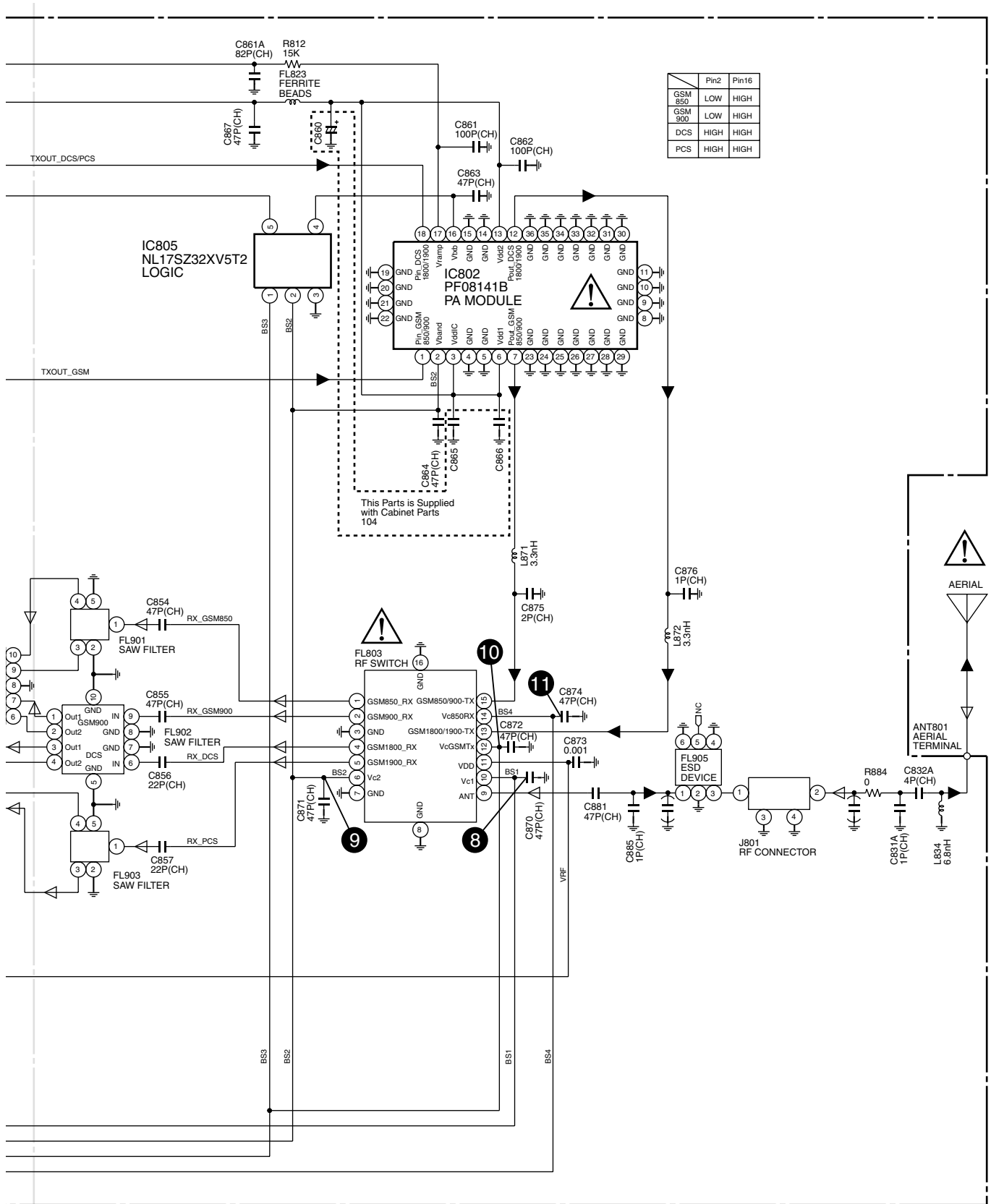

• () : Not Mount

• The numbers ① to ⑫ and ⑱ are waveform numbers shown in pages 5-2 to 5-4.

7	8	9	10	11	12
---	---	---	----	----	----

Figure 22 SCHEMATIC DIAGRAM (20/22)

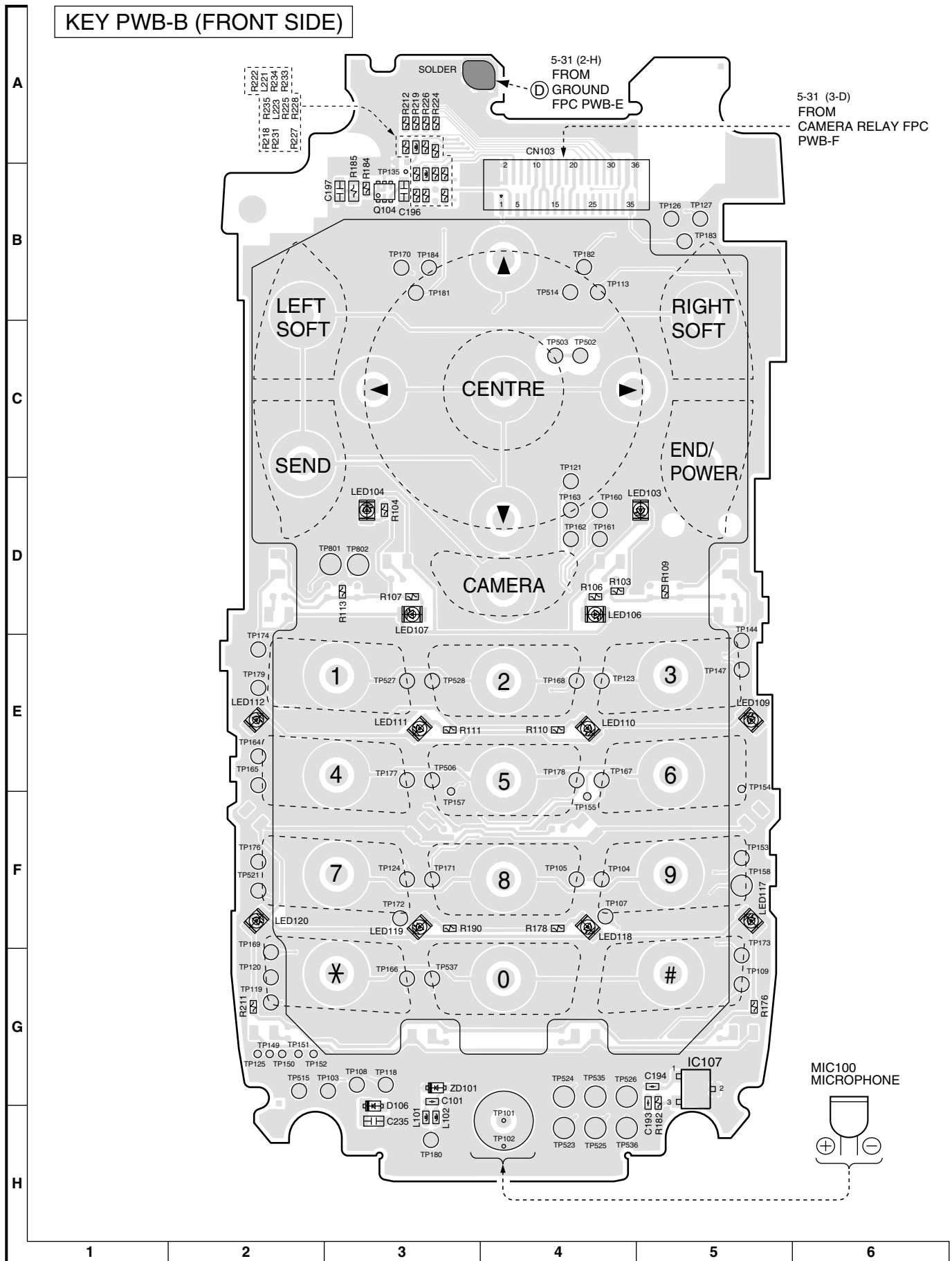
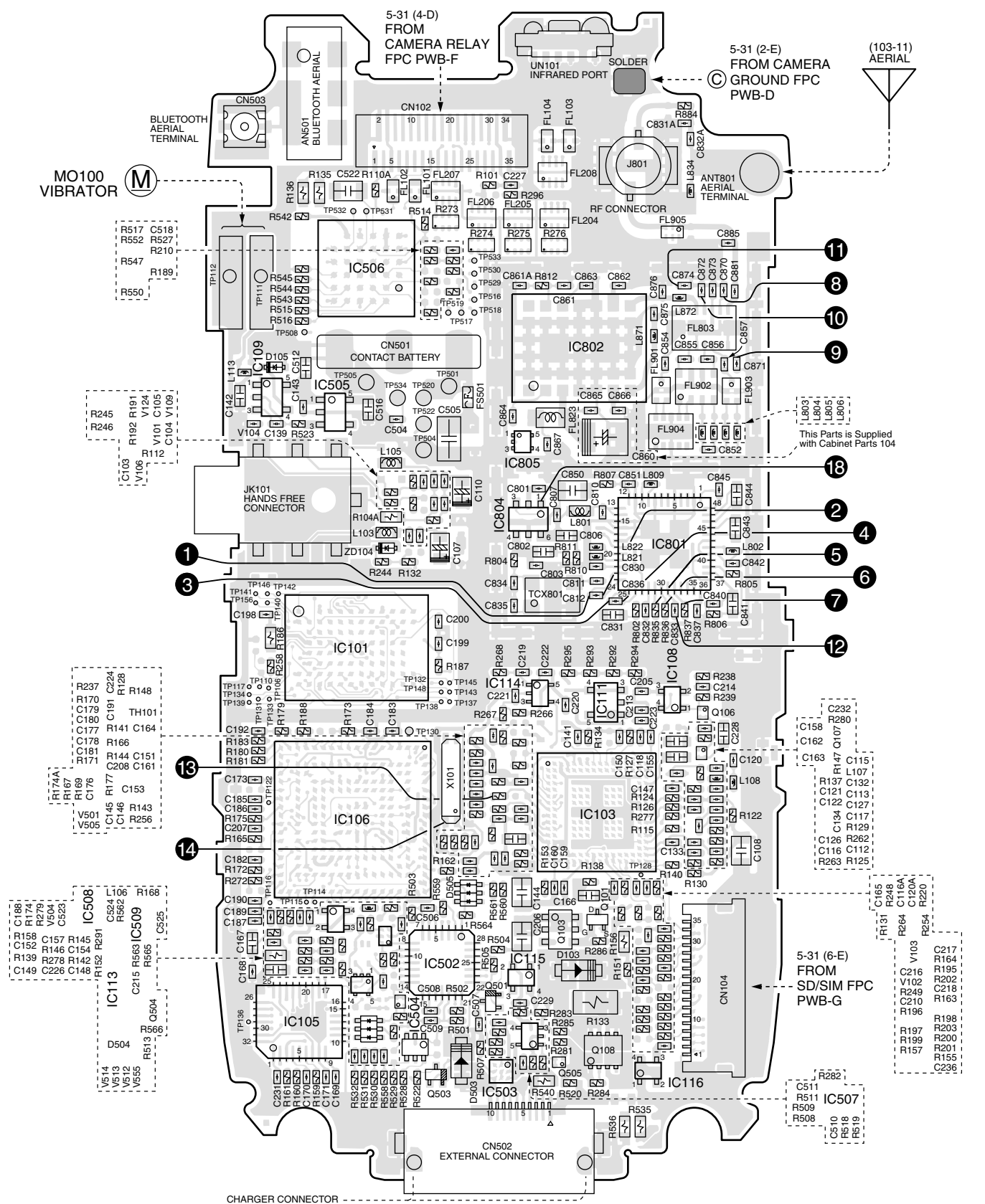

Figure 23 WIRING SIDE P.W.BOARD (3/5)

KEY PWB-B (REAR SIDE)



• The numbers 1 to 14 and 18 are waveform numbers shown in pages 5-2 to 5-4.

7	8	9	10	11	12
---	---	---	----	----	----

Figure 24 WIRING SIDE P.W.BOARD (4/5)

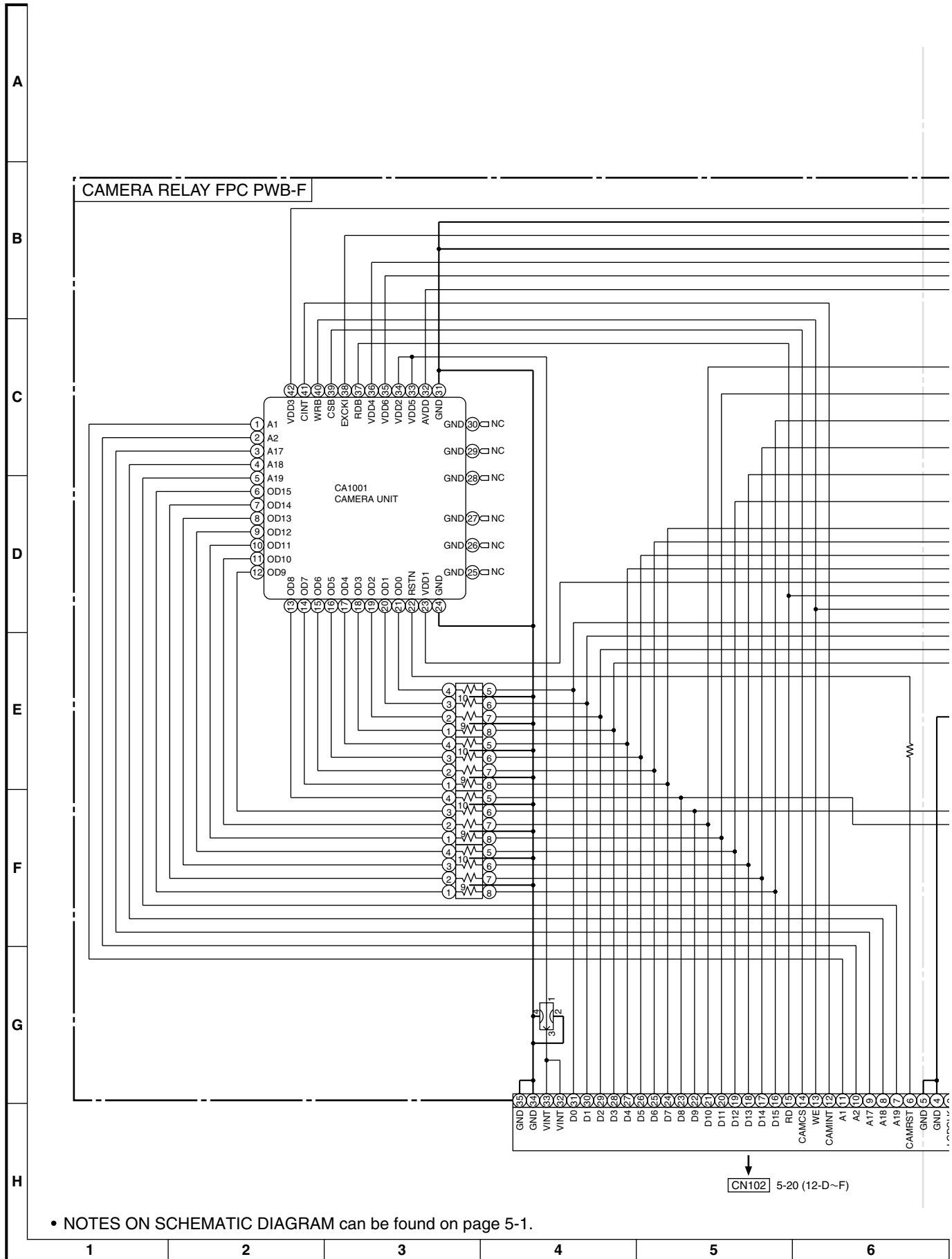

Figure 25 SCHEMATIC DIAGRAM (21/22)

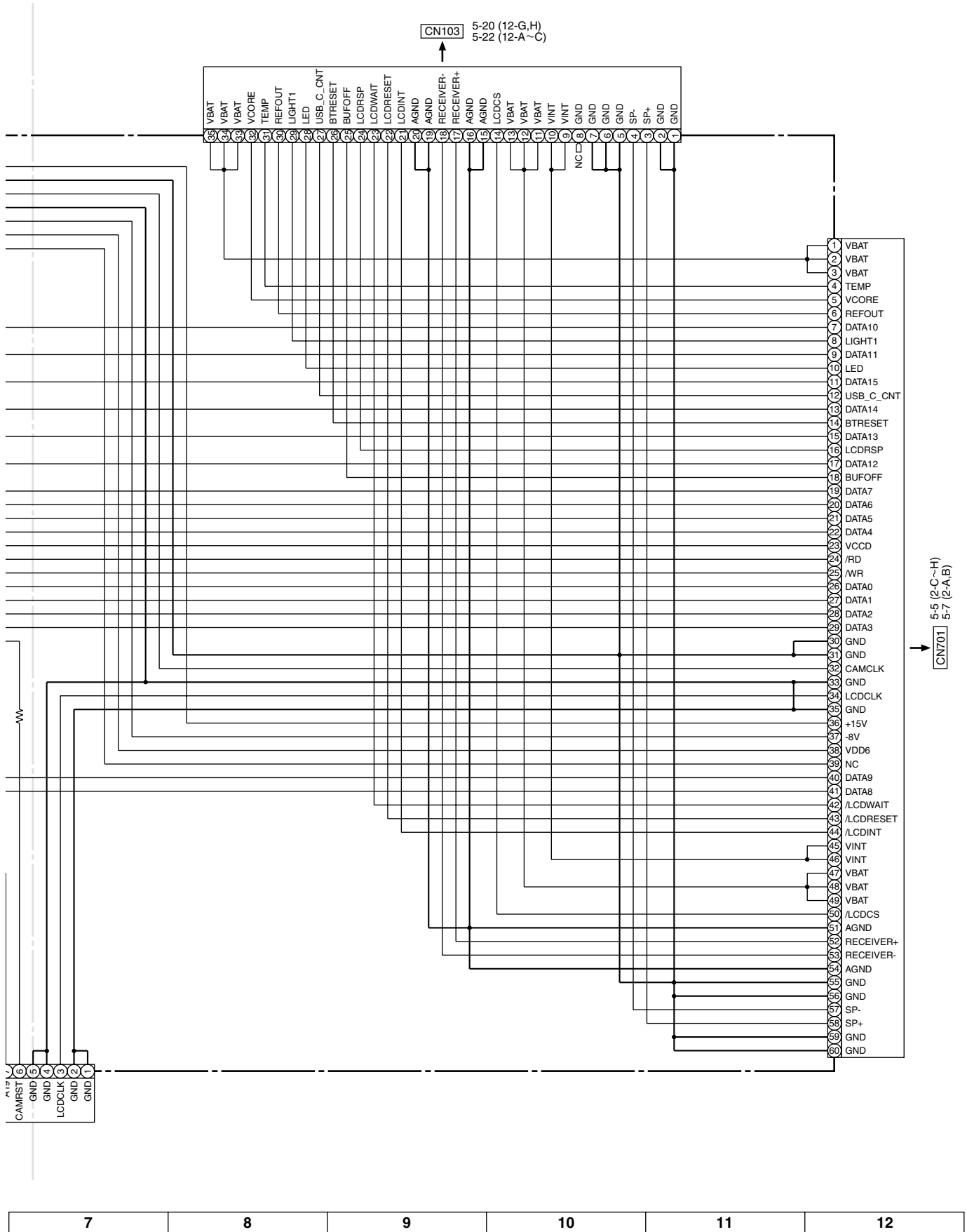

Figure 26 SCHEMATIC DIAGRAM (22/22)

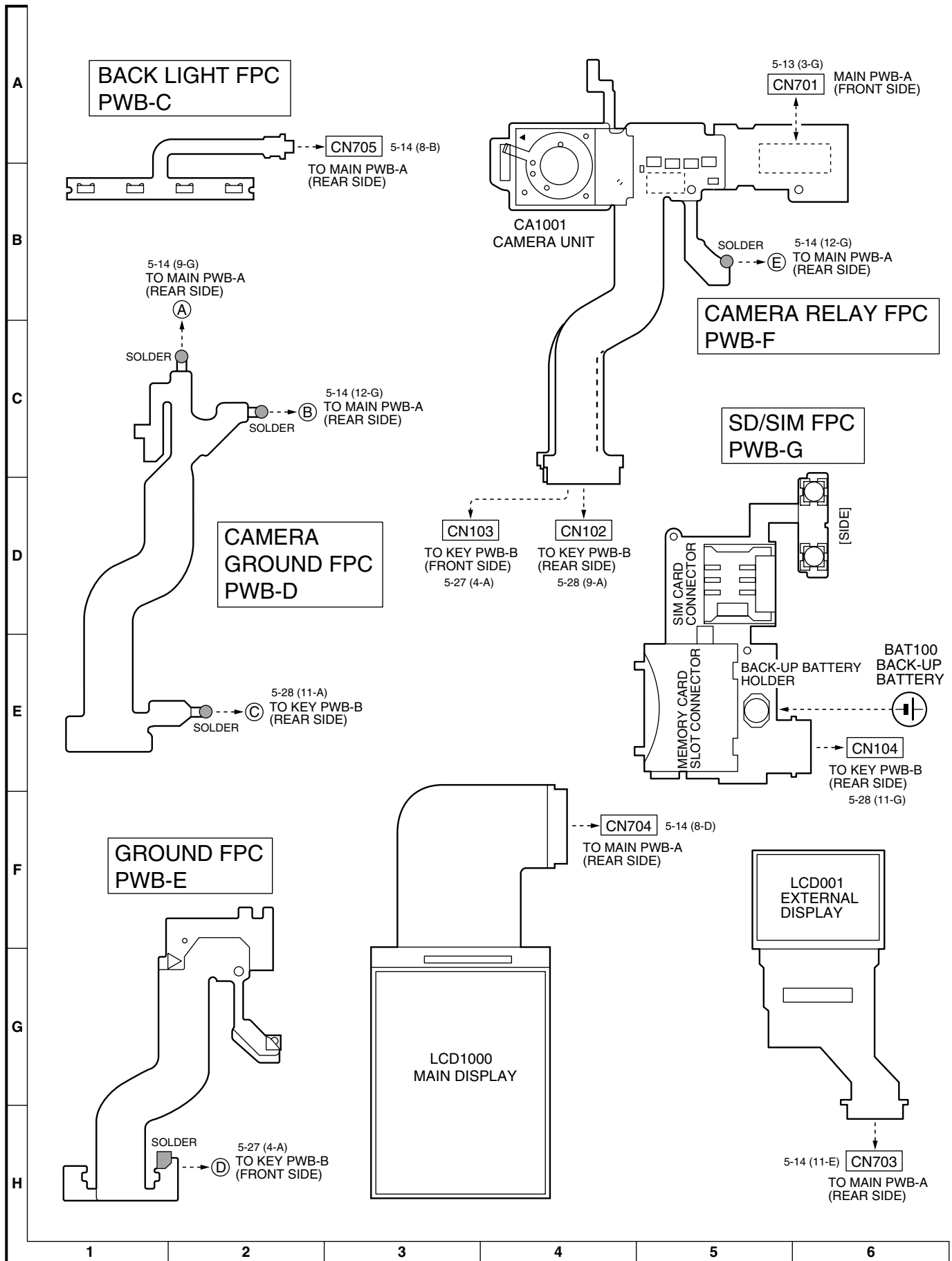

Figure 27 WIRING SIDE P.W.BOARD (5/5)

CHAPTER 6. OTHERS

[1] Function table of IC

IC101 (LRS1B27): 5-LEVEL STACK MEMORY

Pin No.	Terminal name	Input/Output	Description of terminal
1*	NC	–	Not used
2	A20	Input	Address input (NOR Flash, Smartcombo RAM)
3	A11	Input	Address input (NOR Flash, Smartcombo RAM, SRAM)
4	A15	Input	Address input (NOR Flash, Smartcombo RAM, SRAM)
5	A14	Input	Address input (NOR Flash, Smartcombo RAM, SRAM)
6	A13	Input	Address input (NOR Flash, Smartcombo RAM, SRAM)
7	A12	Input	Address input (NOR Flash, Smartcombo RAM, SRAM)
8	GND	–	Ground
9*	NC	–	Not used (VCC IO/NC)
10*	NC	–	Not used
11*	NC	–	Not used
12*	NC	–	Not used
13	SF-RY/BY	Output	Ready busy output (Smartcombo Flash)
14	A16	Input	Address input (NOR Flash, Smartcombo RAM, SRAM)
15	A8	Input	Address input (NOR Flash, Smartcombo RAM, SRAM)
16	A10	Input	Address input (NOR Flash, Smartcombo RAM, SRAM)
17	A9	Input	Address input (NOR Flash, Smartcombo RAM, SRAM)
18	DQ15	Input/Output	Data input/output (NOR Flash, Smartcombo RAM, SRAM) Command, Address, and Data input/output (Smartcombo Flash)
19	S/SC-/WE	Input	Write enable input (SRAM, Smartcombo RAM)
20	DQ14	Input/Output	Data input/output (NOR Flash, Smartcombo RAM, SRAM) Command, Address, and Data input/output (Smartcombo Flash)
21	DQ7	Input/Output	Data input/output (NOR Flash, Smartcombo RAM, SRAM) Command, Address, and Data input/output (Smartcombo Flash)
22*	NC	–	Not used
23*	NC	–	Not used
24	SF-/RE	Input	Read enable input (Smartcombo Flash)
25	F-/WE	Input	Write enable input (NOR Flash)
26*	F-RY/-BY	Output	Ready busy output (NOR Flash) When deleting/writing: VOL When interrupting block delete/write: High-Z (High impedance)
27	A21	Input	Address input (NOR Flash, Smartcombo RAM 2)
28	SC2-CE2	Input	Sleep state input (Smartcombo RAM 2)
29	DQ13	Input/Output	Data input/output (NOR Flash, Smartcombo RAM, SRAM) Command, Address, and Data input/output (Smartcombo Flash)
30	DQ6	Input/Output	Data input/output (NOR Flash, Smartcombo RAM, SRAM) Command, Address, and Data input/output (Smartcombo Flash)
31	DQ4	Input/Output	Data input/output (NOR Flash, Smartcombo RAM, SRAM) Command, Address, and Data input/output (Smartcombo Flash)
32	DQ5	Input/Output	Data input/output (NOR Flash, Smartcombo RAM, SRAM) Command, Address, and Data input/output (Smartcombo Flash)
33*	NC	–	Not used
34	SF/F/SC-VCC	–	Power (NOR Flash ,Smartcombo Flash , Smartcombo RAM)
35	GND	–	Ground
36	/RST	Input	Reset input (NOR Flash) (F-/RST) When deleting block/writing: VIH When reading: VIH Reset: VIL
37	A22	Input	Address input (NOR Flash)
38	SC2-/CE1/NC (F2-/CE)	Input	Chip enable input (Smartcombo RAM 2)
39	DQ12	Input/Output	Data input/output (NOR Flash, Smartcombo RAM, SRAM) Command, Address, and Data input/output (Smartcombo Flash)
40	S/SC1-CE2	Input	Chip enable input (SRAM), sleep state input (Smartcombo RAM 1)
41	S-VCC	–	Power (SRAM)
42	SF/F/SC-VCC	–	Power (NOR Flash ,Smartcombo Flash , Smartcombo RAM)
43*	NC	–	Not used
44	CLE	Input	Command latch enable input (Smartcombo Flash)
45	/WP (F-/WP)	Input	Write protect input (NOR Flash)

Pin No.	Terminal name	Input/Output	Description of terminal
46	VPP (F-VPP)	Input/–	Power voltage detect terminal (NOR Flash) When deleting/writing: VPP = VPPH When deleting/writing is prohibited: VPP < VPPLK
47	A19	Input	Address input (NOR Flash, Smartcombo RAM)
48	DQ11	Input/Output	Data input/output (NOR Flash, Smartcombo RAM, SRAM) Command, Address, and Data input/output (Smartcombo Flash)
49	SF/F/SC-VCC	–	Power (Flash, Smartcombo RAM)
50	DQ10	Input/Output	Data input/output (NOR Flash, Smartcombo RAM, SRAM) Command, Address, and Data input/output (Smartcombo Flash)
51	DQ2	Input/Output	Data input/output (NOR Flash, Smartcombo RAM, SRAM) Command, Address, and Data input/output (Smartcombo Flash)
52	DQ3	Input/Output	Data input/output (NOR Flash, Smartcombo RAM, SRAM) Command, Address, and Data input/output (Smartcombo Flash)
53*	NC	–	Not used
54	ALE	Input	Address latch enable input (Smartcombo Flash)
55	/LB	Input	Byte enable input (DQ0 – DQ7) (Smartcombo RAM, SRAM)
56	/UB	Input	Byte enable input (DQ8 – DQ15) (Smartcombo RAM, SRAM)
57*	NC	–	Not used
58*	NC	–	Not used
59	DQ9	Input/Output	Data input/output (NOR Flash, Smartcombo RAM, SRAM) Command, Address, and Data input/output (Smartcombo Flash)
60	DQ8	Input/Output	Data input/output (NOR Flash, Smartcombo RAM, SRAM) Command, Address, and Data input/output (Smartcombo Flash)
61	DQ0	Input/Output	Data input/output (NOR Flash, Smartcombo RAM, SRAM) Command, Address, and Data input/output (Smartcombo Flash)
62	DQ1	Input/Output	Data input/output (NOR Flash, Smartcombo RAM, SRAM) Command, Address, and Data input/output (Smartcombo Flash)
63*	NC	–	Not used
64*	NC	–	Not used
65	SF-/WE	Input	Write enable input (Smartcombo Flash)
66	A18	Input	Address input (NOR Flash, Smartcombo RAM)
67	A17	Input	Address input (NOR Flash, Smartcombo RAM, SRAM)
68	A7	Input	Address input (NOR Flash, Smartcombo RAM, SRAM)
69	A6	Input	Address input (NOR Flash, Smartcombo RAM, SRAM)
70	A3	Input	Address input (NOR Flash, Smartcombo RAM, SRAM)
71	A2	Input	Address input (NOR Flash, Smartcombo RAM, SRAM)
72	A1	Input	Address input (NOR Flash, Smartcombo RAM, SRAM)
73	SC1-/CE1	Input	Chip enable input (Smartcombo RAM 1)
74*	NC	–	Not used
75*	NC	–	Not used
76*	NC	–	Not used
77	SF-/WP	Input	Write protect input (Smartcombo Flash)
78	SF-/CE	Input	Chip enable input (Smartcombo Flash)
79	A5	Input	Address input (NOR Flash, Smartcombo RAM, SRAM)
80	A4	Input	Address input (NOR Flash, Smartcombo RAM, SRAM)
81	A0	Input	Address input (NOR Flash, Smartcombo RAM, SRAM)
82	F-/CE (F1-/CE)	Input	Chip enable input (NOR Flash)
83	GND	–	Ground
84	/OE	Input	Output enable input (NOR Flash, Smartcombo RAM, SRAM)
85	S-/CE1	Input	Chip enable input (SRAM)
86*	NC	–	Not used
87*	NC	–	Not used

In this unit, the terminal with asterisk mark (*) is (open) terminal which is not connected to the outside.

(TOP VIEW)

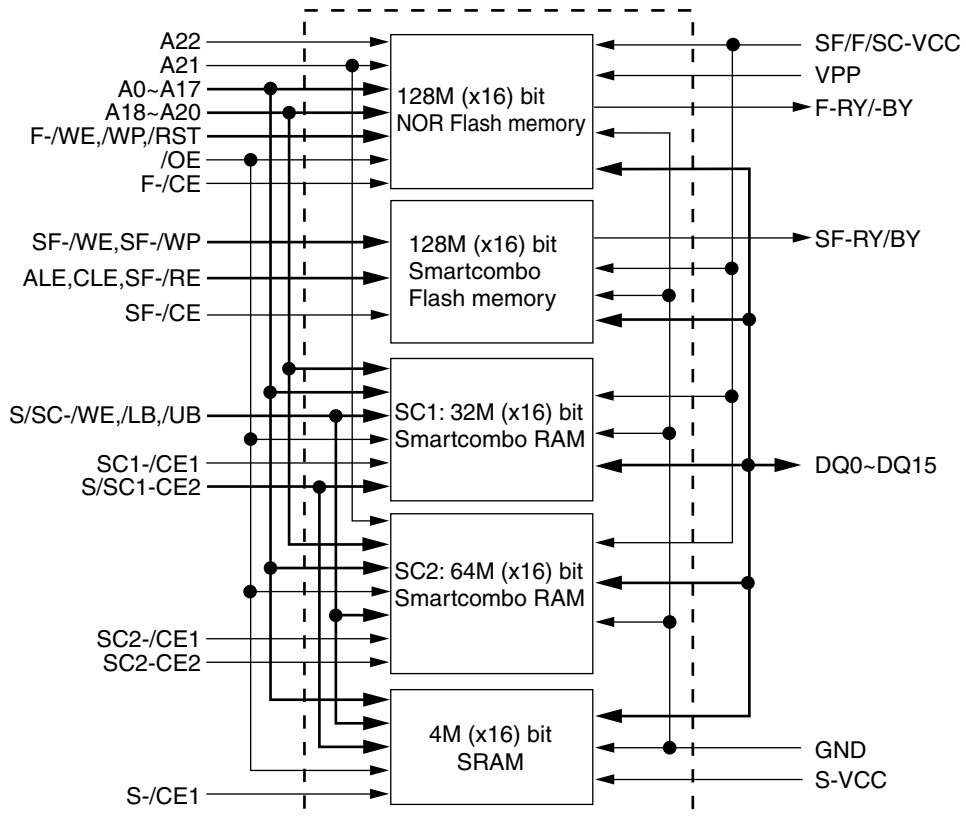
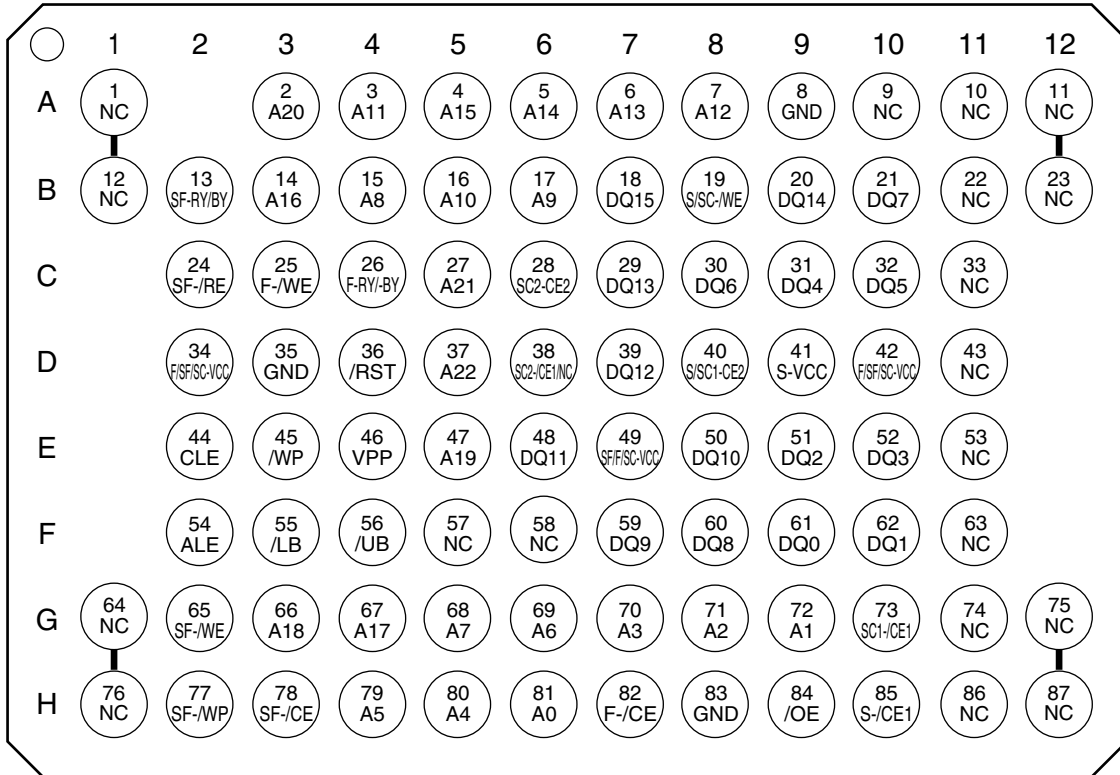

IC103 (AD6535): ANALOG BASEBAND

Pin No.	Terminal name	Input/Output	Description of terminal
1*	TDI	Input	Not used
2	VCXOEN	Input	VCXO supply
3	VBAT3	Input	External interface regulator input
4*	VEXT	Output	Not used
5	VCHG	Input	Charge supply
6	GATEDRIVE	Output	Charge DAC (FET) output control
7	ISENSE	Input	Charge current sense input
8	TEMP2	Input	Temp sensor input for battery
9*	AUXADC2	Input	Not used
10	REFBB	Output	Baseband transmit & receive voltage reference
11	AGND2	–	Analog baseband ground
12	IP	Input/Output	I-channel positive input/output
13	IN	Input/Output	I-channel negative input/output
14	QN	Input/Output	Q-channel positive input/output
15	QP	Input/Output	Q-channel negative input/output
16*	RSVD_A16	–	Not used
17*	TMS	Input	Not used
18*	TCK	Input	Not used
19	VBAT3	Input	External interface regulator input
20*	VEXT	Output	Not used
21	CHGOSC	Input	Charge oscillator capacitor
22	BATTYPE	Input	Battery type identification input
23	CHGDACREF	Output	Charge DAC reference
24	VBATSENSE	Input	Battery voltage sense input
25	TEMP1	Input	Temp sensor input for camera
26	AUXADC1	Input	Auxiliary ADC input for temp. sensor adjustment
27	REFOUT	Output	Voltage reference output
28	PA	Output	Power amplifier control output
29	AGND0	–	Analog ground
30	AFCDAC	Output	Automatic frequency control DAC output
31	REF	Output	Voltage reference
32	AGND1	–	Analog ground
33*	TDO	Output	Not used
34*	GPI	Input	Not used
35	VBAT1	Input	Voltage controlled crystal oscillator regulator input
36*	RSVD_C16	–	Not used
37	INT	Output	Digital BB interrupt
38	ASDO	Output	Audio serial port data output
39	REFCHG	Output	Voltage reference output
40	VVCXO	Output	Voltage controlled crystal oscillator supply 2.71 - 2.79 V (VT)
41	ASDI	Input	Audio serial port data input
42	BSDO	Output	Baseband serial port data output
43	VUSB	Output	USB interface supply 3.0 - 3.6 V
44	VAPPGATE	Output	Application regulator pass device gate control
45	BSIFS	Input	Baseband serial port input framing signal
46	ASFS	Output	Audio serial port framing signal
47	VUSBIN	Input	USB interface regulator input
48	VAPP	Output	Application supply 2.75 - 3.3 V
49	BSOFS	Output	Baseband serial port output framing signal
50	BSDI	Input	Baseband serial port data input
51	VBAT2	Input	Analog baseband regulator input
52*	NC_G16	–	Not used
53	CSDO	Output	Control serial port data output
54	CSDI	Input	Control serial port data input
55	VBAT2	Input	Analog baseband regulator input
56	VABB	Output	Analog baseband supply
57	ASM	Input	Advanced state machine
58	MCLKEN	Output	Master clock enable
59	AOUT1P	Output	Receiver audio positive output
60	AOUT3L	Output	Headset receiver audio L-channel output
61	RXON	Input	Baseband receive section control
62	TXON	Input	Baseband transmit section control
63	AOUT1N	Output	Receiver audio negative output

Pin No.	Terminal name	Input/Output	Description of terminal
64	AOUT3R	Output	Headset receiver audio R-channel output
65	MCLK	Input	Master clock
66	CSFS	Input	Control serial port framing signal
67	AGND3	–	Analog audio ground
68	LIGHT1	Output	Charge LED control
69	ABBRESET	Input	Reset input
70	DGND	–	Digital ground
71	LIGHT2	Output	USB charge enable
72	LIGHT3	Output	Key-pad LED control
73	VCORE	Output	Digital core supply 1.72 - 1.9 V
74	VCOREIN	Input	Digital core regulator input
75	LGND	–	Light driver ground
76	VMIC	Output	Microphone supply 2.4 - 2.6 V
77	VCORE	Output	Digital core supply 1.72 - 1.9 V
78	VMEMIN	Input	Memory interface regulator input
79	AIN2P	Input	Headset mic audio positive input
80	AIN1P	Input	Mic audio positive input
81	CRST	Output	Power-on reset capacitor
82	VMEMIN	Input	Memory interface regulator input
83	VMEMSEL	Input	Memory supply voltage selection
84	VBAT5	Input	Back-up battery regulator input
85	VBAT4	Input	SIM interface regulator input
86	VRTCIN	Input	Real-time clock regulator input
87	DBBON	Input	Digital BB supply regulator on signal
88	SGND	–	AOUT2P/N ground
89*	AOUT2N	Output	Not used
90*	SPWR	Input	Not used
91*	AOUT2P	Output	Not used
92*	NC_R12	–	Not used
93	AIN3L	Input	Sound IC audio L-channel input
94	AIN3R	Input	Sound IC audio R-channel input
95	AIN2N	Input	Headset mic audio negative input
96	AIN1N	Input	Mic audio negative input
97	RESET	Output	Reset output
98	VMEM	Output	Memory interface supply 2.75 - 3.05 V
99	VMEM	Output	Memory interface supply 2.75 - 3.05 V
100	VBACK	Output	Back-up battery supply 2.72 - 3.05 V
101	VBACKSEL	Input	Back-up battery supply voltage selection
102	VSIM	Output	SIM interface supply 2.75 - 2.95 V
103	VRTC	Output	Real-time clock supply 1.6 - 2.0 V
104	SGND	–	AOUT2P/N ground
105*	AOUT2N	Output	Not used
106*	SPWR	Input	Not used
107*	AOUT2P	Output	Not used
108	LDOEN	Output	Regulator enable output
109	KEYOUT	Output	Power-on key output
110	KEYON	Input	Power-on key input
111	IBIAS	Output	Regulator bias current reference
112	AGND4	–	Power management analog ground
113	AGND0	–	Thermal ground for power supply
114	AGND0	–	Thermal ground for power supply
115	AGND0	–	Thermal ground for power supply
116	AGND0	–	Thermal ground for power supply
117	AGND0	–	Thermal ground for power supply
118	AGND0	–	Thermal ground for power supply
119	AGND0	–	Thermal ground for power supply
120	AGND0	–	Thermal ground for power supply
121	AGND0	–	Thermal ground for power supply
122	AGND0	–	Thermal ground for power supply
123	AGND0	–	Thermal ground for power supply
124	AGND0	–	Thermal ground for power supply
125	AGND0	–	Thermal ground for power supply
126	AGND0	–	Thermal ground for power supply
127	AGND0	–	Thermal ground for power supply

Pin No.	Terminal name	Input/Output	Description of terminal
128	AGND0	–	Thermal ground for power supply
129	AGND0	–	Thermal ground for power supply
130	AGND0	–	Thermal ground for power supply
131	AGND0	–	Thermal ground for power supply
132	AGND0	–	Thermal ground for power supply
133	AGND0	–	Thermal ground for power supply
134	AGND0	–	Thermal ground for power supply
135	AGND0	–	Thermal ground for power supply
136	AGND0	–	Thermal ground for power supply
137	AGND0	–	Thermal ground for power supply
138	AGND0	–	Thermal ground for power supply
139	AGND0	–	Thermal ground for power supply
140	AGND0	–	Thermal ground for power supply
141	AGND0	–	Thermal ground for power supply
142	AGND0	–	Thermal ground for power supply
143	AGND0	–	Thermal ground for power supply
144	AGND0	–	Thermal ground for power supply
145	AGND0	–	Thermal ground for power supply
146	AGND0	–	Thermal ground for power supply
147	AGND0	–	Thermal ground for power supply
148	AGND0	–	Thermal ground for power supply

In this unit, the terminal with asterisk mark (*) is (open) terminal which is not connected to the outside.

IC105 VHIYMU762C+-1L (YMU762C): SOUND

Pin No.	Terminal name	Input/Output	Description of terminal
1	CLKI	Input	Clock input terminal
2	LED	Output	External LED control terminal
3	/IRQ	Output	Interrupt output terminal
4	/RST	Input	Hardware reset input terminal
5*	NC	-	Not used
6	PLL	-	Built-in PLL capacitor terminal
7	VDD	-	Power supply (Typ + 3.0 V)
8	VSS	-	Ground
9	VREF	-	Analog reference voltage terminal
10	HPOUT-L/MONO	Output	Headphone output L-ch
11	HPOUT-R	Output	Headphone output R-ch
12	EQ1	-	Equalizer terminal 1
13	EQ2	-	Equalizer terminal 2
14	EQ3	-	Equalizer terminal 3
15	SPVDD	-	Analog power supply for speaker amplifier (Typ + 3.6 V)
16	SPVSS	-	Analog ground for speaker amplifier
17	SPOUT1	Output	Speaker terminal 1
18	SPOUT2	Output	Speaker terminal 2
19	MTR	Output	External motor control terminal
20	D7	Input/Output	CPU I/F data bus 7
21	D6	Input/Output	CPU I/F data bus 6
22	D5	Input/Output	CPU I/F data bus 5
23	D4	Input/Output	CPU I/F data bus 4
24	D3	Input/Output	CPU I/F data bus 3
25	D2	Input/Output	CPU I/F data bus 2
26	D1	Input/Output	CPU I/F data bus 1
27	D0	Input/Output	CPU I/F data bus 0
28	/WR	Input	CPU I/F write enable
29	/CS	Input	CPU I/F chip select input
30	A0	Input	CPU I/F address signal
31	/RD	Input	CPU I/F read enable
32	IOVDD	-	Power supply for terminal

In this unit, the terminal with asterisk mark (*) is (open) terminal which is not connected to the outside.

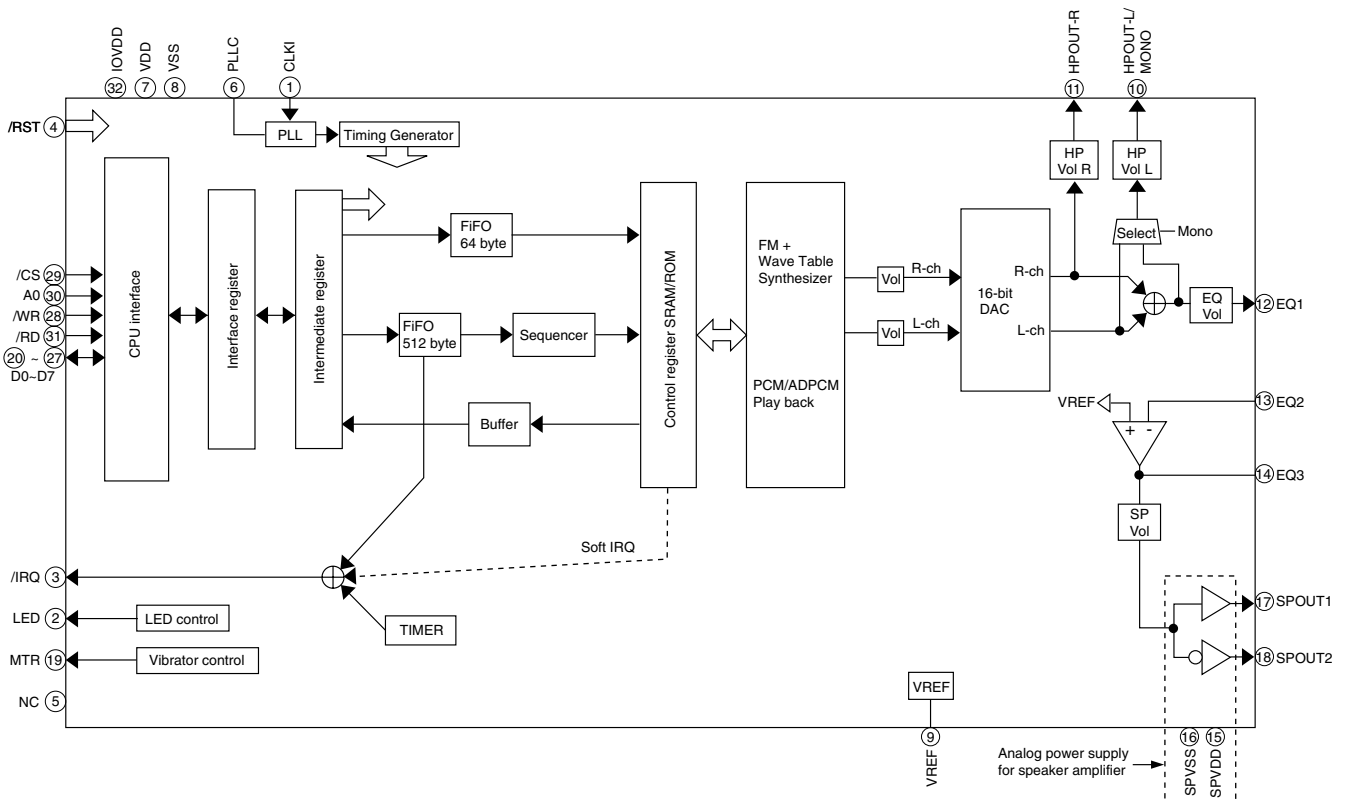

IC106 (AD6529B): DIGITAL BASEBAND

Pin No.	Terminal name	Input/Output	Description of terminal
1	ASDO	Output	Audio serial port data output to analog BB
2	BSDI	Input	Baseband serial port data input from analog BB
3	BSOFS	Output	Baseband serial port output framing signal output to analog BB
4	GPIO_48	Input	Hook switch of hands free kit (earphone) detection
5	VINT	Input	Analog BB interface power supply 1.7 - 3.3 V (VCORE)
6	GPO_29	Output	Analog BB reset output (ABBRESET)
7	GPO_5	Output	Advanced state machine of analog BB
8	VDDRTC	Input	RTC power supply 1.0 - 1.9 V (VRTC)
9	VSSRTC	–	RTC ground
10	MC_DAT[0]	Input/Output	SD interface data bus 0
11	GPIO_22	Output	RSP for main LCD controller
12	GPIO_56	Input	Boot control 2 (Hardware version select)
13	KEYPADCOL[4]	Output	KEYIN signal output 4
14	KEYPADCOL[1]	Output	KEYIN signal output 1
15	KEYPADROW[4]	Input	KEYIN signal input 4
16	KEYPADROW[2]	Input	KEYIN signal input 2
17	GPIO_38	Input	Interrupt input from sound generator IC
18	GPIO_36	Output	Mode select 2 for interface IC / AOUT3 bias control
19	ASDI	Input	Audio serial port data input from analog BB
20	GPIO_35	Input	SD card interface write protect
21	ADD[0]	Output	Write protect control for flash memory 2
22	ASFS	Input	Audio serial port framing signal input from analog BB
23	BSIFS	Input	Baseband serial port input framing signal input from analog BB
24	BSDO	Output	Baseband serial port data output to analog BB
25	CSDI	Input	Control serial port data input from analog BB
26*	GPO_6	Output	Not used
27	GPO_0	Output	Analog baseband receive section control (RXON)
28	OSCOUT	Output	32.768 kHz crystal oscillator output
29	MC_DAT[2]	Input/Output	SD interface data bus 2
30	VMC	Input	SD card interface power supply 1.7 - 3.3 V (VAPP)
31	VCC	Input	Core power supply 1.7 - 1.9 V (VCORE)
32	KEYPADCOL[3]	Output	KEYIN signal output 3
33	KEYPADCOL[2]	Output	KEYIN signal output 2
34	GPIO_39	Output	USB PU control for interface IC
35	GPIO_37	Input	Interrupt input from analog BB
36	GPIO_34	Output	UART_TXD for Bluetooth module
37	ADD[4]	Output	Processor address bus 4
38	ADD[2]	Output	Processor address bus 2
39	GND	–	Ground
40	KEYPADROW[0]	Input	KEYIN signal input 0
41	VEXT	Input	System interface power supply 2.4 - 3.3 V (VINT)
42	GPO_23	Output	SLEEP control for SRAM 2
43	ADD[7]	Output	Processor address bus 7
44	VMEM	Input	Memory power supply 2.7 - 3.3 V (VMEM)
45	ADD[1]	Output	Processor address bus 1
46	CSDO	Output	Control serial port data output to analog BB
47	CLKOUT_GATE	Input	Master clock enable from analog BB (MCLKEN)
48	GPO_1	Output	Analog baseband transmit section control (TXON)
49	OSCIN	Input	32.768 kHz crystal oscillator input
50	MC_CMD	Input/Output	SD interface CMD (SD_CMD)
51	GPIO_55	Input	Boot control 1 (Hardware version select)
52	GND	–	Ground
53	KEYPADROW[3]	Input	KEYIN signal input 3
54	KEYPADROW[1]	Input	KEYIN signal input 1
55	GPIO_33	Input	UART_RXD for Bluetooth module
56	GPIO_17	Output	PCM data output for Bluetooth module
57	ADD[11]	Output	Processor address bus 11
58	ADD[9]	Output	Processor address bus 9
59	ADD[5]	Output	Processor address bus 5
60	ADD[3]	Output	Processor address bus 3
61	GND	–	Ground
62	VCC	Input	Core power supply 1.7 - 1.9 V (VCORE)
63	PWRON	Output	System power control for analog BB

Pin No.	Terminal name	Input/Output	Description of terminal
64	MC_DAT[1]	Input/Output	SD interface data bus 1
65	GND	–	Ground
66	VEXT	Input	System interface power supply 2.4 - 3.3 V (VINT)
67	KEYPADCOL[0]	Output	KEYIN signal output 0
68	VEXT	Input	System interface power supply 2.4 - 3.3 V (VINT)
69	GPIO_15	Input	PCM data input for Bluetooth module
70	GPIO_16	Output	PCM SYNC output for Bluetooth module
71	ADD[13]	Output	Processor address bus 13
72	ADD[12]	Output	Processor address bus 12
73	ADD[8]	Output	Processor address bus 8
74	ADD[6]	Output	Processor address bus 6
75	GPO_22	Output	VPP control for flash memory 1
76	GPIO_14	Output	PCM clock output for Bluetooth module
77	GPIO_10	Input	USB detection
78	GPIO_12	Output	Reset output for main LCD controller/Sub LCD driver/Power management IC
79	VMEM	Input	Memory power supply 2.7 - 3.3 V (VMEM)
80	ADD[14]	Output	Processor address bus 14
81	GND	–	Ground
82	VCC	Input	Core power supply 1.7 - 1.9 V (VCORE)
83	ADD[10]	Output	Processor address bus 10
84	CLKOUT	Output	13 MHz clock output for analog BB (CLKOUT)
85	MC_DAT[3]	Input/Output	SD interface data bus 3
86	GND	–	Ground
87	GND	–	Ground
88	GPIO_13	Input	Interrupt input from camera module
89	GPIO_7	Input	Hands free kit (earphone) detection
90	GPIO_9	Input	Manufacturer specific input from I/O connector
91	ADD[19]	Output	Processor address bus 19
92	ADD[17]	Output	Processor address bus 17
93	ADD[18]	Output	Processor address bus 18
94	ADD[15]	Output	Processor address bus 15
95	ADD[16]	Output	Processor address bus 16
96	CSFS	Output	Control serial port framing signal output to analog BB
97	MC_CLK	Input	SD interface clock (SD_CLK)
98	VCC	Input	Core power supply 1.7 - 1.9 V (VCORE)
99	GPIO_11	Input	Flip switch detection
100	GPIO_8	Input	Stereo/monaural detection for hands free kit (earphone)
101	GPIO_5	Input	SD card detection
102	GPIO_6	Input	Interrupt input from main LCD controller
103	ADD[22]	Output	Processor address bus 22
104	ADD[21]	Output	Processor address bus 21
105	GPIO_40	Output	13 MHz clock output for main LCD controller & Sound generator IC
106	ADD[20]	Output	Processor address bus 20
107	GND	–	Ground
108	ADD[23]	Output	Processor address bus 23
109	GND	–	Ground
110	VEXT	Input	System interface power supply 2.4 - 3.3 V (VINT)
111	GND	–	Ground
112	GPIO_4	Output	UART_CTS for Bluetooth module
113	GPIO_2	Output	USB charge current control
114	GPIO_3	Input	UART_RTS for Bluetooth module
115	DATA[2]	Input/Output	Processor data bus 2
116	DATA[0]	Input/Output	Processor data bus 0
117	DATA[5]	Input/Output	Processor data bus 5
118	DATA[1]	Input/Output	Processor data bus 1
119	DATA[3]	Input/Output	Processor data bus 3
120	VCC	Input	Core power supply 1.7 - 1.9 V (VCORE)
121	DMINUS	Input	USB D-
122	GPIO_18	Output	JTAG TCK
123	GND	–	Ground
124	GPIO_1	Input	IrDA receive data
125	USC[5]	Input	USC pin (CTS/Ginie_TX)
126	GPIO_0	Output	IrDA transmit data
127	DATA[4]	Input/Output	Processor data bus 4

Pin No.	Terminal name	Input/Output	Description of terminal
128	VMEM	Input	Memory power supply 2.7 - 3.3 V (VMEM)
129	GND	–	Ground
130	VCC	Input	Core power supply 1.7 - 1.9 V (VCORE)
131	USC[6]	Input	USC pin (GPIO_31/Ginie_RX)
132	VCC	Input	Core power supply 1.7 - 1.9 V (VCORE)
133	USC[2]	Input	USC pin (TXD)
134	USC[4]	Input	USC pin (RTS/Ginie_RX)
135	DATA[7]	Input/Output	Processor data bus 7
136	DATA[6]	Input/Output	Processor data bus 6
137	GND	–	Ground
138	DATA[9]	Input/Output	Processor data bus 9
139	DATA[13]	Input/Output	Processor data bus 13
140	NR0MCS1	Output	Chip select for flash memory 1
141	GPIO_42	Output	Chip select for main LCD controller
142	CLKIN	Input	13 MHz clock input
143	VSIM	Input	SIM power supply 1.7 - 3.3 V (VSIM)
144	GND	–	Ground
145	USC[3]	Input	Pull up to VINT
146	USC[1]	Input	USC pin (RXD)
147	GND	–	Ground
148	USC[0]	Input	USC pin (Ginie_TX)
149	DATA[10]	Input/Output	Processor data bus 10
150	DATA[8]	Input/Output	Processor data bus 8
151	NRD	Output	Processor read strobe
152	DATA[14]	Input/Output	Processor data bus 14
153	GND	–	Ground
154	NRAMCS2	Output	Chip select for SRAM 2
155	GPIO_44	Input	Wakeup mode select
156	VSSUSB	–	USB ground
157	GPIO_47	Output	Camera module reset
158	GPIO_20	Output	JTAG TDI
159	CLKON	Output	13 MHz oscillator power control signal (VCXOEN)
160	VCC	Input	Core power supply 1.7-1.9V (VCORE)
161	GPO_18	Output	SYNTH enable for RF (SYNTHEN)
162	GPO_21	Output	SYNTH clock output for RF (SYNTHCLK)
163	DATA[12]	Input/Output	Processor data bus 12
164	DATA[11]	Input/Output	Processor data bus 11
165	NWE	Output	Processor write strobe
166	VEXT	Input	System interface power supply 2.4 - 3.3 V (VINT)
167	GPO_11	Output	Band select 4 for RF (BS4)
168	GPO_20	Output	SYNTH data output for RF (SYNTHDATA)
169	DATA[15]	Input/Output	Processor data bus 15
170	VMEM	Input	Memory power supply 2.7 - 3.3 V (VMEM)
171	NADV	Output	Address latch enable for flash memory 2
172	NGPCS1	Output	Chip select for flash memory 2
173	VMEM	Input	Memory power supply 2.7 - 3.3 V (VMEM)
174	GPIO_45	Output	Chip select for 4M SRAM
175	GPIO_46	Output	Chip select for sound generator IC
176	DPLUS	Input	USB D+
177	SIMCLK	Output	System interface clock output
178	JTAGEN	Input	JTAG enable
179	VEXT	Input	SIM power supply 2.4 - 3.3 V (VINT)
180	GPO_3	Output	Incoming LED OFF control
181	GPO_4	Output	Mode select 1 for interface IC
182	GPO_7	Output	Bluetooth module power ON/OFF control
183	GPO_16	Output	Band select 1 for RF (BS1)
184	GPO_17	Output	Band select 2 for RF (BS2)
185	NHWR/NUSB	Output	Processor high write strobe
186	GPO_19	Output	Mode select 3 for interface IC
187	NLWR/NLSB	Output	Processor low write strobe
188	NWAIT	Input	Processor wait input
189	NRESET	Input	System reset input
190*	BURSTCLK	Output	Not used
191	NRAMCS1	Output	Chip select for SRAM 1

Pin No.	Terminal name	Input/Output	Description of terminal
192	NAUXCS1	Output	Command latch enable for flash memory 2
193	GPIO_43	Output	Chip select for Camera module
194	VDDUSB	Input	USB power supply 2.8 - 3.3 V (VUSB)
195	GPIO_23	Output	SIM interface reset
196	SIMDATAIO	Input/Output	SIM interface data input/output
197	GPIO_24	Output	Sound generator IC reset
198	GPIO_19	Output	JTAG TMS
199	GPIO_21	Output	JTAG TDO
200	GPO_2	Output	Write protect control for flash memory 1
201	GND	-	Ground
202	GPO_8	Output	IrDA power ON/OFF control
203	GPO_9	Output	Band select 3 for RF (BS3)
204	GPO_10	Output	BUF OFF for main LCD controller

In this unit, the terminal with asterisk mark (*) is (open) terminal which is not connected to the outside.

IC107 VHIEW6671++-1R (EW6671): HALL

Pin No.	Terminal name	Input/Output	Description of terminal
1	VDD	Input	Input
2	GND	-	Ground
3	OUT	Output	Output

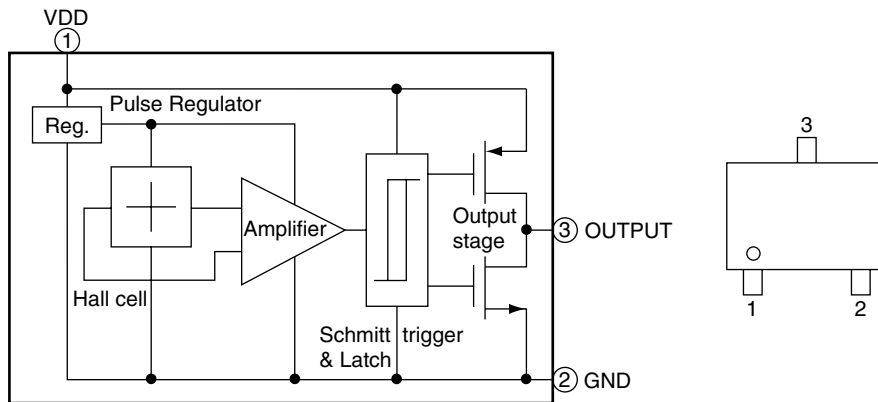

IC108 VHIR3112Q26-1L (R3112Q261A): VOLTAGE DETECTOR

Pin No.	Terminal name	Input/Output	Description of terminal
1	VDD	-	Power supply
2	GND	-	Ground
3	CD	Input	External condenser connection terminal for delay
4	OUT	Output	Output terminal (L: when output is detected, H: when output is canceled)

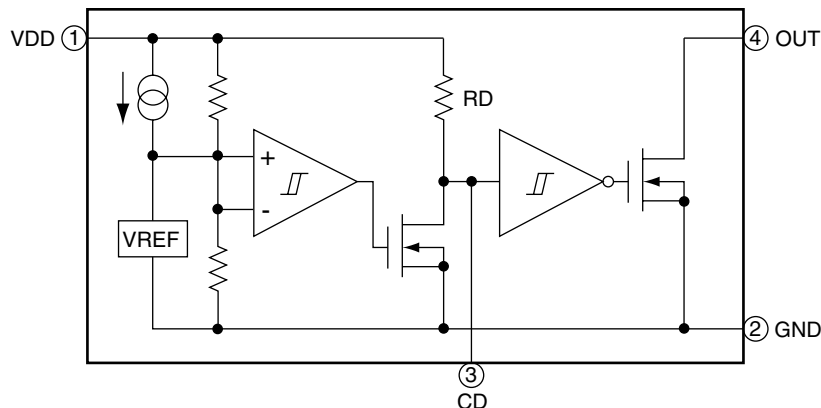

IC109 VHINJ287130-1L (NJM2871F03): 3.0 V REGULATOR

Pin No.	Terminal name	Input/Output	Description of terminal
1	CONT	Input	Control
2	GND	-	Ground
3	NB	-	Noise bypass
4	VOUT	Output	Output
5	VIN	Input	Input

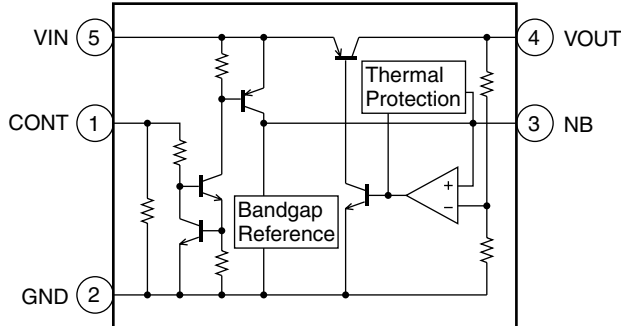

IC111 VHIR116030B-1L (R1160N301B): REGULATOR
IC703 VHIR116018B-1L (R116018B): 1.8 V REGULATOR

Pin No.	Terminal name	Input/Output	Description of terminal
1	VDD	Input	Input
2	GND	-	Ground
3	CE	Input	Chip enable
4	ECO	Input	High speed/low consumption selector switch
5	VOUT	Output	Output

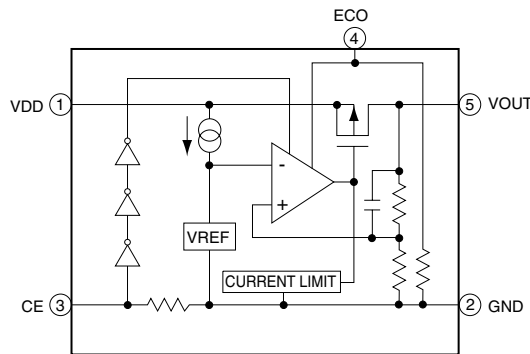

IC113, 706 VHITC7SZ08A-1L (TC7SZ08A): AND GATE/LOGIC

Pin No.	Terminal name	Input/Output	Description of terminal
1	A	Input	Signal input
2	B	Input	Signal input
3	GND	-	Ground
4	Y	Output	Logic value output
5	VCC	Input	Power supply

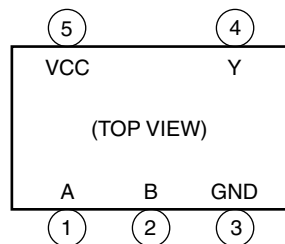

IC114 RH-IXA007AFZZL (HA1631S03CME): COMPARATOR

Pin No.	Terminal name	Input/Output	Description of terminal
1	IN+	Input	Input
2	VSS	-	Ground
3	IN-	Input	Input
4	VOUT	Output	Output
5	VDD	-	Power supply

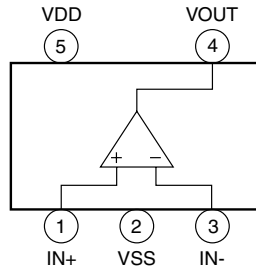

IC115 VHIXC61CN27-1L (XC61CN27): REGULATOR

Pin No.	Terminal name	Input/Output	Description of terminal
1	VOUT	Output	Output
2	VIN	Input	Supply voltage input
3*	NC	-	Not used
4	GND	-	Ground

In this unit, the terminal with asterisk mark (*) is (open) terminal which is not connected to the outside.

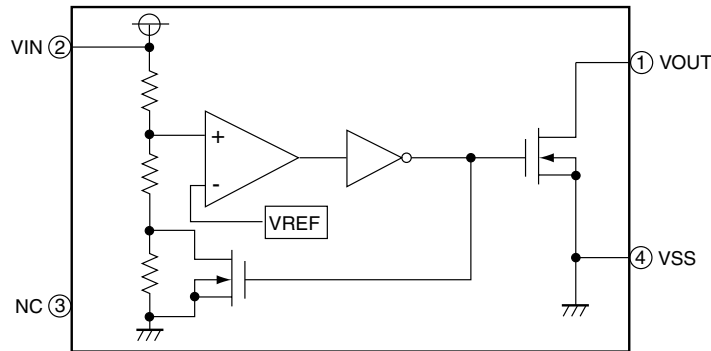

IC116 VHIRQ5RW45B-1L (RQ5RW45B): 4.5 V REGULATOR

Pin No.	Terminal name	Input/Output	Description of terminal
1	GND	-	Ground
2	VDD	-	Power supply
3	VOUT	Output	Output
4	CE	Input	Chip enable

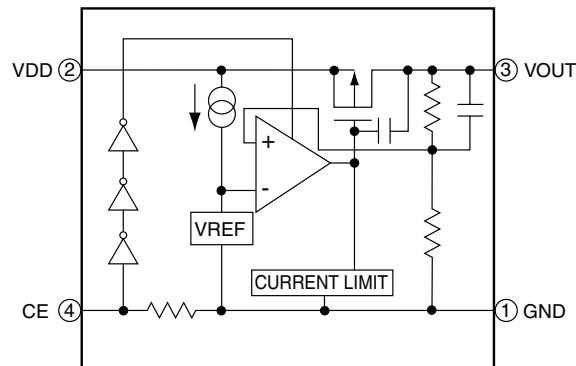

IC502 VHIBU7870KN-1L (BU7870KN): USB CONTROLLER

Pin No.	Terminal name	Input/Output	Description of terminal
1	MODESEL1	Input	Operation mode switching 1
2	MODESEL2	Input	Operation mode switching 2
3	UART_RXD	Output	UART_RXD output
4	UART_TXD	Input	UART_TXD input
5	CPUVDD	-	Digital power supply
6	UART_RTS	Input	UART_RTS input
7	BSYNC	Input	BSYNC input
8	UART_CTS	Output	UART_CTS output
9	BDATA	Input	BDATA input
10	BCNT	Input	BDATA input control
11	MODESEL3	Input	Operation mode switching 3
12	TXANAOUT	Output	Hands free sending external output
13	RXANAIN	Input	Hands free receiving external input
14	GND1	-	Ground
15	RXANAOUT	Output	Hands free receiving output
16	TXANAIN	Input	Hands free sending input
17*	NC	-	Not used
18	BDATA/CTS	Input/Output	BDATA/CTS switching external input/output
19	BSYNC/RTS	Output	BSYNC/RTS switching external output
20	USBD-/TXD	Input/Output	USBD-/TXD switching external input/output
21	GND2	-	Ground
22	USBD+/RXD	Input/Output	USBD+/RXD switching external input/output
23	CPU_USB_D+	Input/Output	CPU_USB_D+ input/output
24	CPU_USB_D-	Input/Output	CPU_USB_D- input/output
25	REG33	-	Power supply voltage for USB
26	PU15	Output	PMOS open drain output
27	PUEA	Input	PU15 control input
28	GND3	-	Ground

In this unit, the terminal with asterisk mark (*) is (open) terminal which is not connected to the outside.

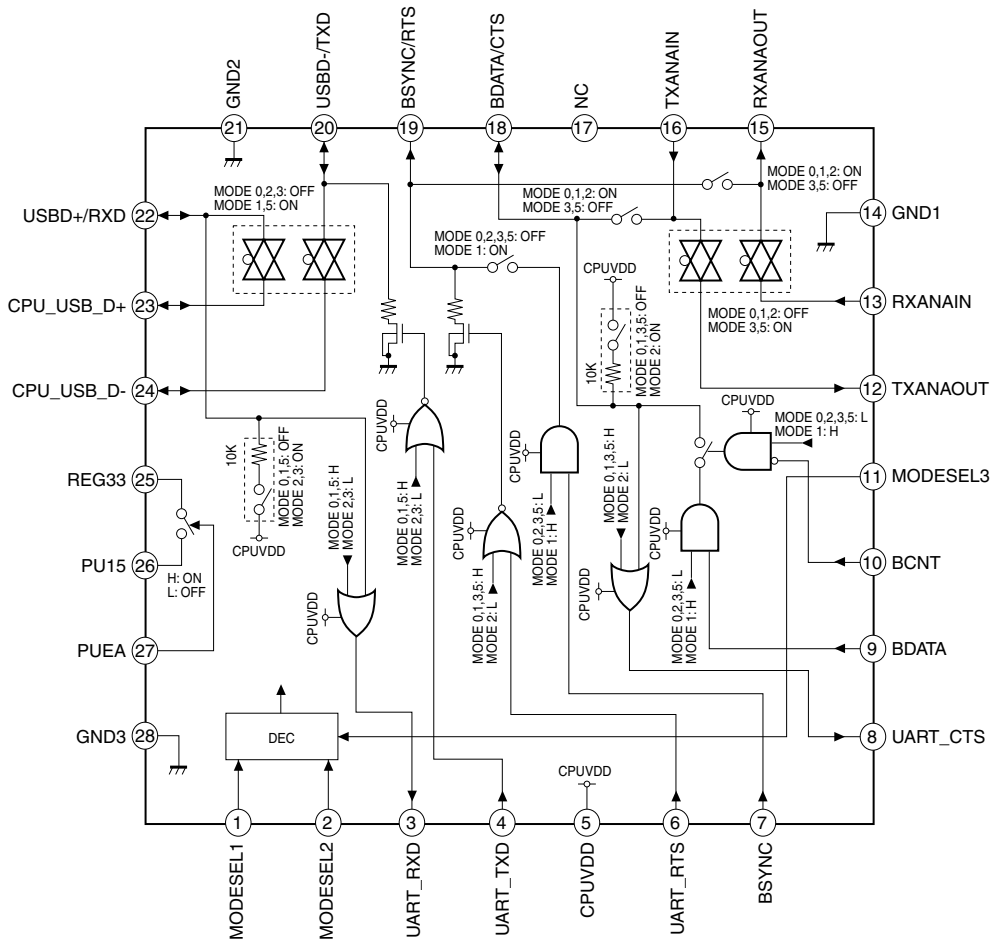

IC505 VHXC620930-1L (XC620930): REGULATOR

Pin No.	Terminal name	Input/Output	Description of terminal
1	VIN	Input	Input
2	VSS	–	Ground
3	CE	Input	ON/OFF Control
4*	NC	–	Not used
5	VOUT	Output	Output

In this unit, the terminal with asterisk mark (*) is (open) terminal which is not connected to the outside.

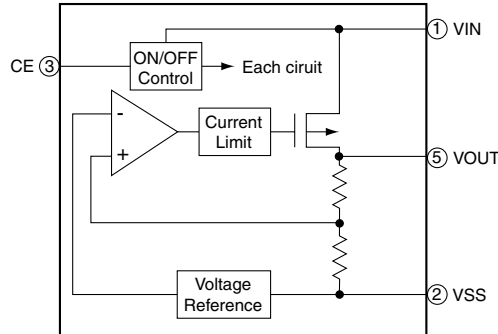

IC506 RUNTZA005AFZZL (UGNZ2): BLUETOOTH MODULE

Pin No.	Terminal name	Input/Output	Description of terminal
1*	USBP	Input/Output	USB DATA+ (Not used)
2*	USBN	Input/Output	USB DATA- (Not used)
3	UART_RTS	Output	UART/Ready to send to DTE
4	GND	–	Ground
5	GND	–	Ground
6	UART_TxD	Output	UART/TxD to DTE
7	UART_RxD	Input	UART/RxD from DTE
8	UART_CTS	Input	UART/Clear to send from DTE
9	PIO8	Input/Output	General purpose I/O
10	VCC_IO	Input	Positive supply voltage for IO voltage Connect the VCC, if IO voltage is same as VCC
11	VCC	Input	Main supply voltage input 1 Regulated DC source recommended
12	PCM_OUT	Output	PCM data stream output
13	PCM_SYNC	Input/Output	Connection to PCM frame sync Input/output of 8 kHz
14*	XTAL_IN	Input	Ext clock in (Not used)
15*	XTAL_OUT	Input	Ext clock out (Not used)
16	RESETB	Input	System reset
17	VDD18V	Output	VDD_CORE decoupling capacitor
18	PCMCLK	Input/Output	Connction to PCM reference Clock input/output of 256 kHz
19	PCM_IN	Input	PCM data stream input
20	PIO5	Input/Output	General purpose I/O
21	PIO6	Input/Output	General purpose I/O
22	PIO3	Input/Output	General purpose I/O
23	GND	–	Ground
24	SPIMOSI	Input/Output	For factory use only
25	SPICLK	Input/Output	For factory use only
26	PIO4	Input/Output	General purpose I/O
27	PIO7	Input/Output	General purpose I/O
28	PIO1	Input/Output	General purpose I/O
29	RF_IO	Input/Output	RF input/output
30	GND	–	Ground
31	SPIMISO	Input/Output	For factory use only
32*	SPICSB	Input/Output	For factory use only (Not used)
33	PIO2	Input/Output	General purpose I/O
34	PIO0	Input/Output	General purpose I/O

In this unit, the terminal with asterisk mark (*) is (open) terminal which is not connected to the outside.

IC507 VHITC7SET00FU- (TC7SET00FU): LOGIC

Pin No.	Terminal name	Input/Output	Description of terminal
1	INB	Input	Input B
2	INA	Input	Input A
3	GND	-	Ground
4	OUT Y	Output	Output Y
5	VCC	-	Power supply

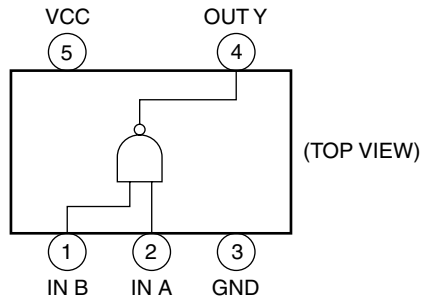

IC508 VHI817A30NB-1R (817A30NB): 3.0 V REGULATOR

Pin No.	Terminal name	Input/Output	Description of terminal
1	VSS	-	Ground (GND)
2	VIN	Input	Input voltage (VDD)
3	VOUT	Output	Output voltage
4	NC	-	Not used (CE)

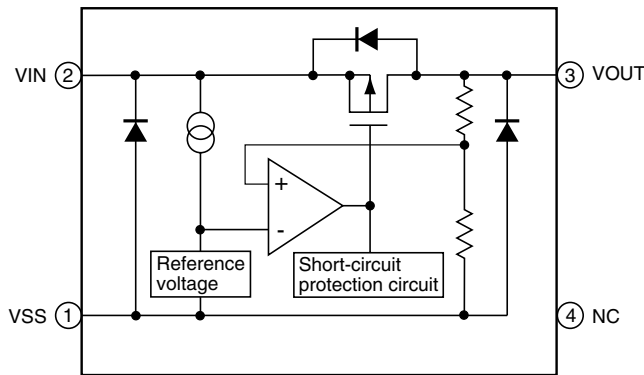

IC509 VHILVC2G34P-1R (LVC2G34P): BUFFER

Pin No.	Terminal name	Input/Output	Description of terminal
1	1A	Input	Input
2	GND	-	Ground
3	2A	Input	Input
4	2Y	Output	Output
5	VCC	-	Power supply
6	1Y	Output	Output

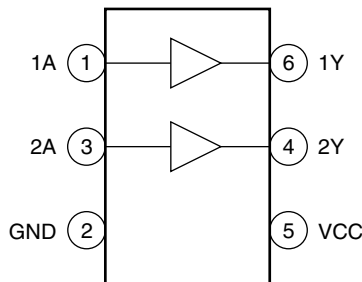

IC701 VHIR116025B-1L (R116025B): 2.5V REGULATOR

Pin No.	Terminal name	Input/Output	Description of terminal
1	VDD	Input	Input
2	GND	-	Ground
3	CE	Input	Chip enable
4	ECO	Input	High speed/low consumption selector switch
5	VOUT	Output	Output

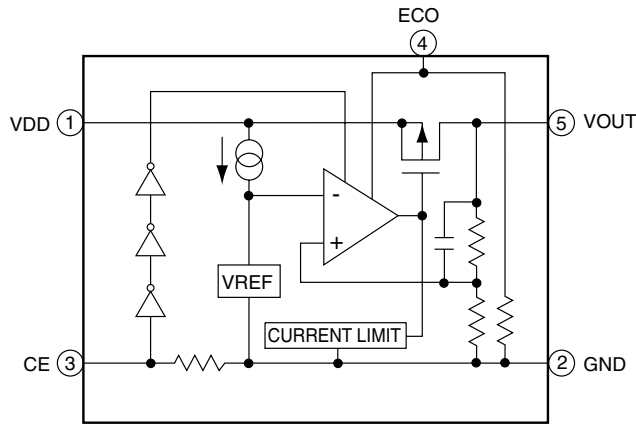

IC702 VHITK11131C-1R (TK11131C): REGULATOR

Pin No.	Terminal name	Input/Output	Description of terminal
1	CONT	Input	Control
2	GND	-	Ground
3	NP	Input	Capacitor (Vref)
4	VOUT	Output	Output
5	VIN	Input	Input

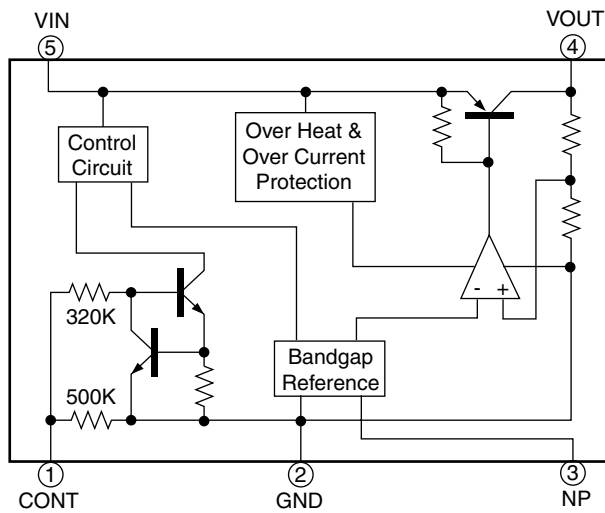

IC704 (LR38863): DISPLAY CONTROLLER

Pin No.	Terminal name	Input/Output	Description of terminal
1	DUMMY4	–	Dummy 4
2	VDDPLL	–	PLL Power supply 1.8 V (1.6 V~ 2.0 V)
3	PLLGND	–	PLL Ground
4	PLLDIV0	Input	PLL multiply switching signal
5	PLLDIV1	Input	PLL multiply switching signal
6	HSD0	Input/Output	Data bus for high-speed serial transfer
7	HSD1	Input/Output	Data bus for high-speed serial transfer
8	HSD2	Input/Output	Data bus for high-speed serial transfer
9	HSWRD	Input/Output	Read/Write determination signal for high-speed serial transfer
10	HSEN	Input/Output	High-speed serial data effective signal High is active
11	HSCK	Input/Output	Standard clock for high-speed serial transfer (5 to 33 MHz)
12	DUMMY3	–	Dummy 3
13*	PWM1/PORT8	Output	PWM output 1 General-purpose PORT output (default) (Not used)
14	PLLDIV2	Input	PLL multiply switching signal
15	VDDCORE	–	CORE Power supply 1.8 V (1.6 V~ 2.0 V)
16	GND	–	Logic ground
17	SUBWR_B	Input/Output	Light signal for External display
18	GND	–	Logic ground
19	VDDCORE	–	CORE Power supply 1.8 V (1.6 V~ 2.0 V)
20	PWM0/PORT3	Output	PWM output 0 General-purpose PORT output (default)
21	SUBCS_B	Input/Output	Chip select signal for External display
22	CS_B	Input/Output	Device select signal (Display is active when CS_B is "Low")
23	VDDIO	–	IO Power supply 3.0 V (2.7 V~ 3.3 V)
24	LCDINT	Output	External interrupt signal (Starting varies when interruption occurs.)
25	GTUDIO_B	Output	MPEG4ASIC internal core power-cut signal ("Low" is active.)
26	VDDIO	–	IO Power supply 3.0 V (2.7 V~ 3.3 V)
27	SUBDB1	Input/Output	Data bus for External display
28	BDATA[5] (B5)	Output	Display panel B output signa
29	BDATA[5] (B4)	Output	Display panel B output signa
30	BDATA[5] (B3)	Output	Display panel B output signa
31	GND	–	Logic ground
32	TESTI	Input	Test terminal (Connected to GND normally)
33	BSHS_B	Input/Output	External Bit Stream horizontal synchronization signal ("Low" is active)
34	WR_B	Input/Output	Host write strobe signal
35	SUBRS	Input/Output	Data determination signal for External display
36	MP4 RESET_B	Output	MPEG4ASIC reset control signal ("Low" is active)
37	HSD6	Input/Output	Data bus for high-speed serial transfer
38	BDATA[2] (B2)	Output	Display panel B output signal
39	BDATA[2] (B1)	Output	Display panel B output signal
40	BDATA[2] (B0)	Output	Display panel B output signal
41*	EXCS_B1	Input/Output	Chip select output 1 (internal decode output) (Not used)
42*	XOUT	Output	Oscillation circuit output (Not used)
43	VDDIO	–	IO Power supply 3.0 V (2.7 V~ 3.3 V)
44	GND	–	Logic ground
45	SCANEN	Input	Full scan effective signal "High" is active (Connected to GND normally)
46	RD_B	Input/Output	Host read strobe signal
47	RSP	Input/Output	Register selection signal HOST_IF section : RSP = Low...Display access RSP = High...Control access Hyper_Serial section : RSP = Low...Control acces RSP = High...Display access
48	GND	–	Logic ground
49	HSD3	Input/Output	Data bus for high-speed serial transfer
50	DCLK	Input/Output	Data sampling clock (display clock)
51	VSYNC	Input/Output	Vertical synchronization signal
52	HSYNC	Input/Output	Horizontal synchronization signal
53*	EXCS_B3	Input/Output	Chip select output 3 (internal decode output) (Not used)
54	XIN	Input	Oscillation circuit input/External clock input signal Clock input for full scan
55	SUBDB6	Input/Output	Data bus for External display
56	RESET_B	Input	Master reset (All registers are initialized when Low is activated)

Pin No.	Terminal name	Input/Output	Description of terminal
57	SUBDB0	Input/Output	Data bus for External display
58	SUBDB2	Input/Output	Data bus for External display
59	HSD5	Input/Output	Data bus for high-speed serial transfer
60	DB0	Input/Output	Data bus
61	HSD4	Input/Output	Data bus for high-speed serial transfer
62*	EXCS_B2	Input/Output	Chip select output 2 (internal decode output) (Not used)
63	GDATA[5] (G5)	Output	Display panel G output signal
64	GDATA[4] (G4)	Output	Display panel G output signal
65	GDATA[3] (G3)	Output	Display panel G output signal
66	SUBDB3	Input/Output	Data bus for External display
67	SUBDB4	Input/Output	Data bus for External display
68	HSD7	Input/Output	Data bus for high-speed serial transfer
69	DB1	Input/Output	Data bus
70	DB2	Input/Output	Data bus
71	DB3	Input/Output	Data bus
72	DB4	Input/Output	Data bus
73	STKCHK	Input	Setting BS-related output terminal to Hi-z when a stack is installed (Connected to GND normally)
74	VDDCORE	–	CORE Power supply 1.8 V (1.6 V~ 2.0 V)
75	GND	–	Logic ground
76	VDDIO	–	IO Power supply 3.0 V (2.7 V~ 3.3 V)
77	GDATA[2] (G2)	Output	Display panel G output signal
78	SUBDB5	Input/Output	Data bus for External display
79	BSCLK	Input/Output	External Bit Stream data clock
80	SUBCK	Output	Clock for External display
81	DB5	Input/Output	Data bus
82	VDDIO	–	IO Power supply 3.0 V (2.7 V~ 3.3 V)
83	GND	–	Logic ground
84	VDDCORE	–	CORE Power supply 1.8 V (1.6 V~ 2.0 V)
85	CAMCK	Output	Clock for camera operation
86	GDATA[1] (G1)	Output	Display panel G output signal
87	GDATA[0] (G0)	Output	Display panel G output signal
88	RDATA[5] (R5)	Output	Display panel R output signal
89	RDATA[4] (R4)	Output	Display panel R output signal
90	VDDCORE	–	CORE Power supply 1.8 V (1.6 V~ 2.0 V)
91*	PWMLCD/PORT4	Output	PWM LCD output General-purpose PORT output (default) (Not used)
92	BSBLK_B	Input/Output	External Bit Stream data effective signal (“High” is active when transferring the data)
93	DB6	Input/Output	Data bus
94	DB7	Input/Output	Data bus
95	DB8	Input/Output	Data bus
96	DB9	Input/Output	Data bus
97	VDDIO	–	IO Power supply 3.0 V (2.7 V~ 3.3 V)
98	RDATA[3] (R3)	Output	Display panel R output signal
99	RDATA[2] (R2)	Output	Display panel R output signal
100	RDATA[1] (R1)	Output	Display panel R output signal
101	RDATA[0] (R0)	Output	Display panel R output signal
102*	MP4_P0	Output	MPEG4 control
103*	EXCS_B0	Input/Output	Chip select output 0 (internal decode output) (Not used)
104	BSPIXEL7	Input/Output	External Bit Stream data bus
105	BSVS_B	Input/Output	External Bit Stream vertical synchronization signal (“Low” is active)
106	DB10	Input/Output	Data bus
107	DB11	Input/Output	Data bus
108	DB12	Input/Output	Data bus
109*	MP4_PLLCK	Output	MPEG4ASIC clock 15.36 MHz/CPU supply XIN clock (Not used)
110	SUBDB7	Input/Output	Data bus for External display
111	GND	–	Logic ground
112	DA0	Input/Output	Address input for chip select decode
113	BSPIXEL0	Input/Output	External Bit Stream data bus
114	DCS_B	Input	Chip select input dedicated for chip select decode
115	VDDIO	–	IO Power supply 3.0 V (2.7 V~ 3.3 V)
116	BSPIXEL6	Input/Output	External Bit Stream data bus
117	SE_DO/PORT0	Output	Data output for 4-wire serial IF (default) General-purpose PORT output
118	DB13	Input/Output	Data bus

Pin No.	Terminal name	Input/Output	Description of terminal
119	DB14	Input/Output	Data bus
120	DB15	Input/Output	Data bus
121	WAIT_B	Output	External wait signal ("Low" is active)
122	SUBFLMIN	Input	Driver FLM signal input for External display
123	SUBCKS	Output	Clock switching signal for External display
124	DA1	Input/Output	Address input for chip select decode
125	BSPIXEL1	Input/Output	External Bit Stream data bus
126	BSPIXEL4	Input/Output	External Bit Stream data bus
127	GND	–	Logic ground
128	BSPIXEL5	Input/Output	External Bit Stream data bus
129	SE_CK/PORT1	Output	Control clock for 4-wire serial IF (default) General-purpose PORT output
130	SE_LD2/PORT5	Output	Load signal 2 for 4-wire serial IF General-purpose PORT output (default)
131	BUFOFF_B	Input	Buffer Gated switching signal for I/O through current prevention (High when Host_IF signal is activated)
132	VDDIO	–	IO Power supply 3.0 V (2.7 V~ 3.3 V)
133	DUMMY2	–	Dummy 2
134*	SE_LD3/PORT6	Output	Load signal 3 for 4-wire serial IF General-purpose PORT output (default) (Not used)
135	VDDIO	–	IO Power supply 3.0 V (2.7 V~ 3.3 V)
136	SUBLPIN	Input	Driver LP input External display
137	BSPIXEL2	Input/Output	External Bit Stream data bus
138	BSPIXEL3	Input/Output	External Bit Stream data bus
139	VDDCORE	–	CORE Power supply 1.8 V (1.6 V~ 2.0 V)
140	SE_DI/PORT7	Input/Output	4-wire serial input (default) General-purpose PORT output
141	SE_LD1/PORT2	Output	Load signal 1 for 4-wire serial IF (default) General-purpose PORT output
142	GND	–	Logic ground
143	VDDCORE	–	CORE Power supply 1.8 V (1.6 V~ 2.0 V)
144	DUMMY1	–	Dummy 1 Dummy 4

In this unit, the terminal with asterisk mark (*) is (open) terminal which is not connected to the outside.

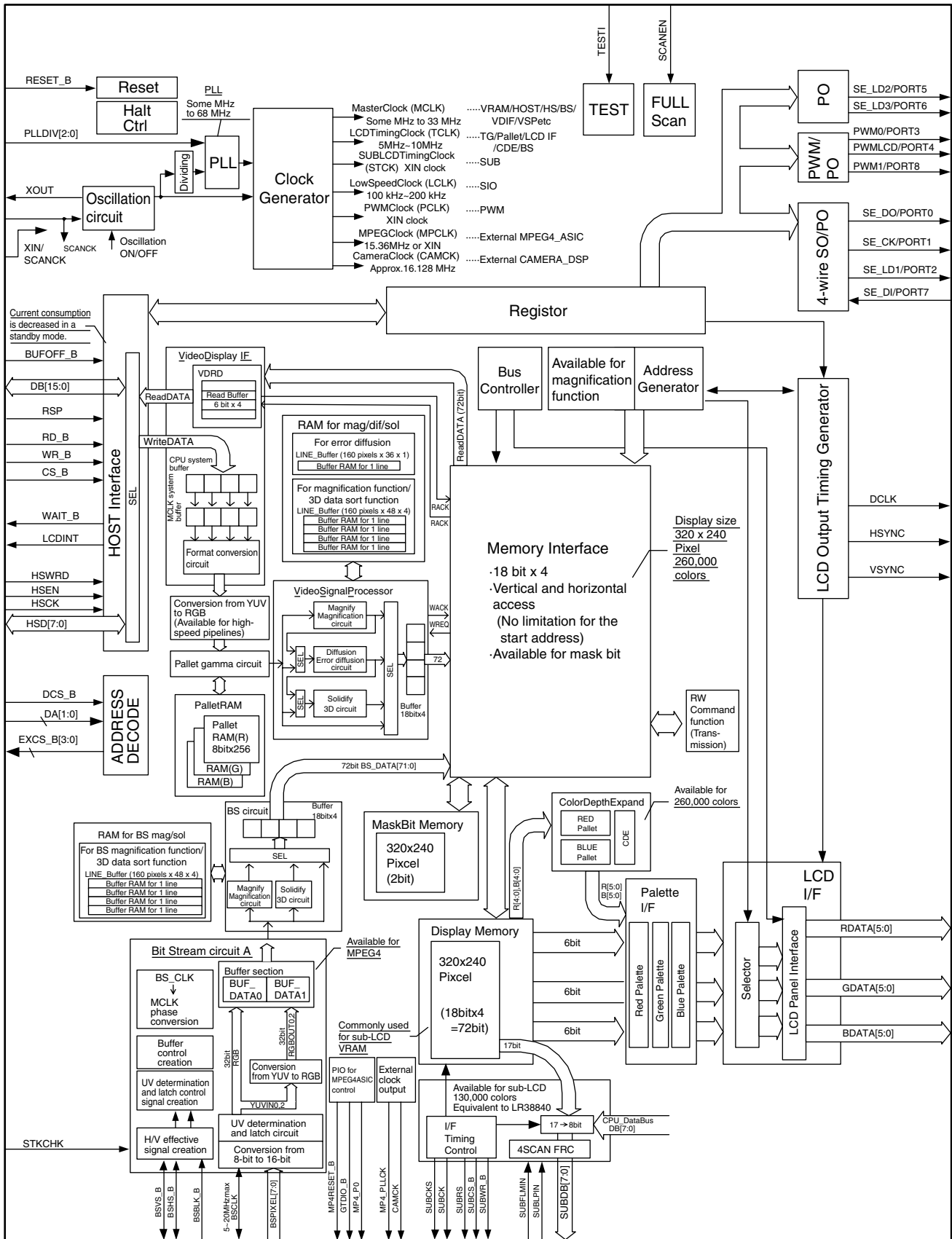

IC707 RH-IXA021AFZZL (BD6015): POWER MANAGEMENT

Pin No.	Terminal name	Input/Output	Input level	ESD Diode		Description of terminal	Initial status
				Power side	GND side		
1	T1	–	–	–	GND1	Dummy terminal (internally connected with T2)	–
2	LEDG	Output	–	–	GND1	Green LED drive output terminal (constant current drive)	LED off
3	GND1	–	–	VBAT1	–	Ground	–
4	VBAT1	–	–	–	GND1	VBAT power supply terminal	–
5*	LSO11	O, CMOS output	–	WVOUT	GND3	Level shift output 1 (Not used)	0 V output
6*	LSO12	O, CMOS output	–	WVOUT	GND3	Level shift output 1 (Not used)	0 V output
7	WVOUT	Output	–	–	GND3	2/4 times step-up charge pump output	Step-up stop
8	T2	–	–	–	GND1	Dummy terminal (internally connected with T1)	–
9	TEST	I, CMOS input	–	VBAT1	GND1	Test terminal (pulldown with IC, inside)	–
10	LEDR	Output	–	VBAT1	GND1	Red LED drive output terminal (constant current drive)	LED off
11	LEDB	Output	–	–	GND1	Blue LED drive output terminal (constant current drive)	LED off
12	TRSW	Output	–	VBAT1	GND1	DC-DC switching Tr drive terminal for R/G/B LED	Step-up stop
13	CAPP1	Output	–	WVOUT	GND3	2/4 times step-up charge pump C1 connection terminal	Step-up stop
14*	CAPN1	Output	–	WVOUT	GND3	2/4 times step-up charge pump C1 connection terminal (Not used)	Step-up stop
15	SENSP	Input	–	VBAT1	GND1	DC-DC switching current sense terminal for R/G/B LED	Step-up stop
16	SENSN	Input	–	VBAT1	GND1	DC-DC switching current sense terminal for R/G/B LED	Step-up stop
17	CAP3	Output	–	–	GND3	2/4 times step-up charge pump output terminal	Step-up stop
18	CPIN	Input	–	–	GND3	2/4 times step-up charge pump input terminal	–
19	CAPP2	Output	–	WVOUT	GND3	2/4 times step-up charge pump C2 connection terminal	Step-up stop
20	VIO	–	–	–	GND2	Logic system power supply terminal	–
21	VPLUS2	Input	–	–	GND1	DC-DC step-up voltage feedback input for R/G/B LED	Step-up stop
22*	CAPN2	Output	–	CPIN	GND3	2/4 times step-up charge pump C2 connection terminal (Not used)	Step-up stop
23	GND3	–	–	VBAT1	–	Ground	–
24	STRB	I, CMOS input	VIO	VIO	GND2	Three-wire serial strobe input	–
25	CLK	I, CMOS input	VIO	VIO	GND2	Three-wire serial clock input	–
26	VPLUS12	Input	–	–	GND3	DC-DC step-up voltage feedback input for front/rear backlights	Step-up stop
27	CAMP	Output	–	VPLUS12	GND3	+15 V voltage output terminal for camera	0 V output
28	DATA	I, CMOS input	VIO	VIO	GND2	Three-wire serial data input	–
29	FRP	I, CMOS input	VIO	VIO	GND2	Level shift circuit, rectangular wave input terminal	–
30	IREF	Output	–	VBAT1	GND3	Resistor connection terminal for current reference	–
31	VREF	Output	–	VBAT1	GND3	Voltage reference terminal (connected with C)	–
32	LEDCTL	I, CMOS input	VIO	VIO	GND2	On/Off control terminal for R/G/B LED	–
33*	ERROUT	Output	–	VBAT2	GND2	SWREG1 error detection amplifier output (Not used)	No output
34	FLED	Output	–	–	GND2	White LED drive terminal for front backlight	LED off
35	GND2	–	–	VBAT2	–	Ground	–
36	SBD	Input	–	–	GND2	SBD input terminal	–
37	VNEG	Input	–	VBAT1	–	Negative power supply terminal for camera	–
38	CAMN	Output	–	VBAT1	–	–8 V voltage output terminal for camera	0 V output
39	T4	–	–	–	GND3	Dummy terminal (internally connected with T3)	–
40	RSTB	I, CMOS input	VIO	VIO	GND2	Reset input (reset by low input)	–
41	BLED	Output	–	–	GND2	White LED drive terminal for rear backlight	LED off
42	SW	Output	–	–	GNDP	DC-DC coil switching terminal for front/rear backlights	Step-up stop
43	GNDP	Output	–	VBAT2	–	Ground	–
44	VBAT2	–	–	–	GND2	VBAT power supply	–
45	VPLUS11	Input	–	–	GND2	DC-DC step-up voltage feedback input for front/rear backlights	Step-up stop
46	T3	–	–	–	GND3	Dummy terminal (internally connected with T4)	–

In this unit, the terminal with asterisk mark (*) is (open) terminal which is not connected to the outside.

H	:T3	:VPLUS11	:VBAT2	:GNDP	:SW	:BLED	:RSTB	:T4
G	:CAMN	:VNEG	:SBD	:GND2	:FLED		:ERROUT	:LEDCTL
F	:VREF	:IREF					:FRP	:DATA
E	:CAMP	:VPLUS12					:CLK	:STRB
D	:GND3	:CAPN2					:VPLUS2	:VIO
C	:CAPP2	:CPIN				:CAP3		:SENSN
B	:CAPN1	:CAPP1			:TRSW	:LEDB	:LEDR	:TEST
A	:T2	:WVOUT	:LSO12	:LSO11	:VBAT1	:GND1	:LEDG	:T1
	8	7	6	5	4	3	2	1

IC708 VHITK11130C-1R (TK11130C): REGULATOR

Pin No.	Terminal name	Input/Output	Description of terminal
1	VCONT	Input	Control
2	GND	-	Ground
3	NP	-	Capacitor (Vref)
4	VOUT	Output	Output
5	VIN	Input	Input

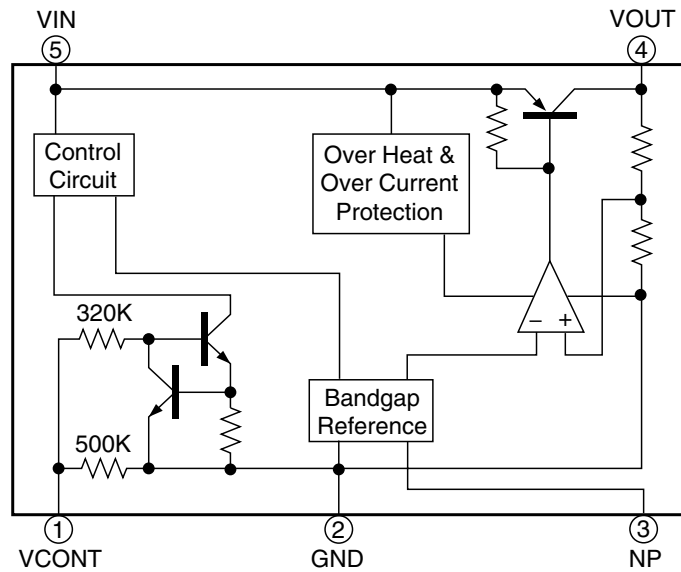

IC801 VH1HD155155-1L(HD155155NP): RF

Pin No.	Terminal name	Input/Output	Description of terminal
1	VCCLNA	Input	VCC for LNA transistor and LNA Bias
2	PCSGND	–	GND for Emitter of LNA transistor(PCS)
3	PCSLNAI	Input	Positive input for LNA transistor(PCS)
4	PCSLNAIB	Input	Negative input for LNA transistor(PCS)
5	PCSDCSGND	–	GND for Emitter of LNA transistor(PCS,DCS)
6	DCSLNAI	Input	Positive input for LNA transistor(DCS)
7	DCSLNAIB	Input	Negative input for LNA transistor(DCS)
8	DCSGSMGND	–	GND for Emitter of LNA transistor(DCS,GSM)
9	GSMLNAI	Input	Positive input for LNA transistor(GSM)
10	GSMLNAIB	Input	Negative input for LNA transistor(GSM)
11	GSMGND	–	GND for Emitter of LNA transistor(GSM)
12	PLLOUT	Output	Current output to control and modulate TXVCO
13	VCCOPLL	Input	VCC for OPLL and Phase comparator
14	VCCTXVCO	–	VCC for TXVCO
15	GNDTXVCO	–	GND for DCS/PCS TxVCO
16	GNDTXVCOB	–	GND for DCS/PCS TxVCO
17	TXOUTG	Output	Tx output for GSM
18	COMMONGND	–	GND for common
19	TXOUTD	Output	Tx output for DCS/PCS
20	TXVCOGB	Input	Negative TxVCO output for GSM
21	TXVCOG	Input	Positive TxVCO output for GSM
22	VCCIQ	Input	VCC for IQ modulator
23	IOUT/IIN	Input/Output	Positive output/input of I channel/modulator
24	IOUTB/IINB	Input/Output	Negative output/input of I channel/modulator
25	QOUT/QIN	Input/Output	Positive output/input of Q channel/modulator
26	QOUTB/QIN	Input/Output	Negative output/input of Q channel/modulator
27	VCCIFSYN	Input	VCC for IFVCO Buffer and Divider, and IF Synthesiser
28	CPIFSYN	Output	Charge Pump output of IF Synthesiser
29	LE	Input	Load enable for serial data
30	CLK	Input	Clock for serial data
31	VCXOOUT	Output	Output for VCXO
32	SDATA	Input	Serial Data
33*	GNDVCXO	–	GND for VCXO (Not used)
34*	VCXOE	–	Emitter of VCXO transistor (Not used)
35	VCXOB	Input	Base of VCXO transistor
36	VCCVCXO	Input	VCC for VCXO
37	VCCRFVCO	Input	VCC for RF Synthesiser
38	CPRFSYN	Output	Charge Pump output of RF Synthesiser
39	FLOCK	Output	FLOCK,Output,Fast Lock control for RF Synthesiser
40	VCCBB	Input	VCC for Base band and State Logic
41	VCCRFVCO	Input	VCC for RF VCO
42	DIVON	Output	VCXOOUT divider control input
43	VCCRFLO	Input	VCC for RF Local Buffer and Divider
44	CAPQB	Output	Capacitor for Q channel LPF(Negative output)
45	CAPQ	Output	Capacitor for Q channel LPF(Positive output)
46	CAPIB	Output	Capacitor for I channel LPF(Negative output)
47	CAPI	Output	Capacitor for I channel LPF(Positive output)
48	VCCMIX	Input	VCC for Direct conversion Mixer
49	GNDLNA	–	GND for LNA Bias

In this unit, the terminal with asterisk mark (*) is (open) terminal which is not connected to the outside.

IC802 VH1PF08141B-1L(PF08141B): PA MODULE

Pin No.	Terminal name	Input/Output	Description of terminal
1	Pin_GSM850/900	Input	Input power from TXVCO (GSM850/900)
2	Vband	Input	Band select voltage
3	Vdd IC	Input	Input,Power supply
4	GND	-	Ground
5	GND	-	Ground
6	Vdd1	Input	Power supply
7	Pout_GSM850/900	Output	Output power (GSM850/900)
8	GND	-	Ground
9	GND	-	Ground
10	GND	-	Ground
11	GND	-	Ground
12	PoutDCS1800/1900	Output	Output power (DCS/PCS)
13	Vdd2	Input	Power supply
14	GND	-	Ground
15	GND	-	Ground
16	Vtxb	Input	Txon Voltage
17	Vramp	Input	Power control voltage
18	Pin_DCS1800/1900	Input	Input power from TXVCO (DCS/PCS)
19	GND	-	Ground
20	GND	-	Ground
21	GND	-	Ground
22	GND	-	Ground
23	GND	-	Ground
24	GND	-	Ground
25	GND	-	Ground
26	GND	-	Ground
27	GND	-	Ground
28	GND	-	Ground
29	GND	-	Ground

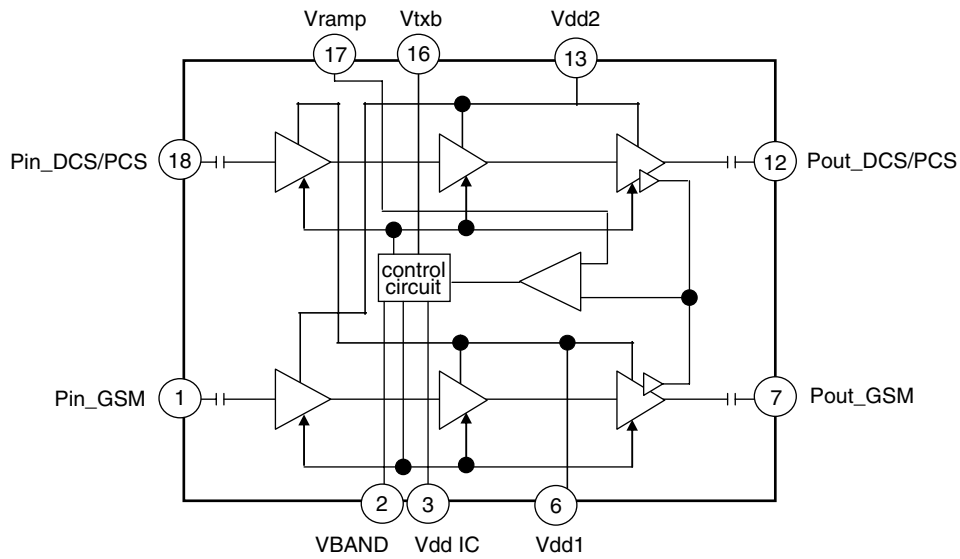

IC804 VHIR5322N29-1L(R5322N002B): POWER SUPPLY

Pin No.	Terminal name	Input/Output	Description of terminal
1	CE1	Input	Chip Enable1
2	VDD	Input	Power supply
3	CE2	Input	Chip Enable2
4	VOUT2	Output	VCC for VRF
5	GND	–	Ground
6	VOUT1	Output	VCC for VTCXO

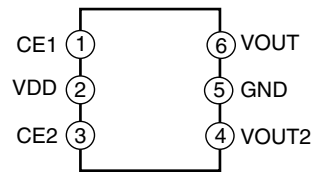
**IC805 VHINL17SZ32-1L(NL17SZ32XV5T2): LOGIC**

Pin No.	Terminal name	Input/Output	Description of terminal
1	VIN1	Input	Input power
2	VIN2	Input	Input power
3	GND	–	Ground
4	VOUT	Output	Logic value output
5	VCC	Input	VCC for VRF

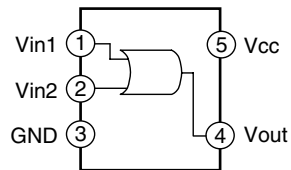

[2] Function table of Camera

CA1001 DKENDW108AFSN: CAMERA UNIT

Pin No.	Terminal name	Input/Output	Description of terminal
1	A1	Input	Address signal
2	A2	Input	Address signal
3	A17	Input	Address signal
4	A18	Input	Address signal
5	A19	Input	Address signal
6	OD15	Input/Output	Data bus signal 15
7	OD14	Input/Output	Data bus signal 14
8	OD13	Input/Output	Data bus signal 13
9	OD12	Input/Output	Data bus signal 12
10	OD11	Input/Output	Data bus signal 11
11	OD10	Input/Output	Data bus signal 10
12	OD9	Input/Output	Data bus signal 9
13	OD8	Input/Output	Data bus signal 8
14	OD7	Input/Output	Data bus signal 7
15	OD6	Input/Output	Data bus signal 6
16	OD5	Input/Output	Data bus signal 5
17	OD4	Input/Output	Data bus signal 4
18	OD3	Input/Output	Data bus signal 3
19	OD2	Input/Output	Data bus signal 2
20	OD1	Input/Output	Data bus signal 1
21	OD0	Input/Output	Data bus signal 0
22	RSTN	Input	Reset signal
23	VDD1	—	Power supply input (2.5 V/DSP core)
24	GND	—	Ground
25	GND	—	Ground
26	GND	—	Ground
27	GND	—	Ground
28	GND	—	Ground
29	GND	—	Ground
30	GND	—	Ground
31	GND	—	Ground
32	AVDD	—	Power supply input (+3.1 V/DSP analog)
33	VDD5	—	Power supply input (+2.9 V/For YUV output buffer)
34	VDD2	—	Power supply input (+3.1 V/I/O)
35	VDD6	—	Power supply input (+3.3 V/V-Driver)
36	VDD4	—	Power supply input (–8 V/Sensor)
37	RDB	Input	IP parameter read signal
38	EXCKI	Input	External clock input
39	CSB	Input	Chip select input
40	WRB	Input	IP parameter write signal
41	CINT	Output	Interruption signal
42	VDD3	—	Power supply input (+15 V/Sensor)

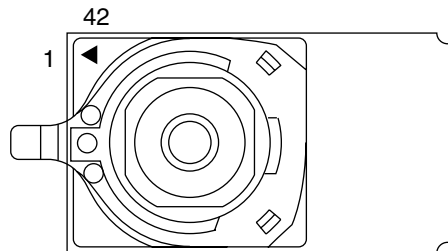

[3] Function table of Display

LCD1000 RLCUB0048AF03: MAIN DISPLAY

Pin No.	Terminal name	Input/Output	Description of terminal
1	T-COM	Input	COM electric potential input for CS
2	T-COM	Input	COM electric potential input for CS
3	TFT-COM	Input	COM voltage input
4	COMC	Output	COM signal output
5	COMC	Output	COM signal output
6	COMDC	Output	COM center voltage output
7	VCOMH	Output	COM amplitude voltage output
8	B0	Input	Blue data signal (LSB)
9	B1	Input	Blue data signal
10	B2	Input	Blue data signal
11	B3	Input	Blue data signal
12	B4	Input	Blue data signal
13	B5	Input	Blue data signal (MSB)
14	G0	Input	Green data signal (LSB)
15	G1	Input	Green data signal
16	G2	Input	Green data signal
17	G3	Input	Green data signal
18	G4	Input	Green data signal
19	G5	Input	Green data signal (MSB)
20	R0	Input	Red data signal (LSB)
21	R1	Input	Red data signal
22	R2	Input	Red data signal
23	R3	Input	Red data signal
24	R4	Input	Red data signal
25	R5	Input	Red data signal (MSB)
26	DCLK	Input	Data sampling clock
27	HSY	Input	Horizontal sync signal
28	VSX	Input	Vertical sync signal
29	SO	Output	serial data output
30	SI	Input	serial data input
31	SCLK	Input	serial clock input
32	CS	Input	serial interface chip select
33	RESET	Input	Hardware reset
34	VCC	-	Logic power
35	GND	-	Ground
36	GND	-	Ground
37	VDC	-	Analog power
38	VDC	-	Analog power
39	COM2	-	COM control for CS
40	VCLAMP	Output	Voltage for CS output
41	VSS2	Output	DC/DC converter output
42	VSS1	Output	DC/DC converter output
43*	NC	-	Not used
44	VDD2	Output	DC/DC converter output
45	C5-	-	Booster capacitor connection terminal
46	C5+	-	Booster capacitor connection terminal
47	C4-	-	Booster capacitor connection terminal
48	C4+	-	Booster capacitor connection terminal
49	C3-	-	Booster capacitor connection terminal
50	C3+	-	Booster capacitor connection terminal
51	C2-	-	Booster capacitor connection terminal
52	C2+	-	Booster capacitor connection terminal
53	C1-	-	Booster capacitor connection terminal
54	C1+	-	Booster capacitor connection terminal
55	VDC2	Output	DC/DC converter output
56	VDC2	Output	DC/DC converter output
57	VR	Output	Reference power supply output
58	VS	Output	Source power supply output
59	VS	Output	Source power supply output

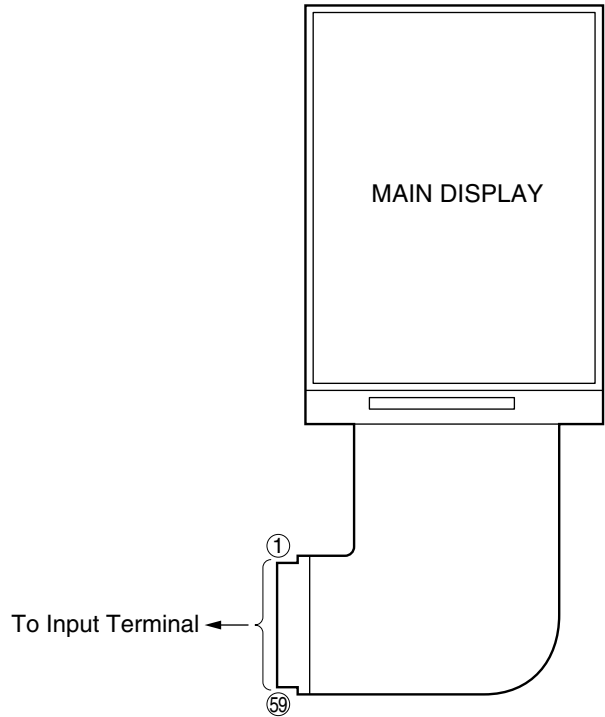

In this unit, the terminal with asterisk mark (*) is (open) terminal which is not connected to the outside.

LCD001 RLCUB0049AFZZ : EXTERNAL DISPLAY

Pin No.	Terminal name	Input/Output	Description of terminal	Notes
1	V0	–	Display drive power supply terminal	–
2	V1	–	Display drive power supply terminal	–
3	V2	–	Display drive power supply terminal	–
4	V3	–	Display drive power supply terminal	–
5	V4	–	Display drive power supply terminal	–
6	GND	–	Ground	–
7	RESB	Input	Reset signal	–
8	CSB	Input	Chip select signal	–
9	RS	Input	Register select signal	"0": Display RAM data "1": Command data
10	WRB	Input	Write signal	"L": Activated
11	RDB	Input	Read signal	"L": Activated
12	D0	Input/Output	Data signal	–
13	D1	Input/Output	Data signal	–
14	D2	Input/Output	Data signal	–
15	D3	Input/Output	Data signal	–
16	D4	Input/Output	Data signal	–
17	D5	Input/Output	Data signal	–
18	D6	Input/Output	Data signal	–
19	D7	Input/Output	Data signal	–
20	LP	Input/Output	Latch signal	–
21	FLM	Output	Display sync signal	–
22	GND (VSS)	–	Ground	–
23	CK	Input	Master clock external input terminal	–
24	CKS	Input	Master clock input selection terminal	"L": Built-in oscillation
25	VDD/VEE	–	Logic system power supply terminal	–
26	VREG	Output	Output terminal for generating constant voltage	–
27	VOUT	Output	Built-in step-up circuit output terminal	–
28	CAP1–	Output	Booster capacitor connection terminal (–)	–
29	CAP1+	Output	Booster capacitor connection terminal (+)	–
30	CAP2–	Output	Booster capacitor connection terminal (–)	–
31	CAP2+	Output	Booster capacitor connection terminal (+)	–
32	CAP3–	Output	Booster capacitor connection terminal (–)	–
33	CAP3+	Output	Booster capacitor connection terminal (+)	–

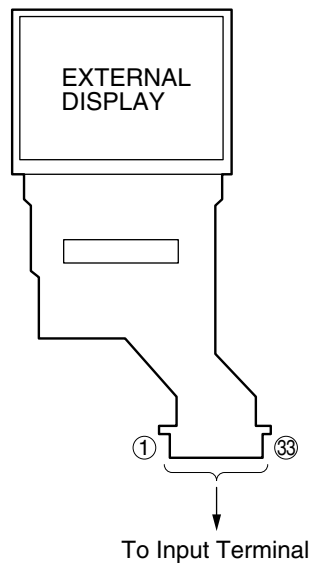

SHARP PARTS GUIDE

No. S5409TQGX30/B

DIGITAL MOBILE PHONE MODEL GX30

CONTENTS

- | | |
|-------------------------|-----------------------------------|
| [1] INTEGRATED CIRCUITS | [9] ARRAY PARTS |
| [2] TRANSISTORS | [10] CAPACITORS |
| [3] DIODES | [11] RESISTORS |
| [4] FILTERS | [12] OTHER CIRCUITRY
PARTS |
| [5] COILS | [13] CABINET PARTS |
| [6] VARIABLE RESISTORS | [14] ACCESSORIES/PACKING
PARTS |
| [7] VIBRATORS | [15] P.W.B. ASSEMBLY |
| [8] THERMISTOR | |

Parts marked with "△" are important for maintaining the safety of the set. Be sure to replace these parts with specified ones for maintaining the safety and performance of the set.

NO.	PARTS CODE	PRICE RANK	NEW MARK	PART RANK	DESCRIPTION
[1] INTEGRATED CIRCUITS					
	iC101	-----	--		This Parts is Supplied with Cabinet Parts 104
	iC103	-----	--		This Parts is Supplied with Cabinet Parts 104
△	iC105	VHiYMU762C+-1L	AX		Sound,YMU762C
△	iC106	-----	--		This Parts is Supplied with Cabinet Parts 104
	iC107	VHiEW6671+-1R	AD		Hall,EW6671
	iC108	VHiR3112Q26-1L	AD		Voltage Detector,R3112Q261A
	iC109	VHiNJ287130-1L	AE		3.0V Regulator,NJM2871F03
	iC111	VHiR116030B-1L	AE		Regulator,R1160N301B
	iC113	VHiTC7SZ08A-1L	AD		And Gate,TC7SZ08A
	iC114	RH-iXA007AFZZL	AE		Comparator,HA1631S03CME
	iC115	VHiXC61CN27-1L	AD		Regulator,XC61CN27
	iC116	VHiRQ5RW45B-1L	AD		4.5V Regulator,RQ5RW45B
	iC502	VHiBU7870KN-1L	AM		USB CONTROLLER,BU7870KN
	iC503	VHiTK73840B-1L	AF		Regulator,TK73840B
	iC504	VHiUSBUF2W6-1L	AF		USB EMI Filter,USBUF2W6
	iC505	VHiXC620930-1L	AD		Regulator,XC620930
	iC506	RUNTZA005AFZZL	BC		Bluetooth Module,UGNZ2
	iC507	VHiTC7SET00FU-	AC		Logic,TC7SET00FU
	iC508	VHi817A30NB-1R	AD		3.0V Regulator,817A30NB
	iC509	VHiLVC2G34P-1R	AD		Buffer,LVC2G34P
	iC701	VHiR116025B-1L	AE		2.5V Regulator,R116025B
	iC702	VHiTK11131C-1R	AD		Regulator,TK11131C
	iC703	VHiR116018B-1L	AE		1.8V Regulator,R116018B
	iC704	-----	--		This Parts is Supplied with Cabinet Parts 104
	iC706	VHiTC7SZ08A-1L	AD		Logic,TC7SZ08A
	iC707	RH-iXA021AFZZL	AS		Power Management,BD6015
	iC708	VHiTK11130C-1R	AE		Regulator,TK11130C
△	iC801	VHiHD155155-1L	AV		RF,HD155155NP
△	iC802	VHiPF08141B-1L	AV		PA Module,PF08141B
	iC804	VHiR5322N29-1L	AF		Power Supply,R5322N002B
	iC805	VHiNL17SZ32-1L	AC		Logic,NL17SZ32XV5T2
[2] TRANSISTORS					
	Q101	VS2SK3019//--1+	AC		FET,2SK3019
	Q103	VSCPH6311+-1R	AE		FET,CPH6311
	Q104	VSEMD6++++-1R	AC		Digital,PNP/NPN,EMD6
	Q106	VSEC4301C+-1L	AB		FET,EC4301 C
	Q107	VSEC4401C+-1L	AB		FET,EC4401 C
	Q108	VSECH8603+-1L	AF		FET,ECH8603
	Q501	VSRT1N144U/-1+	AB		Digital,NPN,RT1N144 U
	Q503	VSRT1N144U/-1+	AB		Digital,NPN,RT1N144 U
	Q504	VSEC4301C+-1L	AB		FET,EC4301 C
	Q505	VSEC4401C+-1L	AB		FET,EC4401 C
	Q702	VSMCH6413+-1R	AD		FET,MCH6413
[3] DIODES					
	D103	VHDRB160M30-1L	AC		Silicon,RB160M30
	D105	VHD1SS388//--1+	AB		Silicon,1SS388
	D106	VHDRB521S30-1-	AB		Silicon,RB521S30
	D503	VHDRB160M30-1L	AC		Silicon,RB160M30
	D504	VHDHN2S01FU-1L	AD		Silicon,HN2S01FU
	D505	VHDHN2S01FU-1L	AD		Silicon,HN2S01FU
	D701	VHDMA2SD32+-1L	AB		Silicon,MA2SD32
	D702	VHDMA2SD31+-1L	AB		Silicon,MA2SD31
	D703	VHDRB551V30-1-	AC		Silicon,RB551V30
	D704	VHDMA2SD31+-1L	AB		Silicon,MA2SD31
	D705	VHDMA2SD31+-1L	AB		Silicon,MA2SD31
	D709	VHDRB521S30-1-	AB		Silicon,RB521S30
	D710	VHD1SS405+-1L	AC		Silicon,1SS405
	LED103	VHPYPY1105C-1L	AC		LED,Green,YPY1105C
	LED104	VHPYPY1105C-1L	AC		LED,Green,YPY1105C
	LED106	VHPYPY1105C-1L	AC		LED,Green,YPY1105C
	LED107	VHPYPY1105C-1L	AC		LED,Green,YPY1105C
	LED109	VHPYPY1105C-1L	AC		LED,Green,YPY1105C
	LED110	VHPYPY1105C-1L	AC		LED,Green,YPY1105C
	LED111	VHPYPY1105C-1L	AC		LED,Green,YPY1105C
	LED112	VHPYPY1105C-1L	AC		LED,Green,YPY1105C
	LED117	VHPYPY1105C-1L	AC		LED,Green,YPY1105C
	LED118	VHPYPY1105C-1L	AC		LED,Green,YPY1105C
	LED119	VHPYPY1105C-1L	AC		LED,Green,YPY1105C
	LED120	VHPYPY1105C-1L	AC		LED,Green,YPY1105C
	LED702	VHPGM56271A-1L	AS		LED,Red/Blue/Green,GM56271A
	LED703	VHPNECW008A-1L	AH		LED,White,NECW008A
	LED704	VHPNECW008A-1L	AH		LED,White,NECW008A
	UN101	VHPGP2W0116-1R	AK		Infrared Port
	ZD101	VHERSB6R8S+-1L	AC		Zener,6.8V,RSB6.8S
	ZD104	VHERSB6R8S+-1L	AC		Zener,6.8V,RSB6.8S

NO.	PARTS CODE	PRICE RANK	NEW MARK	PART RANK	DESCRIPTION
[4] FILTERS					
FL101	RFiLNA004AFZZN	AC			Noise Filter
FL102	RFiLNA004AFZZN	AC			Noise Filter
FL103	RFiLNA004AFZZN	AC			Noise Filter
FL104	RFiLNA004AFZZN	AC			Noise Filter
FL701	RFiLNA004AFZZN	AC			Noise Filter
FL803	RFiLRA006AFZZL	AF			RF Switch
FL823	RFiLNO020AFZZN	AB			Ferrite Beads
FL901	RFiLRA004AFZZL	AF			SAW Filter
FL902	RFiLRA003AFZZL	AH			SAW Filter
FL903	RFiLRA005AFZZL	AF			SAW Filter
FL904	RFiLRA007AFZZL	AF			Matching Device
FL905	RFiLR0256AFZZL	AE			ESD Device
[5] COILS					
L101	RCiLZ1088YCZZ-	AC			Ferrite Beads
L102	RCiLZ1088YCZZ-	AC			Ferrite Beads
L103	RCiLZ0315AFZZT	AB			Ferrite Beads
L105	RCiLZ0315AFZZT	AB			Ferrite Beads
L106	RCiLZ0370AFZZN	AB			60 ohms (100MHz)
L107	RCiLZ1088YCZZ-	AC			Ferrite Beads
L108	RCiLZ1088YCZZ-	AC			Ferrite Beads
L113	RCiLZ1088YCZZ-	AC			Ferrite Beads
L221	RCiLZ0387AFZZN	AB			Ferrite Beads
L223	RCiLZ0387AFZZN	AB			Ferrite Beads
L701	RCiLC0385AFZZL	AC			4.7 μ H
L702	RCiLC0385AFZZL	AC			4.7 μ H
L714	RCiLZ0370AFZZN	AB			60 ohms (100MHz)
L715	RCiLZ0370AFZZN	AB			60 ohms (100MHz)
L746	RCiLZA008AFZZN	AB			Ferrite Beads
L749	RCiLZ0387AFZZN	AB			Ferrite Beads
L801	RCiLZ1103YCZZ-	AB			Ferrite Beads
L802	RCiLZA005AFZZN	AB			Ferrite Beads
L803	VPCAMT27S0000-	AC			2.7 nH
L804	VPCAMT27S0000-	AC			2.7 nH
L805	VPCAMT12S0000-	AB			1.2 nH
L806	VPCAMT12S0000-	AB			1.2 nH
L809	VPCAMT68J0000-	AA			6.8 nH
L821	VPCAMT22S0000-	AC			2.2 nH
L822	VPCAMT22S0000-	AC			2.2 nH
L834	VPCAMT68J0000-	AA			6.8 nH
L871	VPCAMT33S0000-	AA			3.3 nH
L872	VPCAMT33S0000-	AA			3.3 nH
[6] VARIABLE RESISTORS					
V101	VHV10080MBB-1N	AB			Varistor,100 pF,8V
V102	VHV10080MBB-1N	AB			Varistor,100 pF,8V
V103	VHV10080MBB-1N	AB			Varistor,100 pF,8V
V104	VHV10080MAB-1N	AB			Varistor,650 pF,8V
V106	VHV10080MAB-1N	AB			Varistor,650 pF,8V
V109	VHV10080MAB-1N	AB			Varistor,650 pF,8V
V124	VHV10080MAB-1N	AB			Varistor,650 pF,8V
V501	VHV10080MBB-1N	AB			Varistor,100 pF,8V
V504	VHV10080MBB-1N	AB			Varistor,100 pF,8V
V505	VHV10080MBB-1N	AB			Varistor,100 pF,8V
V512	VHV10270MBB-1N	AB			Varistor,15 pF,27V
V513	VHV10080MBB-1N	AB			Varistor,100 pF,8V
V514	VHV10270MBB-1N	AB			Varistor,15 pF,27V
V555	VHV10270MBB-1N	AB			Varistor,15 pF,27V
[7] VIBRATORS					
TCX801	RTCXA002AFZZL	AN			VCTCXO,26 MHz
X101	RCRSC0065AFZZL	AF			Crystal,32 kHz
[8] THERMISTOR					
TH101	RH-HXA001AFZZN	AF			Thermistor,10 kohm
TH701	RH-HXA001AFZZN	AF			Thermistor,10 kohm
[9] ARRAY PARTS					
FL204	RFiLNO024AFZZR	AF			Array,EMI Filter
FL205	RFiLNO024AFZZR	AF			Array,EMI Filter
FL206	RFiLNO024AFZZR	AF			Array,EMI Filter
FL207	RFiLNO024AFZZR	AF			Array,EMI Filter
FL208	RFiLNO024AFZZR	AF			Array,EMI Filter
L709	RCiLZ0376AFZZN	AD			Array,Ferrite Beads
L710	RCiLZ0376AFZZN	AD			Array,Ferrite Beads
L711	RCiLZ0376AFZZN	AD			Array,Ferrite Beads
L733	RCiLZ0376AFZZN	AD			Array,Ferrite Beads
L734	RCiLZ0376AFZZN	AD			Array,Ferrite Beads
L735	RCiLZ0376AFZZN	AD			Array,Ferrite Beads
L736	RCiLZ0376AFZZN	AD			Array,Ferrite Beads
R273	RMPTR4470ACZZN	AB			Array,47 ohms
R274	RMPTR4470ACZZN	AB			Array,47 ohms
R275	RMPTR4470ACZZN	AB			Array,47 ohms
R276	RMPTR4470ACZZN	AB			Array,47 ohms

NO.	PARTS CODE	PRICE RANK	NEW MARK	PART RANK	DESCRIPTION
[10] CAPACITORS					
C101	VCCCCZ1EH470JT	AB			47 pF (CH),25V
C103	VCKYCZ1AB104KT	AA			0.1 μ F,10V
C104	VCCCCZ1EH470JT	AB			47 pF (CH),25V
C105	VCKYCZ1AB104KT	AA			0.1 μ F,10V
C107	VCSAPR0GJ226M-	AD			22 μ F,4V
C108	RC-KZ1315AFZZN	AC			10 μ F,6.3V
C110	VCSAPR0GJ226M-	AD			22 μ F,4V
C112	VCCCCZ1EH470JT	AB			47 pF (CH),25V
C113	VCKYCZ1EB102KT	AB			0.001 μ F,25V
C115	VCCCCZ1EH470JT	AB			47 pF (CH),25V
C116	VCCCCZ1EH470JT	AB			47 pF (CH),25V
C116A	VCKYCZ0JB105KT	AB			1 μ F,6.3V
C117	VCKYCZ1EB102KT	AB			0.001 μ F,25V
C118	VCKYCZ1AB104KT	AA			0.1 μ F,10V
C120	VCCCCZ1EH470JT	AB			47 pF (CH),25V
C120A	VCKYCZ0JB105KT	AB			1 μ F,6.3V
C121	VCCCCZ1EH470JT	AB			47 pF (CH),25V
C122	VCCCCZ1EH470JT	AB			47 pF (CH),25V
C126	VCKYCZ1AB104KT	AA			0.1 μ F,10V
C127	VCKYCZ1AB104KT	AA			0.1 μ F,10V
C132	VCCCCZ1EH470JT	AB			47 pF (CH),25V
C133	VCCCCZ1EH470JT	AB			47 pF (CH),25V
C134	VCCCCZ1EH470JT	AB			47 pF (CH),25V
C139	VCKYCZ1AB104KT	AA			0.1 μ F,10V
C141	VCKYCZ1EB472KT	AB			0.0047 μ F,25V
C142	VCKYCY1AB105KT	AB			1 μ F,10V
C143	VCKYCZ1AB104KT	AA			0.1 μ F,10V
C144	RC-KZ1315AFZZN	AC			10 μ F,6.3V
C145	VCKYCZ1AB104KT	AA			0.1 μ F,10V
C146	VCKYCZ1AB104KT	AA			0.1 μ F,10V
C147	VCKYCZ1AB104KT	AA			0.1 μ F,10V
C148	VCKYCZ1AB473KT	AB			0.047 μ F,10V
C149	RC-KZ1308AFZZT	AD			4.7 μ F,6.3V
C150	VCKYCZ0JB105KT	AB			1 μ F,6.3V
C151	VCKYCZ1EB102KT	AB			0.001 μ F,25V
C152	VCKYCZ1AB104KT	AA			0.1 μ F,10V
C153	VCKYCY1AB104KT	AC			0.1 μ F,10V
C154	VCCCCZ1EH221JT	AA			220 pF (CH),25V
C155	VCKYCZ0JB105KT	AB			1 μ F,6.3V
C157	VCKYCZ1AB473KT	AB			0.047 μ F,10V
C158	VCKYCY0JB225KT	AC			2.2 μ F,6.3V
C159	VCKYCZ0JB105KT	AB			1 μ F,6.3V
C160	VCKYCZ0JB105KT	AB			1 μ F,6.3V
C161	VCKYCZ0JB105KT	AB			1 μ F,6.3V
C162	VCKYCY1AB474KT	AC			0.47 μ F,10V
C163	VCKYCZ0JB105KT	AB			1 μ F,6.3V
C164	VCKYCZ0JB105KT	AB			1 μ F,6.3V
C165	VCKYCZ1AB104KT	AA			0.1 μ F,10V
C166	VCKYCY1AB105KT	AB			1 μ F,10V
C167	RC-KZ1308AFZZT	AD			4.7 μ F,6.3V
C168	VCKYCZ1AB104KT	AA			0.1 μ F,10V
C169	VCKYCZ1AB104KT	AA			0.1 μ F,10V
C170	VCKYCZ1AB104KT	AA			0.1 μ F,10V
C171	VCKYCZ1EB102KT	AB			0.001 μ F,25V
C173	VCKYCZ1EB102KT	AB			0.001 μ F,25V
C176	VCCCCZ1EH2R0CT	AB			2 pF (CH),25V
C177	VCKYCZ1AB104KT	AA			0.1 μ F,10V
C178	VCKYCZ1AB104KT	AA			0.1 μ F,10V
C179	VCKYCZ1AB104KT	AA			0.1 μ F,10V
C180	VCKYCZ1AB104KT	AA			0.1 μ F,10V
C181	VCKYCZ1AB104KT	AA			0.1 μ F,10V
C182	VCKYCZ1AB104KT	AA			0.1 μ F,10V
C183	VCKYCZ1AB104KT	AA			0.1 μ F,10V
C184	VCKYCZ1AB104KT	AA			0.1 μ F,10V
C185	VCKYCZ1AB104KT	AA			0.1 μ F,10V
C186	VCKYCZ1AB104KT	AA			0.1 μ F,10V
C187	VCKYCZ1AB104KT	AA			0.1 μ F,10V
C188	VCKYCZ1AB104KT	AA			0.1 μ F,10V
C189	VCKYCZ1AB104KT	AA			0.1 μ F,10V
C190	VCKYCZ1AB104KT	AA			0.1 μ F,10V
C191	VCKYCZ1AB104KT	AA			0.1 μ F,10V
C192	VCCCCZ1EH470JT	AB			47 pF (CH),25V
C193	VCKYCZ1AB104KT	AA			0.1 μ F,10V
C194	VCKYCZ1AB104KT	AA			0.1 μ F,10V
C196	RC-KZ1308AFZZT	AD			4.7 μ F,6.3V
C197	RC-KZ1308AFZZT	AD			4.7 μ F,6.3V
C198	VCKYCZ1AB104KT	AA			0.1 μ F,10V
C199	VCKYCZ1AB104KT	AA			0.1 μ F,10V
C200	VCKYCZ1AB104KT	AA			0.1 μ F,10V
C205	VCKYCZ1CB103KT	AB			0.01 μ F,16V
C206	RC-KZ1315AFZZN	AC			10 μ F,6.3V
C207	VCKYCZ1AB104KT	AA			0.1 μ F,10V
C208	VCKYCZ1AB104KT	AA			0.1 μ F,10V
C210	VCKYCZ1AB104KT	AA			0.1 μ F,10V
C213	VCKYCZ0JB105KT	AB			1 μ F,6.3V

NO.	PARTS CODE	PRICE RANK	NEW MARK	PART RANK	DESCRIPTION
[10] CAPACITORS					
C214	VCKYCZ0JB105KT	AB			1 μ F,6.3V
C215	VCKYCZ1AB104KT	AA			0.1 μ F,10V
C216	VGCCZ1EH270JT	AA			27 pF (CH),25V
C217	VGCCZ1EH120JT	AB			12 pF (CH),25V
C218	VGCCZ1EH270JT	AA			27 pF (CH),25V
C219	VCKYCZ1AB104KT	AA			0.1 μ F,10V
C220	VCKYCZ1AB104KT	AA			0.1 μ F,10V
C221	VCKYCZ1AB104KT	AA			0.1 μ F,10V
C222	VCKYCZ1AB104KT	AA			0.1 μ F,10V
C223	VCKYCZ0JB105KT	AB			1 μ F,6.3V
C224	VCKYCZ1AB104KT	AA			0.1 μ F,10V
C226	VCKYCZ1AB473KT	AB			0.047 μ F,10V
C227	VCKYCZ0JB105KT	AB			1 μ F,6.3V
C228	VCKYCY0JB225KT	AC			2.2 μ F,6.3V
C229	VCKYCZ1EB102KT	AB			0.001 μ F,25V
C231	VGCCZ1EH470JT	AB			47 pF (CH),25V
C232	VGCCZ1EH470JT	AB			47 pF (CH),25V
C235	VCKYCY1AB105KT	AB			1 μ F,10V
C236	VCKYCZ0JB105KT	AB			1 μ F,6.3V
C504	VCKYCZ1EB102KT	AB			0.001 μ F,25V
C505	RC-KZ1321AFZZN	AD			22 μ F,6.3V
C506	VCKYCZ1AB104KT	AA			0.1 μ F,10V
C507	VCKYCZ0JB105KT	AB			1 μ F,6.3V
C508	VCKYCZ1AB104KT	AA			0.1 μ F,10V
C509	VCKYCZ1AB104KT	AA			0.1 μ F,10V
C510	VCKYCZ0JB105KT	AB			1 μ F,6.3V
C511	VCKYCY1CB103KT	AB			0.01 μ F,16V
C512	VCKYCY1AB105KT	AB			1 μ F,10V
C516	VCKYCY1AB105KT	AB			1 μ F,10V
C518	VCKYCZ1AB104KT	AA			0.1 μ F,10V
C522	RC-KZ1319AFZZN	AC			2.2 μ F,25V
C523	VCKYCZ0JB105KT	AB			1 μ F,6.3V
C524	VCKYCZ0JB105KT	AB			1 μ F,6.3V
C525	VCKYCZ1AB104KT	AA			0.1 μ F,10V
C701	RC-KZ1308AFZZT	AD			4.7 μ F,6.3V
C702	VCKYCY1EB474KT	AB			0.47 μ F,25V
C703	RC-KZ1308AFZZT	AD			4.7 μ F,6.3V
C704	RC-KZ1300AFZZN	AC			1 μ F,16V
C705	VCKYCZ0JB105KT	AB			1 μ F,6.3V
C706	VCKYCZ1EB102KT	AB			0.001 μ F,25V
C707	RC-KZ1300AFZZN	AC			1 μ F,16V
C708	RC-KZ1319AFZZN	AC			2.2 μ F,25V
C709	VCKYCY0JB225KT	AC			2.2 μ F,6.3V
C710	RC-KZ1319AFZZN	AC			2.2 μ F,25V
C711	VGCCZ1EH470JT	AB			47 pF (CH),25V
C712	VGCCZ1EH470JT	AB			47 pF (CH),25V
C713	RC-KZ1319AFZZN	AC			2.2 μ F,25V
C714	RC-KZ1308AFZZT	AD			4.7 μ F,6.3V
C718	VCKYCZ1AB104KT	AA			0.1 μ F,10V
C719	VCKYCZ1AB104KT	AA			0.1 μ F,10V
C721	VCKYCY1CB103KT	AB			0.01 μ F,16V
C722	VCKYCZ0JB105KT	AB			1 μ F,6.3V
C724	RC-KZ1319AFZZN	AC			2.2 μ F,25V
C725	VCKYCZ1AB104KT	AA			0.1 μ F,10V
C726	RC-KZ1327AFZZN	AB			2.2 μ F,16V
C728	VCKYCZ0JB105KT	AB			1 μ F,6.3V
C729	VCKYCZ0JB105KT	AB			1 μ F,6.3V
C732	VCKYCZ1AB104KT	AA			0.1 μ F,10V
C734	VCKYCZ1AB104KT	AA			0.1 μ F,10V
C736	VCKYCY1CB103KT	AB			0.01 μ F,16V
C737	VCKYCZ1AB104KT	AA			0.1 μ F,10V
C739	VCKYCZ1AB104KT	AA			0.1 μ F,10V
C740	RC-KZ1317AFZZN	AB			1 μ F,16V
C741	RC-KZ1314AFZZN	AC			1 μ F,25V
C742	VCKYCZ0JB105KT	AB			1 μ F,6.3V
C743	VCKYCZ0JB105KT	AB			1 μ F,6.3V
C744	RC-KZ1317AFZZN	AB			1 μ F,16V
C745	RC-KZ1317AFZZN	AB			1 μ F,16V
C746	VCKYCZ0JB105KT	AB			1 μ F,6.3V
C747	RC-KZ1317AFZZN	AB			1 μ F,16V
C748	VCKYCZ0JB105KT	AB			1 μ F,6.3V
C750	VCKYCZ0JB105KT	AB			1 μ F,6.3V
C751	VGCCZ1EH101JT	AB			100 pF (CH),25V
C752	VCKYCZ1AB104KT	AA			0.1 μ F,10V
C753	VCKYCY1CB104KT	AA			0.1 μ F,16V
C754	RC-KZ1317AFZZN	AB			1 μ F,16V
C755	VCKYCZ0JB105KT	AB			1 μ F,6.3V
C756	VCKYCZ0JB105KT	AB			1 μ F,6.3V
C757	VCKYCZ0JB105KT	AB			1 μ F,6.3V
C758	VGCCZ1HH100DT	AA			10 pF (CH),50V
C759	VGCCZ1HH100DT	AA			10 pF (CH),50V
C760	VGCCZ1HH100DT	AA			10 pF (CH),50V
C761	VGCCZ1HH100DT	AA			10 pF (CH),50V
C766	VCKYCY1CB103KT	AB			0.01 μ F,16V
C769	VCKYTV1CB105KT	AC			1 μ F,16V

NO.	PARTS CODE	PRICE RANK	NEW MARK	PART RANK	DESCRIPTION
[10] CAPACITORS					
C770	RC-KZ1308AFZZT	AD			4.7 μ F,6.3V
C771	RC-KZ1317AFZZN	AB			1 μ F,16V
C772	VCKYCY0JB105KT	AB			1 μ F,6.3V
C773	RC-KZ1317AFZZN	AB			1 μ F,16V
C774	VCKYCY0JB225KT	AC			2.2 μ F,6.3V
C775	RC-KZ1308AFZZT	AD			4.7 μ F,6.3V
C776	VCKYCY1AB105KT	AB			1 μ F,10V
C777	VCKYCY1AB105KT	AB			1 μ F,10V
C779	RC-KZ1308AFZZT	AD			4.7 μ F,6.3V
C780	RC-SZ1165AFZZL	AD			4.7 μ F,10V,Tantalum,Electrolytic
C781	RC-KZ3021AFZZN	AC			4.7 μ F,6.3V
C782	VCKYCY0JB225KT	AC			2.2 μ F,6.3V
C783	RC-KZ1308AFZZT	AD			4.7 μ F,6.3V
C784	RC-KZ1308AFZZT	AD			4.7 μ F,6.3V
C787	VCCCCZ1EH101JT	AB			100 pF (CH),25V
C790	VCKYCY1EB103KT	AA			0.01 μ F,25V
C791	VCKYCY1EB103KT	AA			0.01 μ F,25V
C792	VCKYCY1AB104KT	AA			0.1 μ F,10V
C794	VCKYCY1CB103KT	AB			0.01 μ F,16V
C795	VCKYCY0JB105KT	AB			1 μ F,6.3V
C801	VCKYCY0JB105KT	AB			1 μ F,6.3V
C802	VCKYCY0JB225KT	AC			2.2 μ F,6.3V
C803	VCKYCY1CB103KT	AB			0.01 μ F,16V
C806	VCKYCY0JB225KT	AC			2.2 μ F,6.3V
C807	VCKYCY1CB103KT	AB			0.01 μ F,16V
C810	VCKYCY0JB105KT	AB			1 μ F,6.3V
C811	VCCCCZ1EH220JT	AA			22 pF (CH),25V
C812	VCCCCZ1EH220JT	AA			22 pF (CH),25V
C830	VCKYCY0JB105KT	AB			1 μ F,6.3V
C831	RC-KZ3009AFZZN	AA			0.0022 μ F,50V
C831A	VCCCCZ1EH1R0CT	AA			1 pF (CH),25V
C832	VCCCCZ1EH271JT	AA			270 pF (CH),25V
C832A	VCCCCZ1EH4R0CT	AA			4 pF (CH),25V
C833	VCCCCZ1EH101JT	AB			100 pF (CH),25V
C834	VCKYCY1AB104KT	AA			0.1 μ F,10V
C835	VCKYCY1AB104KT	AA			0.1 μ F,10V
C836	VCCCCZ1EH101JT	AB			100 pF (CH),25V
C837	VCKYCY1AB104KT	AA			0.1 μ F,10V
C840	VCKYCY1EB331KT	AA			330 pF,25V
C841	RC-KZ3010AFZZN	AB			0.0033 μ F,50V
C842	VCKYCY1AB104KT	AA			0.1 μ F,10V
C843	RC-KZ3011AFZZN	AA			0.0018 μ F,50V
C844	RC-KZ3011AFZZN	AA			0.0018 μ F,50V
C845	VCKYCY1AB104KT	AA			0.1 μ F,10V
C850	RC-CZ3001AFZZN	AB			0.015 μ F,50V
C851	VCKYCY1EB182KT	AA			0.0018 μ F,25V
C852	VCCCCZ1EH0R5CT	AB			0.5 pF (CH),25V
C854	VCCCCZ1EH470JT	AB			47 pF (CH),25V
C855	VCCCCZ1EH470JT	AB			47 pF (CH),25V
C856	VCCCCZ1EH220JT	AA			22 pF (CH),25V
C857	VCCCCZ1EH220JT	AA			22 pF (CH),25V
C860	-----	--			This Parts is Supplied with Cabinet Parts 104
C861	VCCCCZ1EH101JT	AB			100 pF (CH),25V
C861A	VCCCCZ1EH820JT	AA			82 pF (CH),25V
C862	VCCCCZ1EH101JT	AB			100 pF (CH),25V
C863	VCCCCZ1EH470JT	AB			47 pF (CH),25V
C864	VCCCCZ1EH470JT	AB			47 pF (CH),25V
C865	-----	--			This Parts is Supplied with Cabinet Parts 104
C866	-----	--			This Parts is Supplied with Cabinet Parts 104
C867	VCCCCZ1EH470JT	AB			47 pF (CH),25V
C870	VCCCCZ1EH470JT	AB			47 pF (CH),25V
C871	VCCCCZ1EH470JT	AB			47 pF (CH),25V
C872	VCCCCZ1EH470JT	AB			47 pF (CH),25V
C873	VCKYCY1EB102KT	AB			0.001 μ F,25V
C874	VCCCCZ1EH470JT	AB			47 pF (CH),25V
C875	VCCCCZ1EH2R0CT	AB			2 pF (CH),25V
C876	VCCCCZ1EH1R0CT	AA			1 pF (CH),25V
C881	VCCCCZ1EH470JT	AB			47 pF (CH),25V
C885	VCCCCZ1EH1R0CT	AA			1 pF (CH),25V
[11] RESISTORS					
R101	VRS-CZ1JB000JT	AB			0 ohm,Jumper,0.5x1.0mm
R103	VRS-CZ1JB181JT	AA			180 ohms,1/16W
R104	VRS-CZ1JB561JT	AA			560 ohms,1/16W
R104A	VRS-CY1JB000JT	AA			0 ohm,Jumper,0.8x1.55mm,Green
R106	VRS-CZ1JB561JT	AA			560 ohms,1/16W
R107	VRS-CZ1JB561JT	AA			560 ohms,1/16W
R109	VRS-CZ1JB561JT	AA			560 ohms,1/16W
R110	VRS-CZ1JB561JT	AA			560 ohms,1/16W
R110A	VRS-CZ1JB000JT	AB			0 ohm,Jumper,0.5x1.0mm
R111	VRS-CZ1JB561JT	AA			560 ohms,1/16W
R112	VRS-CZ1JB000JT	AB			0 ohm,Jumper,0.5x1.0mm
R113	VRS-CZ1JB561JT	AA			560 ohms,1/16W
R115	VRS-CZ1JB101JT	AB			100 ohm,1/16W
R122	VRS-CZ1JB222JT	AB			2.2 kohms,1/16W

NO.	PARTS CODE	PRICE RANK	NEW MARK	PART RANK	DESCRIPTION
[11] RESISTORS					
R124	VRS-CZ1JB000JT	AB			0 ohm,Jumper,0.5x1.0mm
R125	VRS-CZ1JB222JT	AB			2.2 kohms,1/16W
R126	VRS-CZ1JB000JT	AB			0 ohm,Jumper,0.5x1.0mm
R127	VRS-CZ1JB474JT	AB			470 kohms,1/16W
R128	VRS-CZ1JB913JT	AA			91 kohms,1/16W
R129	VRS-CZ1JB222JT	AB			2.2 kohms,1/16W
R130	VRS-CZ1JB222JT	AB			2.2 kohms,1/16W
R131	VRS-CZ1JB271JT	AA			270 ohms,1/16W
R132	VRS-CZ1JB104FT	AA			100 kohm,1/16W
R133	RR-NZ1103AFZZN	AC			0.18 ohms,1/2W
R134	VRS-CZ1JB101JT	AB			100 ohm,1/16W
R135	VRS-CY1JB000JT	AA			0 ohm,Jumper,0.8x1.55mm,Green
R136	VRS-CY1JB000JT	AA			0 ohm,Jumper,0.8x1.55mm,Green
R137	VRS-CZ1JB000JT	AB			0 ohm,Jumper,0.5x1.0mm
R138	VRS-CZ1JB000JT	AB			0 ohm,Jumper,0.5x1.0mm
R139	VRS-CY1JB000JT	AA			0 ohm,Jumper,0.8x1.55mm,Green
R140	VRS-CZ1JB125JT	AA			1.2 Mohms,1/16W
R141	VRS-CZ1JB104JT	AA			100 kohm,1/16W
R142	VRS-CZ1JB273JT	AA			27 kohms,1/16W
R143	VRS-CZ1JB331JT	AB			330 ohms,1/16W
R144	VRS-CZ1JB000JT	AB			0 ohm,Jumper,0.5x1.0mm
R145	VRS-CZ1JB683JT	AA			68 kohms,1/16W
R146	VRS-CZ1JB183JT	AB			18 kohms,1/16W
R147	VRS-CZ1JB000JT	AB			0 ohm,Jumper,0.5x1.0mm
R148	VRS-CZ1JB103DT	AB			10 kohm,1/16W
R151	VRS-CZ1JB474JT	AB			470 kohms,1/16W
R152	VRS-CZ1JB000JT	AB			0 ohm,Jumper,0.5x1.0mm
R153	VRS-CZ1JB000JT	AB			0 ohm,Jumper,0.5x1.0mm
R155	VRS-CZ1JB474JT	AB			470 kohms,1/16W
R156	VRS-CY1JB000JT	AA			0 ohm,Jumper,0.8x1.55mm,Green
R157	VRS-CZ1JB102JT	AA			1 kohm,1/16W
R158	VRS-CZ1JB000JT	AB			0 ohm,Jumper,0.5x1.0mm
R159	VRS-CZ1JB332JT	AA			3.3 kohms,1/16W
R160	VRS-CZ1JB474JT	AB			470 kohms,1/16W
R161	VRS-CZ1JB000JT	AB			0 ohm,Jumper,0.5x1.0mm
R162	VRS-CZ1JB000JT	AB			0 ohm,Jumper,0.5x1.0mm
R163	VRS-CZ1JB000JT	AB			0 ohm,Jumper,0.5x1.0mm
R164	VRS-CZ1JB000JT	AB			0 ohm,Jumper,0.5x1.0mm
R165	VRS-CZ1JB103JT	AA			10 kohm,1/16W
R166	VRS-CZ1JB000JT	AB			0 ohm,Jumper,0.5x1.0mm
R167	VRS-CZ1JB206JT	AA			20 Mohms,1/16W
R168	VRS-CZ1JB000JT	AB			0 ohm,Jumper,0.5x1.0mm
R169	VRS-CZ1JB000JT	AB			0 ohm,Jumper,0.5x1.0mm
R170	VRS-CZ1JB000JT	AB			0 ohm,Jumper,0.5x1.0mm
R171	VRS-CZ1JB000JT	AB			0 ohm,Jumper,0.5x1.0mm
R172	VRS-CZ1JB000JT	AB			0 ohm,Jumper,0.5x1.0mm
R173	VRS-CZ1JB000JT	AB			0 ohm,Jumper,0.5x1.0mm
R174	VRS-CZ1JB000JT	AB			0 ohm,Jumper,0.5x1.0mm
R174A	VRS-CZ1JB106JT	AA			10 Mohm,1/16W
R175	VRS-CZ1JB000JT	AB			0 ohm,Jumper,0.5x1.0mm
R176	VRS-CZ1JB561JT	AA			560 ohms,1/16W
R177	VRS-CZ1JB000JT	AB			0 ohm,Jumper,0.5x1.0mm
R178	VRS-CZ1JB561JT	AA			560 ohms,1/16W
R179	VRS-CZ1JB270JT	AA			27 ohms,1/16W
R180	VRS-CZ1JB101JT	AB			100 ohm,1/16W
R181	VRS-CZ1JB101JT	AB			100 ohm,1/16W
R182	VRS-CZ1JB000JT	AB			0 ohm,Jumper,0.5x1.0mm
R183	VRS-CZ1JB474JT	AB			470 kohms,1/16W
R184	VRS-CZ1JB474JT	AB			470 kohms,1/16W
R185	VRS-CY1JB000JT	AA			0 ohm,Jumper,0.8x1.55mm,Green
R186	VRS-CY1JB000JT	AA			0 ohm,Jumper,0.8x1.55mm,Green
R187	VRS-CZ1JB000JT	AB			0 ohm,Jumper,0.5x1.0mm
R188	VRS-CZ1JB000JT	AB			0 ohm,Jumper,0.5x1.0mm
R189	VRS-CZ1JB474JT	AB			470 kohms,1/16W
R190	VRS-CZ1JB561JT	AA			560 ohms,1/16W
R191	VRS-CZ1JB474JT	AB			470 kohms,1/16W
R192	VRS-CZ1JB474JT	AB			470 kohms,1/16W
R195	VRS-CZ1JB000JT	AB			0 ohm,Jumper,0.5x1.0mm
R196	VRS-CZ1JB000JT	AB			0 ohm,Jumper,0.5x1.0mm
R197	VRS-CZ1JB000JT	AB			0 ohm,Jumper,0.5x1.0mm
R198	VRS-CZ1JB000JT	AB			0 ohm,Jumper,0.5x1.0mm
R199	VRS-CZ1JB000JT	AB			0 ohm,Jumper,0.5x1.0mm
R200	VRS-CZ1JB000JT	AB			0 ohm,Jumper,0.5x1.0mm
R201	VRS-CZ1JB000JT	AB			0 ohm,Jumper,0.5x1.0mm
R202	VRS-CZ1JB000JT	AB			0 ohm,Jumper,0.5x1.0mm
R203	VRS-CZ1JB000JT	AB			0 ohm,Jumper,0.5x1.0mm
R210	VRS-CZ1JB000JT	AB			0 ohm,Jumper,0.5x1.0mm
R211	VRS-CZ1JB561JT	AA			560 ohms,1/16W
R212	VRS-CZ1JB000JT	AB			0 ohm,Jumper,0.5x1.0mm
R218	VRS-CZ1JB000JT	AB			0 ohm,Jumper,0.5x1.0mm
R219	VRS-CZ1JB000JT	AB			0 ohm,Jumper,0.5x1.0mm
R220	VRS-CZ1JB000JT	AB			0 ohm,Jumper,0.5x1.0mm
R222	VRS-CZ1JB000JT	AB			0 ohm,Jumper,0.5x1.0mm
R224	VRS-CZ1JB000JT	AB			0 ohm,Jumper,0.5x1.0mm
R225	VRS-CZ1JB000JT	AB			0 ohm,Jumper,0.5x1.0mm

NO.	PARTS CODE	PRICE RANK	NEW MARK	PART RANK	DESCRIPTION
[11] RESISTORS					
R226	VRS-CZ1JB000JT	AB			0 ohm,Jumper,0.5x1.0mm
R227	VRS-CZ1JB000JT	AB			0 ohm,Jumper,0.5x1.0mm
R228	VRS-CZ1JB000JT	AB			0 ohm,Jumper,0.5x1.0mm
R231	VRS-CZ1JB000JT	AB			0 ohm,Jumper,0.5x1.0mm
R233	VRS-CZ1JB000JT	AB			0 ohm,Jumper,0.5x1.0mm
R234	VRS-CZ1JB000JT	AB			0 ohm,Jumper,0.5x1.0mm
R235	VRS-CZ1JB000JT	AB			0 ohm,Jumper,0.5x1.0mm
R237	VRS-CZ1JB000JT	AB			0 ohm,Jumper,0.5x1.0mm
R238	VRS-CZ1JB1R0JT	AA			1 ohm,1/16W
R239	VRS-CZ1JB000JT	AB			0 ohm,Jumper,0.5x1.0mm
R244	VRS-CZ1JB102JT	AA			1 kohm,1/16W
R245	VRS-CZ1JB102JT	AA			1 kohm,1/16W
R246	VRS-CZ1JB102JT	AA			1 kohm,1/16W
R248	VRS-CZ1JB000JT	AB			0 ohm,Jumper,0.5x1.0mm
R249	VRS-CZ1JB203JT	AA			20 kohms,1/16W
R254	VRS-CZ1JB752JT	AA			7.5 kohms,1/16W
R256	VRS-CZ1JB000JT	AB			0 ohm,Jumper,0.5x1.0mm
R258	VRS-CZ1JB000JT	AB			0 ohm,Jumper,0.5x1.0mm
R262	VRS-CZ1JB682JT	AA			6.8 kohms,1/16W
R263	VRS-CZ1JB682JT	AA			6.8 kohms,1/16W
R264	VRS-CZ1JB000JT	AB			0 ohm,Jumper,0.5x1.0mm
R266	VRS-CZ1JB474JT	AA			470 kohms,1/16W
R267	VRS-CZ1JB683DT	AA			68 kohms,1/16W
R268	VRS-CZ1JB124JT	AB			120 kohms,1/16W
R272	VRS-CZ1JB000JT	AB			0 ohm,Jumper,0.5x1.0mm
R277	VRS-CZ1JB000JT	AB			0 ohm,Jumper,0.5x1.0mm
R278	VRS-CZ1JB273JT	AA			27 kohms,1/16W
R279	VRS-CZ1JB474JT	AB			470 kohms,1/16W
R280	VRS-CZ1JB474JT	AB			470 kohms,1/16W
R281	VRS-CZ1JB000JT	AB			0 ohm,Jumper,0.5x1.0mm
R282	VRS-CZ1JB182DT	AA			1.8 kohms,1/16W
R283	VRS-CZ1JB222DT	AA			2.2 kohms,1/16W
R284	VRS-CZ1JB273JT	AA			27 kohms,1/16W
R285	VRS-CZ1JB474JT	AB			470 kohms,1/16W
R286	VRS-CZ1JB474JT	AB			470 kohms,1/16W
R291	VRS-CZ1JB474JT	AB			470 kohms,1/16W
R292	VRS-CZ1JB154JT	AA			150 kohms,1/16W
R293	VRS-CZ1JB154JT	AA			150 kohms,1/16W
R294	VRS-CZ1JB124JT	AB			120 kohms,1/16W
R295	VRS-CZ1JB124JT	AB			120 kohms,1/16W
R296	VRS-CZ1JB474JT	AB			470 kohms,1/16W
R501	VRS-CZ1JB000JT	AB			0 ohm,Jumper,0.5x1.0mm
R502	VRS-CZ1JB000JT	AB			0 ohm,Jumper,0.5x1.0mm
R503	VRS-CZ1JB000JT	AB			0 ohm,Jumper,0.5x1.0mm
R504	VRS-CZ1JB474JT	AB			470 kohms,1/16W
R505	VRS-CZ1JB152JT	AA			1.5 kohms,1/16W
R507	VRS-CZ1JB000JT	AB			0 ohm,Jumper,0.5x1.0mm
R508	VRS-CZ1JB272JT	AA			2.7 kohms,1/16W
R509	VRS-CZ1JB183JT	AB			18 kohms,1/16W
R511	VRS-CZ1JB473JT	AA			47 kohms,1/16W
R513	VRS-CZ1JB103JT	AA			10 kohm,1/16W
R514	VRS-CZ1JB474JT	AB			470 kohms,1/16W
R515	VRS-CZ1JB474JT	AB			470 kohms,1/16W
R516	VRS-CZ1JB474JT	AB			470 kohms,1/16W
R517	VRS-CZ1JB474JT	AB			470 kohms,1/16W
R518	VRS-CZ1JB104JT	AA			100 kohm,1/16W
R519	VRS-CZ1JB104JT	AA			100 kohm,1/16W
R520	VRS-CZ1JB473JT	AA			47 kohms,1/16W
R522	VRS-CZ1JB103JT	AA			10 kohm,1/16W
R523	VRS-CZ1JB474JT	AB			470 kohms,1/16W
R527	VRS-CZ1JB000JT	AB			0 ohm,Jumper,0.5x1.0mm
R528	VRS-CZ1JB000JT	AB			0 ohm,Jumper,0.5x1.0mm
R529	VRS-CZ1JB000JT	AB			0 ohm,Jumper,0.5x1.0mm
R530	VRS-CZ1JB101JT	AB			100 ohm,1/16W
R531	VRS-CZ1JB101JT	AB			100 ohm,1/16W
R532	VRS-CZ1JB101JT	AB			100 ohm,1/16W
R535	VRS-CY1JB000JT	AA			0 ohm,Jumper,0.8x1.55mm,Green
R536	VRS-CY1JB000JT	AA			0 ohm,Jumper,0.8x1.55mm,Green
R540	VRS-CY1JB000JT	AA			0 ohm,Jumper,0.8x1.55mm,Green
R542	VRS-CZ1JB000JT	AB			0 ohm,Jumper,0.5x1.0mm
R543	VRS-CZ1JB000JT	AB			0 ohm,Jumper,0.5x1.0mm
R544	VRS-CZ1JB000JT	AB			0 ohm,Jumper,0.5x1.0mm
R545	VRS-CZ1JB332JT	AA			3.3 kohms,1/16W
R547	VRS-CZ1JB104JT	AA			100 kohm,1/16W
R550	VRS-CZ1JB104JT	AA			100 kohm,1/16W
R552	VRS-CZ1JB104JT	AA			100 kohm,1/16W
R558	VRS-CZ1JB101JT	AB			100 ohm,1/16W
R559	VRS-CZ1JB474JT	AB			470 kohms,1/16W
R560	VRS-CZ1JB103JT	AA			10 kohm,1/16W
R561	VRS-CZ1JB124JT	AB			120 kohms,1/16W
R562	VRS-CZ1JB000JT	AB			0 ohm,Jumper,0.5x1.0mm
R563	VRS-CZ1JB000JT	AB			0 ohm,Jumper,0.5x1.0mm
R564	VRS-CZ1JB474JT	AB			470 kohms,1/16W
R565	VRS-CZ1JB474JT	AB			470 kohms,1/16W
R566	VRS-CZ1JB274JT	AA			270 kohms,1/16W

NO.	PARTS CODE	PRICE RANK	NEW MARK	PART RANK	DESCRIPTION
[11] RESISTORS					
R701	VRS-CZ1JB332JT	AA			3.3 kohms,1/16W
R703	VRS-CZ1JB103DT	AB			10 kohm,1/16W
R704	VRS-TV2ABR10JT	AA			0.1 ohm,1/10W
R704A	VRS-CZ1JB000JT	AB			0 ohm,Jumper,0.5x1.0mm
R705	VRS-CZ1JB000JT	AB			0 ohm,Jumper,0.5x1.0mm
R705A	VRS-CZ1JB000JT	AB			0 ohm,Jumper,0.5x1.0mm
R707	VRS-CZ1JB000JT	AB			0 ohm,Jumper,0.5x1.0mm
R708	VRS-CZ1JB124DT	AB			120 kohms,1/16W
R712	VRS-CZ1JB000JT	AB			0 ohm,Jumper,0.5x1.0mm
R713	VRS-CZ1JB1R0JT	AA			1 ohm,1/16W
R714	VRS-CZ1JB474JT	AB			470 kohms,1/16W
R716	VRS-CZ1JB000JT	AB			0 ohm,Jumper,0.5x1.0mm
R717	VRS-CZ1JB000JT	AB			0 ohm,Jumper,0.5x1.0mm
R718	VRS-CZ1JB3R3JT	AA			3.3 ohms,1/16W
R720	VRS-CZ1JB1R0JT	AA			1 ohm,1/16W
R723	VRS-CZ1JB000JT	AB			0 ohm,Jumper,0.5x1.0mm
R727	VRS-CZ1JB104JT	AA			100 kohm,1/16W
R728	VRS-CZ1JB000JT	AB			0 ohm,Jumper,0.5x1.0mm
R729	VRS-CZ1JB000JT	AB			0 ohm,Jumper,0.5x1.0mm
R730	VRS-CZ1JB000JT	AB			0 ohm,Jumper,0.5x1.0mm
R732	VRS-CZ1JB474JT	AB			470 kohms,1/16W
R737	VRS-CZ1JB000JT	AB			0 ohm,Jumper,0.5x1.0mm
R738	VRS-CZ1JB000JT	AB			0 ohm,Jumper,0.5x1.0mm
R740	VRS-CZ1JB563JT	AA			56 kohms,1/16W
R741	VRS-CZ1JB000JT	AB			0 ohm,Jumper,0.5x1.0mm
R743	VRS-CZ1JB000JT	AB			0 ohm,Jumper,0.5x1.0mm
R744	VRS-CZ1JB000JT	AB			0 ohm,Jumper,0.5x1.0mm
R745	VRS-CZ1JB000JT	AB			0 ohm,Jumper,0.5x1.0mm
R747	VRS-CZ1JB000JT	AB			0 ohm,Jumper,0.5x1.0mm
R748	VRS-CZ1JB000JT	AB			0 ohm,Jumper,0.5x1.0mm
R750	VRS-CZ1JB000JT	AB			0 ohm,Jumper,0.5x1.0mm
R756	VRS-CZ1JB000JT	AB			0 ohm,Jumper,0.5x1.0mm
R758	VRS-CZ1JB000JT	AB			0 ohm,Jumper,0.5x1.0mm
R760	VRS-CZ1JB474JT	AB			470 kohms,1/16W
R761	VRS-CZ1JB000JT	AB			0 ohm,Jumper,0.5x1.0mm
R802	VRS-CZ1JB472JT	AB			4.7 kohms,1/16W
R804	VRS-CZ1JB100JT	AA			10 ohm,1/16W
R805	VRS-CZ1JB682JT	AA			6.8 kohms,1/16W
R806	VRS-CZ1JB682JT	AA			6.8 kohms,1/16W
R807	VRS-CZ1JB330JT	AA			33 ohms,1/16W
R810	VRS-CZ1JB1R0JT	AA			1 ohm,1/16W
R811	VRS-CZ1JB1R0JT	AA			1 ohm,1/16W
R812	VRS-CZ1JB153JT	AA			15 kohms,1/16W
R835	VRS-CZ1JB000JT	AB			0 ohm,Jumper,0.5x1.0mm
R836	VRS-CZ1JB000JT	AB			0 ohm,Jumper,0.5x1.0mm
R837	VRS-CZ1JB000JT	AB			0 ohm,Jumper,0.5x1.0mm
R884	VRS-CZ1JB000JT	AB			0 ohm,Jumper,0.5x1.0mm
[12] OTHER CIRCUITRY PARTS					
AN501	RANTDA001AFZZL	AG			Aerial,Bluetooth
ANT801	QCNTAA003AFZZN	AE			Terminal,Aerial
BAT100	RDNTL0015AFZZ	AG			Battery,Back-up
CA1001	DKENDW108AFSN	BX			Camera Unit
CN102	QCNCWTL35AFZZL	AL			Socket,35Pin
CN103	QCNCWTL35AFZZL	AL			Socket,35Pin
CN104	QCNCWUB35AFZZL	AK			Socket,35Pin
CN501	QCNTAA002AFZZN	AG			Contact,Battery
CN502	QCNCW915KAFZZL	AM			Connector,External
CN503	QCNCW947FAFZZL	AF			Terminal,Bluetooth Aerial
CN701	QCNCMXO60AFZZN	AH			Plug,60Pin
CN703	QCNCWTV33AFZZL	AK			Socket,33Pin
CN704	QCNCWUB59AFZZL	AM			Socket,59Pin
CN705	QCNCW951DAFZZL	AD			Socket,4Pin
EP100	RPHODA002AFZZ	AK			Earpiece
FS501	QFS-L252EAFNZN	AC			Fuse,2.5A
FS701	QFS-L631EAFNZN	AC			Fuse,0.63A
FS702	QFS-L132BAFNZN	AC			Fuse,1.25A
J801	QCNCW927AAFZZR	AG			Connector,RF
JK101	QJAKMA001AFZZL	AF			Hands Free Connector
LCD001	RLCUB0049AFZZ	BD			External Display
LCD1000	RLCUB0048AFZZ	BS			Main Display
MiC100	RMiCC0213AFZZ	AL			Microphone
MO100	RMOTV0557AFZZ	AM			Vibrator
SP100	RSP-ZA001AFZZ	AM			Speaker

[13] CABINET PARTS

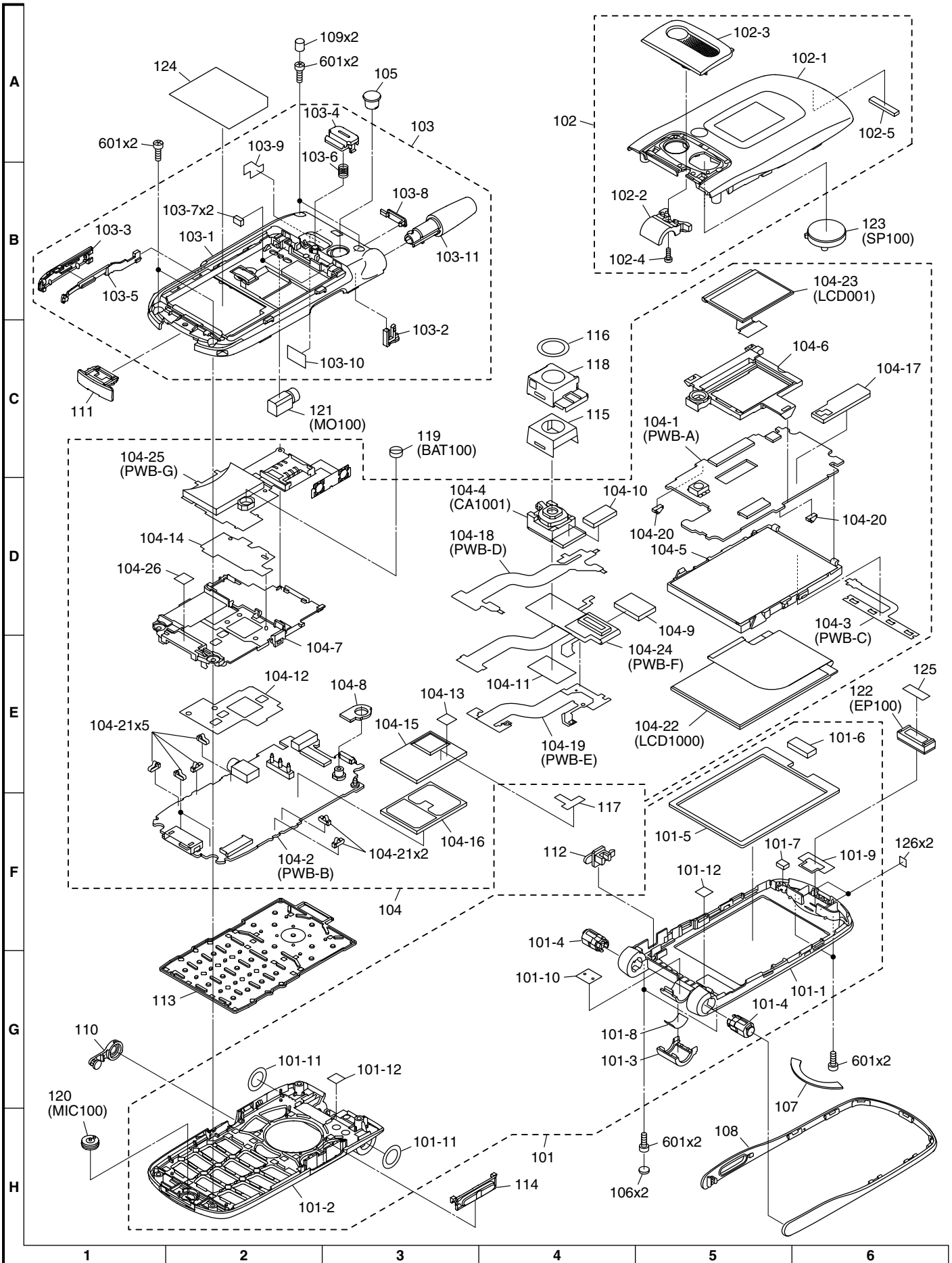

NO.	PARTS CODE	PRICE RANK	NEW MARK	PART RANK	DESCRIPTION
[13] CABINET PARTS					
101	DCABAW108AFSM	BE			Front Cabinet Assembly [K]
101	DCABAW108AFSP	BE			Front Cabinet Assembly [U]
101	DCABAW108AFS1	BD			Front Cabinet Assembly(Except for [K, U])
101-1	-----	--			Front Cabinet (Display) (Not Replacement Item)
101-2	GCABC7023AFSA	AQ			Front Cabinet (Key)
101-3	GCOVH1356AFSA	AG			Cover,Hinge (A)
101-4	MHNG-0210AFSB	AG			Hinge
101-5	PCUSSA019AFZZ	AE			Cushion,Display
101-6	PCUSS1033AFZZ	AB			Cushion,Driver
101-7	PMAGZ0072AFZZ	AD			Magnet
101-8	PSHEZA026AFZZ	AB			Sheet,Hinge Cover
101-9	PSHEZA049AFZZ	AD			Leak Mesh
101-10	PSHEZA166AFZZ	AC			Sheet,Hinge
101-11	PSHEZA175AFZZ	AB			Spacer,Hinge
101-12	TLABZ2783AFZZ	AA			Sensor,Moisture
102	DCABBW108AFSP	BA			Back Cabinet (Display) Assembly [U]
102	DCABBW108AFSG	BA			Back Cabinet (Display) Assembly [F]
102	DCABBW108AFSH	BA			Back Cabinet (Display) Assembly [C]
102	DCABBW108AFSM	BA			Back Cabinet (Display) Assembly [K]
102	DCABBW108AFS1	BA			Back Cabinet (Display) Assembly(Except for [F, C, K, U])
102-1	-----	--			Back Cabinet (Display) (Not Replacement Item)
102-2	GCOVH1357AFSA	AG			Cover,Hinge (B)
102-3	HPNLZ1209AFSA	AK			Panel,Camera
102-4	LX-BZA001AFZZ	AA			Screw (1.7x3.5)
102-5	PCUSSA023AFZZ	AA			Cushion,Board
103	DCABDW108AFS1	AZ			Back Cabinet (Key) Assembly
103-1	-----	--			Back Cabinet (Key) (Not Replacement Item)
103-2	GCOVH1360AFZZ	AB			Cover,Aerial
103-3	GFTAB1413AFSA	AH			Cover,SD Card
103-4	JKNBZ2370AFSA	AC			Knob,Battery Cover
103-5	LHLDZ1956AFZZ	AC			Belt,SD Card Cover
103-6	MSPRC1011AFZZ	AA			Spring,Battery Lock
103-7	PCUSSA022AFZZ	AA			Cushion,Battery
103-8	PFiLW0123AFZZ	AD			Filter,Infrared Port
103-9	PSHEZA170AFZZ	AC			Spacer,Infrared Port
103-10	PSHEZA183AFZZ	AB			Tape,Infrared Port
△ 103-11	QANTHA001AFSA	AM			Aerial
104	DKENDW108AFSA	CW			Board Unit [W]
104	DKENDW108AFSB	CW			Board Unit [B]
104	DKENDW108AFSC	CW			Board Unit [Z]
104	DKENDW108AFSD	CW			Board Unit [D]
104	DKENDW108AFSE	CW			Board Unit [Q]
104	DKENDW108AFSF	CW			Board Unit [L]
104	DKENDW108AFSG	CW			Board Unit [F]
104	DKENDW108AFSH	CW			Board Unit [C]
104	DKENDW108AFSM	CU			Board Unit [K]
104	DKENDW108AFSP	CU			Board Unit [U]
104	DKENDW108AFS1	CW			Board Unit [E]
104	DKENDW108AFS2	CW			Board Unit [G]
104	DKENDW108AFS3	CW			Board Unit [A]
104	DKENDW108AFS4	CW			Board Unit [EP]
104	DKENDW108AFS5	CW			Board Unit [R]
104	DKENDW108AFS6	CW			Board Unit [T]
104	DKENDW108AFS7	CW			Board Unit [PP]
104	DKENDW108AFS8	CW			Board Unit [S]
104	DKENDW108AFS9	CW			Board Unit [H]
△ 104-1	-----	--			Main (Not Replacement Item) (PWB-A)
△ 104-2	-----	--			Key (Not Replacement Item) (PWB-B)
104-3	CUiTKA003AFZZ	AM			Back Light FPC (PWB-C)
104-4	DKENDW108AFSN	BX			Camera Unit (CA1001)
104-5	LHLDZ1953AF01	AR			Main Display Holder Assembly
104-6	LHLDZ1954AF01	AN			External Display Holder Assembly
104-7	LHLDZ1958AFZZ	AH			Shield Case,BB
104-8	PCUSSA024AFZZ	AC			Cushion,Aerial
104-9	PCUSSA037AFZZ	AB			Cushion,Connector
104-10	PCUSSA086AFZZ	AB			Cushion,Camera Unit
104-11	PCUSSA121AFZZ	AB			Protect Sheet,Camera
104-12	PSHEZA036AFZZ	AC			Insulator,BB
104-13	PSHEZA178AFZZ	AB			Sheet,Side Keys
104-14	PSLDC3350AFZZ	AC			Shield Plate,BB
△ 104-15	PSLDMA015AFZZ	AE			Case RF,Shield (Cover)
△ 104-16	PSLDMA016AFZZL	AE			Case RF,Shield (Frame)
104-17	PSLDMA017AFZZL	AD			Case,Shield
104-18	QPWBH0749AFZZ	AK			Camera Ground FPC (PWB-D)
104-19	QPWBHA049AFZZ	AH			Ground FPC (PWB-E)
104-20	QTANZ9193AFZZL	AB			Contact,Spring (A)
104-21	QTANZA001AFZZL	AB			Contact,Spring (B)
104-22	RLCUB0048AFZZ	BS			Main Display (LCD1000)
104-23	RLCUB0049AFZZ	BD			External Display (LCD001)
104-24	RUNTKA014AFZZ	BC			Camera Relay FPC (PWB-F)
104-25	RUNTKA016AFZZ	AX			SD/SIM FPC (PWB-G)
104-26	TLABZ2595AFZZ	AA			Sensor,Moisture
105	GCOVA2546AFSB	AC			Cap,Aerial
106	GCOVA2552AFSJ	AC			Screw Cover,Display (Small)

NO.	PARTS CODE	PRICE RANK	NEW MARK	PART RANK	DESCRIPTION
[13] CABINET PARTS					
107	GCOVA2569AFSA	AD			Screw Cover,Display (Large)
108	GCOVAA039AFZZ	AR			Frame,Side
109	GCOVD1119AFSU	AB			Screw Cover,Key
110	GCOVH1358AFSA	AC			Cover,Jack (Hands Free)
111	GCOVH1359AFSA	AD			Cover,External Connector
112	JKNBPA002AFSA	AG			Lever,Close-up
113	JKNBZ2371AFSA	AW			Button,10 Key
114	JKNBZ2372AFSA	AG			Keys,Side
115	LHLDZ1952AFSA	AC			Holder,Camera
116	PCUSSA029AFZZ	AC			Cushion,Camera
117	PSHEMA001AFZZ	AD			Sheet,Aerial
118	PSLDCA002AFZZ	AD			Shield Case,Camera
119	RDNTL0015AFZZ	AG			Battery,Back-up (BAT100)
120	RMiCC0213AFZZ	AL			Microphone (MIC100)
121	RMOTV0557AFZZ	AM			Vibrator (MO100)
122	RPHODA002AFZZ	AK			Earpiece (EP100)
123	RSP-ZA001AFZZ	AM			Speaker (SP100)
124	TSPC-A088AFZZ	DD			Label,Specifications (Except for [A, Z, F])
124	TSPC-A089AFZZ	DD			Label,Specifications [A, Z]
124	TSPC-A090AFZZ	DD			Label,Specifications [F]
125	PSHEZA204AFZZ	AB			Sheet,Earpiece (A)
126	-----	--			Sheet,Earpiece (B) (Not Replacement Item)
601	LX-EZ0195AFZZ	AB			Screw (1.7x5)

[14] ACCESSORIES/PACKING PARTS

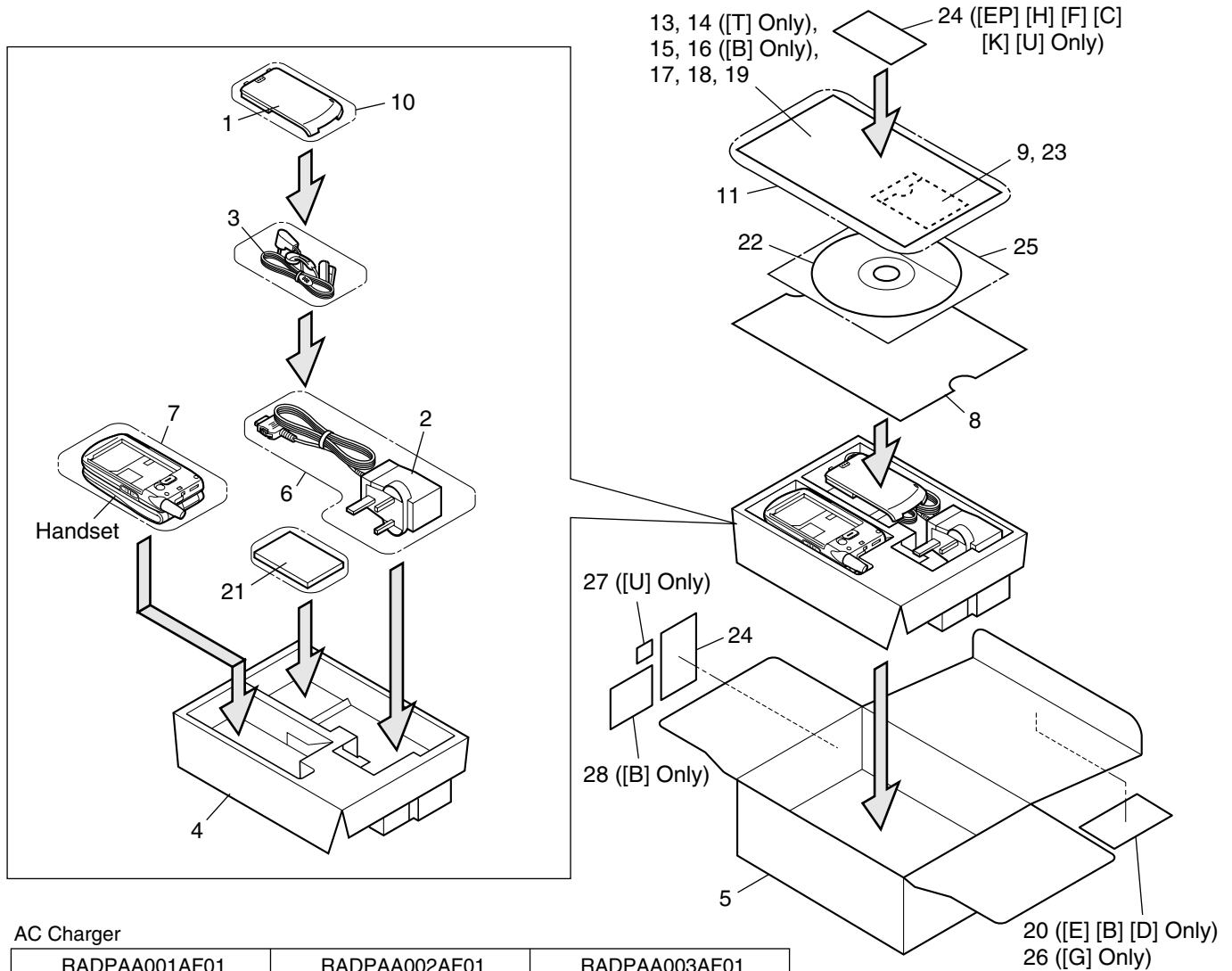

AC Charger

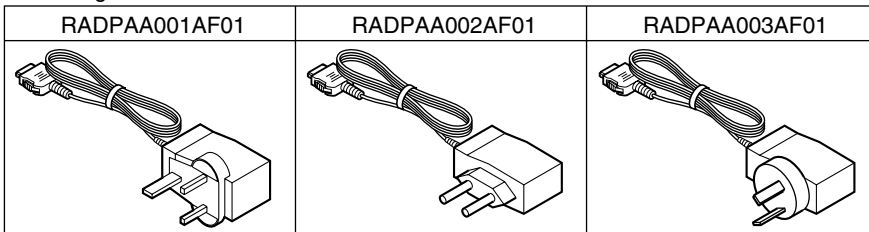

NO.	PARTS CODE	PRICE RANK	NEW MARK	PART RANK	DESCRIPTION
[14] ACCESSORIES/PACKING PARTS					
1	GFTAB1412AFSA	AG			Cover,Battery
2	RADPAA001AF01	**			AC Charger [E, EP, R, L] (XN-1QC30)
2	RADPAA002AF01	**			AC Charger [G, T, PP, S, H, W, B, D, Q, F, C, K, U] (XN-1QC31)
2	RADPAA003AF01	**			AC Charger [A, Z] (XN-1QC32)
3	RUNTZ0893AFZZ	AS			Hands Free Kit
4	SPAKA2823AFZZ	AG			Packing Add.
5	SPAKCA031AFZZ	AM			Packing Case [E, G, B, D, PP, R, T, S, W, L, Q]
5	SPAKCA067AFZZ	AK			Packing Case [EP, H, F, C, K]
5	SPAKCA086AFZZ	AM			Packing Case [A, Z]
5	SPAKCA162AFZZ	AK			Packing Case [U]
6	SPAKP1252AFZZ	AC			Polyethylene Bag,AC Charger
7	SPAKP1284AFZZ	AC			Polyethylene Bag,Unit
8	SPAKXA019AFZZ	AD			Spacer
9	SSAKAA003AFZZ	AC			SD Soft Case
10	SSAKH0329AFZZ	AA			Polyethylene Bag,Battery Cover
11	SSAKH0337AFZZ	AB			Polyethylene Bag,User Guide (Except for [U])
11	SPAKPA013AFZZ	AC			Polyethylene Bag,User Guide [U]
13	TCADHA015AFZZ	AF			Quick Start Guide [E, EP, A, Z, Q, R, L]
13	TCADHA016AFZZ	AF			Quick Start Guide [G]
13	TCADHA017AFZZ	AP			Quick Start Guide [S]

△
△
△

NO.	PARTS CODE	PRICE RANK	NEW MARK	PART RANK	DESCRIPTION
[14] ACCESSORIES/PACKING PARTS					
13	TCADHA018AFZZ	AG			Quick Start Guide [T]
13	TCADHA019AFZZ	AP			Quick Start Guide [PP]
13	TCADHA020AFZZ	AP			Quick Start Guide [H]
13	TCADHA021AFZZ	AP			Quick Start Guide [B]
13	TCADHA022AFZZ	AL			Quick Start Guide [W]
13	TCADHA023AFZZ	AH			Quick Start Guide [D]
14	TCADZ0263AFZZ	AC			Card,Free Service ([T] Only)
15	TCADZA006AFZZ	AB			Post Card Service Guide [E, EP, H, R]
15	TCADZA013AFZZ	AB			Post Card Service Guide [G]
15	TCADZA014AFZZ	AC			Post Card Service Guide [T]
15	TCADZA016AFZZ	AE			Post Card Service Guide [S]
15	TCADZA017AFZZ	AE			Post Card Service Guide [PP]
15	TCADZA018AFZZ	AC			Post Card Service Guide [D]
15	TCADZA019AFZZ	AD			Post Card Service Guide [W]
15	TCADZA034AFZZ	AC			Post Card Service Guide [C]
15	TCADZA042AFZZ	AC			Post Card Service Guide [F]
15	TCADZA051AFZZ	AC			Post Card Service Guide [K]
15	TCADZA053AFZZ	AB			Post Card Service Guide [U (English)]
15	TCADZA055AFZZ	AB			Post Card Service Guide [U (Datch)]
15	TCADZA057AFZZ	AB			Post Card Service Guide [U (French)]
16	TCADZA020AFZZ	AD			DOC Copy ([B]Only)
17	TCADZA022AFZZ	AB			MML Service Guide [E, EP, R]
17	TCADZA023AFZZ	AD			MML Service Guide [S]
17	TCADZA024AFZZ	AD			MML Service Guide [T]
17	TCADZA025AFZZ	AD			MML Service Guide [PP]
17	TCADZA026AFZZ	AD			MML Service Guide [H]
17	TCADZA028AFZZ	AC			MML Service Guide [D]
17	TCADZA038AFZZ	AB			MML Service Guide [C]
17	TCADZA052AFZZ				MML Service Guide [K]
17	TCADZA054AFZZ	AC			MML Service Guide [U (English)]
17	TCADZA056AFZZ				MML Service Guide [U (Datch)]
17	TCADZA058AFZZ				MML Service Guide [U (French)]
18	TGANEA001AFZZ	AE			Guarantee [Q, L]
18	TGANEA009AFZZ	AB			Guarantee [E, EP]
18	TGANEA010AFZZ	AE			Guarantee [R]
18	TGANEA011AFZZ	AE			Guarantee [A, Z]
18	TGANGA002AFZZ	AC			Guarantee [K]
18	TGANiA002AFZZ	AC			Guarantee [T]
18	TGANZA012AFZZ	AE			Guarantee [PP]
18	TGANZA013AFZZ	AC			Guarantee [D]
18	TGANZA014AFZZ	AD			Guarantee [W]
18	TGANZA015AFZZ	AE			Guarantee [B]
18	TGANZA016AFZZ	AD			Guarantee [C]
18	TGANZA017AFZZ	AE			Guarantee [H]
18	TGANZA018AFZZ	AE			Guarantee [S]
18	TGANZA026AFZZ	AC			Guarantee [U]
19	TiNSEA004AFZZ	AK			User Guide [E, EP, R, Q, L]
19	TiNSEA018AFZZ	AP			User Guide [A, Z]
19	TiNSEA028AFZZ	AK			User Guide [U (English)]
19	TiNSFA012AFZZ	AL			User Guide [F]
19	TiNSFA014AFZZ	AK			User Guide [U (French)]
19	TiNSGA002AFZZ	AK			User Guide [G]
19	TiNSGA019AFZZ	AL			User Guide [C]
19	TiNSGA020AFZZ	AL			User Guide [K]
19	TiNSHA008AFZZ	AP			User Guide [H]
19	TiNSHA013AFZZ	AK			User Guide [U (Datch)]
19	TiNSiA007AFZZ	AL			User Guide [T]
19	TiNSPA010AFZZ	AP			User Guide [PP]
19	TiNSSA009AFZZ	AP			User Guide [S]
19	TiNSWA011AFZZ	AP			User Guide [W]
19	TiNSZA005AFZZ	AN			User Guide [D]
19	TiNSZA006AFZZ	AN			User Guide [B]
20	TLABZ2793AFZZ	AA			Sheet,Security ([E, B, D] Only)
△	21	UBATiA004AFZZ	**		Rechargeable Li-ion Battery (XN-1BT30)
22	UDSKAA014AF01	AK			CD-ROM
23	U iMC-A002AFZZ	BC			SD Card (Except for [C, F, K, U])
23	U iMC-A003AFZZ	BC			SD Card ([C, F, K, U] Only)
24	-----	--			Label,Case
25	SSAKA0233AFZZ	AD			Polyethylene Bag,CD-ROM
26	TLABZA044AFZZ	AC			Sheet,Transparent ([G] Only)
27	TLABZA061AFZZ				Label,Battery ([U] Only)
28	TLABZA059AFZZ	AB			Label,Hungary ([B] Only)
[15] P.W.B. ASSEMBLY					
△	PWB-A	-----	--		Main (Not Replacement Item)
△	PWB-B	-----	--		Key (Not Replacement Item)
	PWB-C	CU iTKA003AFZZ	AM		Back Light FPC
	PWB-D	QPWBH0749AFZZ	AK		Camera Ground FPC
	PWB-E	QPWBHA049AFZZ	AH		Ground FPC
	PWB-F	RUNTKA014AFZZ	BC		Camera Relay FPC
	PWB-G	RUNTKA016AFZZ	AX		SD/Siμ FPC

– MEMO –

SHARP

COPYRIGHT © 2004 BY SHARP CORPORATION

ALL RIGHTS RESERVED.

No part of this publication may be reproduced, stored in a retrieval system, or transmitted in any form or by any means, electronic, mechanical, photocopying, recording, or otherwise, without prior written permission of the publisher.

SHARP CORPORATION
Communication Systems Group
Quality & Reliability Control Center
Higashihiroshima, Hiroshima 739-0192, Japan

B0406-PDF·KS·KJ·J