

SERVICE Manual

DUAL BAND MOBILE CELLULAR PHONE



CONTENTS

1. Exploded Views and Parts List
2. PCB Diagrams
3. Electrical Parts List
4. Block Diagrams
5. Flow Chart of Troubleshooting and Circuit Diagram

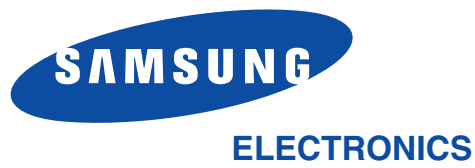

Samsung Electronics Co.,Ltd.
Printed in Korea
11/2002 Rev 1.0
GH68-03108A

1. Exploded Views and Parts List

- 1-1 Main
- 1-2 Main Parts List
- 1-3 Travel Adapter
- 1-4 Travel Adapter Parts List
- 1-5 Ciger Light Adapter
- 1-6 Ciger Light Adapter Parts List
- 1-7 Test Jig
- 1-8 Wearable EAR Microphone
- 1-9 Data Kit
- 1-10 Battery Charger

2. PCB Diagrams

- 2-1 Main Top
- 2-2 Main Bottom

3. Electrical Parts List

- 3-1 Main Parts List Top
- 3-2 Main Parts List Bottom

4. Block Diagrams

- 4-1 Main Base Band
- 4-2 Main RF
 - 4-2-1 RF Transmit Part
 - 4-2-2 RF Receive Part

5. Flow chart of Troubleshooting and Circuit Diagram

- 5-1 Power ON
- 5-2 Initial
- 5-3 Charging Part
- 5-4 Sim Part
- 5-5 Microphone Part
- 5-6 Speaker Part
- 5-7 Key Data Input
- 5-8 Receiver Part
- 5-9 Ring Indicator
- 5-10 Back Light (for Main & Sub LCD)
- 5-11 Back Light (for Key)
- 5-12 GSM Receiver
- 5-13 GSM Transmit
- 5-14 DCS Receiver
- 5-15 DCS Transmit

1. Exploded Views and Parts List

1-1 Main

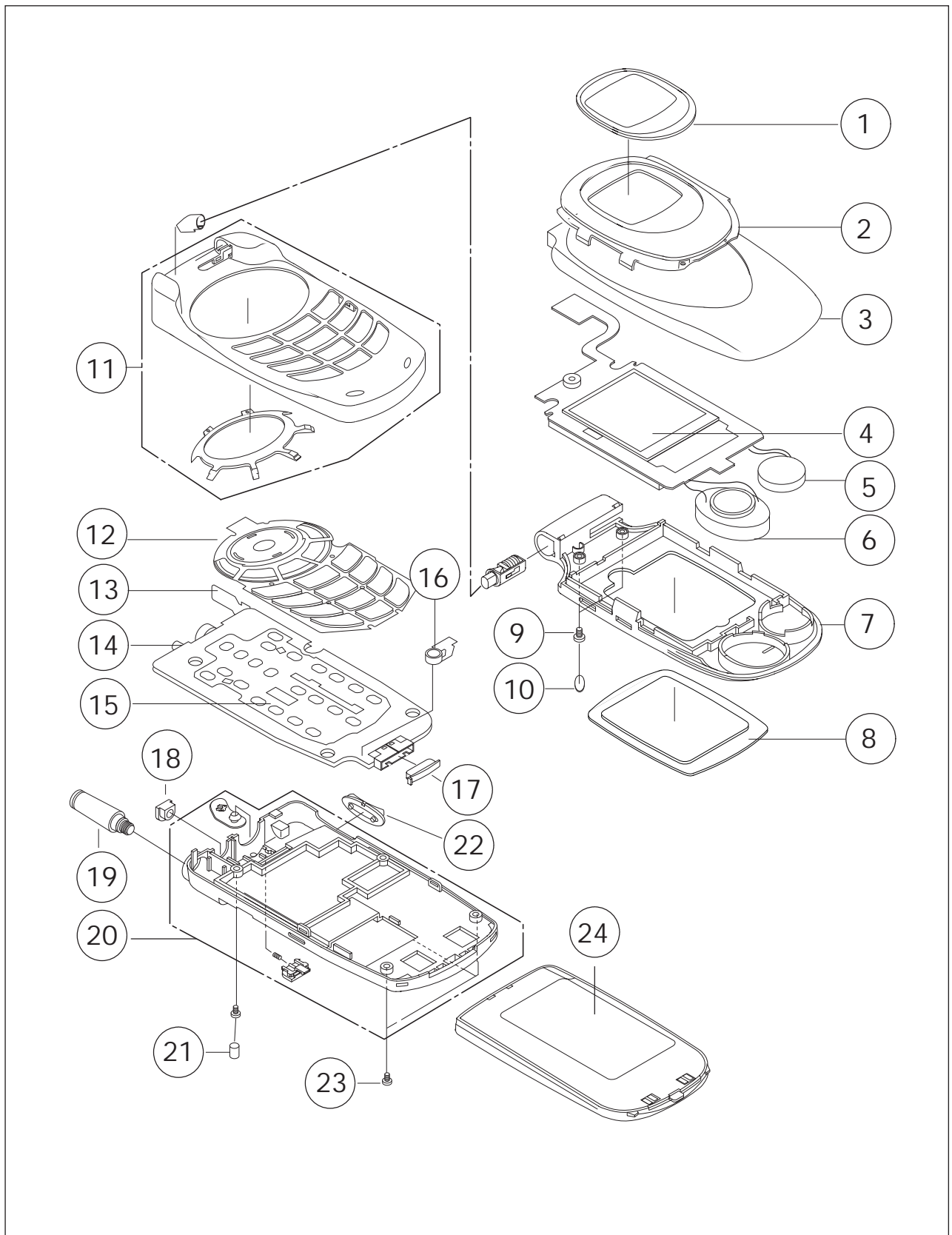

1-2 Main Parts List

Location No.	Description	SEC CODE	Remark
1	DUAL WINDOW LCD	GH72-04824A	
2	FOLDER DUMMY	GH75-02119A	
3	FOLDER UPPER	GH75-02117A	
4	LCD	GH07-00181A	
5	MOTOR	3101-001328	
6	SPEAKER	3001-001319	
7	FOLDER LOWER	GH75-02118A	
8	WINDOW LCD	GH72-04823A	
9	SCREW	6001-001285	
10	SCREW SHEET	GH74-02895A	
11	FRONT COVER	GH75-02116A	
12	KEYPAD	GH75-02136A	
13	VOLKEY F-PCB	GH59-00474A	
14	MAIN PBA	GH92-01334A	
15	DOME SHEET	GH59-00475A	
16	MIC	GH59-00476A	
17	CONNECTOR COVER	GH73-01282A	
18	RF COVER	GH73-01281A	
19	ANTENNA	GH42-00201A	
20	REAR COVER	GH75-02121A	
21	SCREW CAP	GH73-01283A	
22	VOLUME KEY	GH75-02120A	
23	SCREW	6001-000464	
24	BATTERY	GH43-00667A	

SGH-A800 COLOR & CODE

ITEM	COLOR	SILVER	Dark Silver	Dark Blue	Royal Blue
FOLDER UPPER		GH75-02117A	GH75-02117B	GH75-02117C	GH75-02117D
FOLDER LOWER		GH75-02118A	GH75-02118B	GH75-02118C	GH75-02118D
FRONT COVER		GH75-02116A	GH75-02116B	GH75-02116C	GH75-02116D
REAR COVER		GH75-02121A	GH75-02121B	GH75-02121C	GH75-02121D
FOLDER DUMMY		GH75-02119A	GH75-02119B	GH75-02119C	GH75-02119D

ITEM	COLOR	SILVER	Dark Silver	Dark Blue	Royal Blue
FOLDER UPPER		GH72-04819A	GH72-04819B	GH72-04819C	GH72-04819D
FOLDER LOWER		GH72-04822A	GH72-04822B	GH72-04822C	GH72-04822D
FRONT COVER		GH72-04825A	GH72-04825B	GH72-04825C	GH72-04825D
REAR COVER		GH72-04827A	GH72-04827B	GH72-04827C	GH72-04827D
FOLDER DUMMY		GH72-04821A	GH72-04821B	GH72-04821C	GH72-04821D

ITEM	COLOR	SILVER	Dark Silver	Dark Blue	Royal Blue
MAIN LOCKER		GH72-04828A	GH72-04828B	GH72-04828C	GH72-04828D
EARPHONE COVER		GH72-05132A	GH72-05132B	GH72-05132C	GH72-05132D
DAMPER(L)		GH73-01276A	GH73-01276B	GH73-01276C	GH73-01276D
MIC HOLDER		GH73-01277A	GH73-01277B	GH73-01277C	GH73-01277D
SCREW CAP SHEET		GH74-02895A	GH74-02895B	GH74-02895C	GH74-02895D

ITEM	COLOR	SILVER	Dark Silver	Dark Blue	Royal Blue
SCREW CAP		GH73-01283A	GH73-01283B	GH73-01283C	GH73-01283D
MOBILE CAP		GH73-01281A	GH73-01281B	GH73-01281C	GH73-01281D
I/F CONN COVER		GH73-01282A	GH73-01282B	GH73-01282C	GH73-01282D
SHEET REAR		GH74-03415A	GH74-03415B	GH74-03415C	GH74-03415D

1-3 Travel Adapter

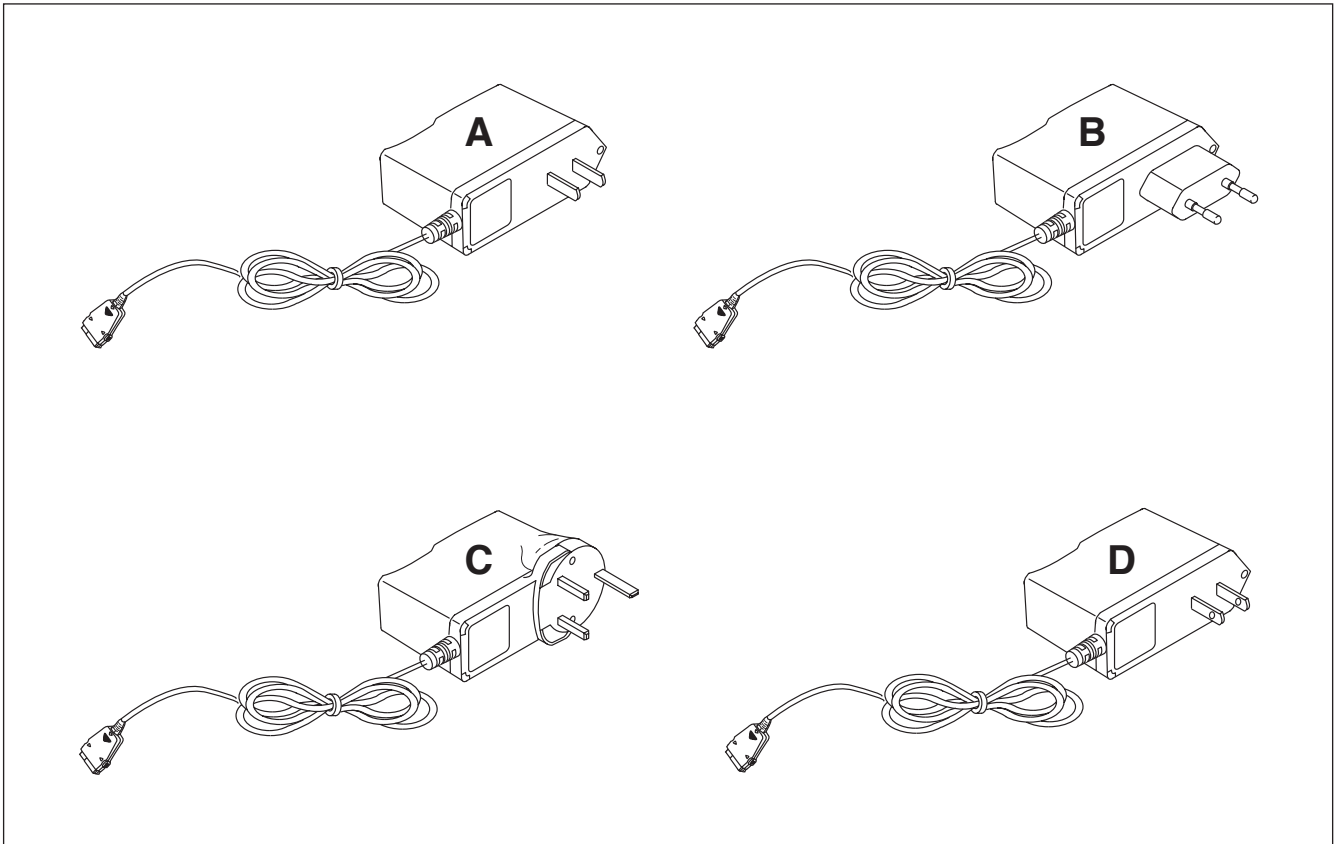

1-4 Travel Adapter Parts List

TYPE	SEC CODE	REMARK
A	GH44-00171A	CHINA
B	GH44-00184A	EUROPE
C	GH44-00171C	UNITED KINGDOM
D	Gh44-00171E	TAIWAN

1-5 Ciger Light Adapter

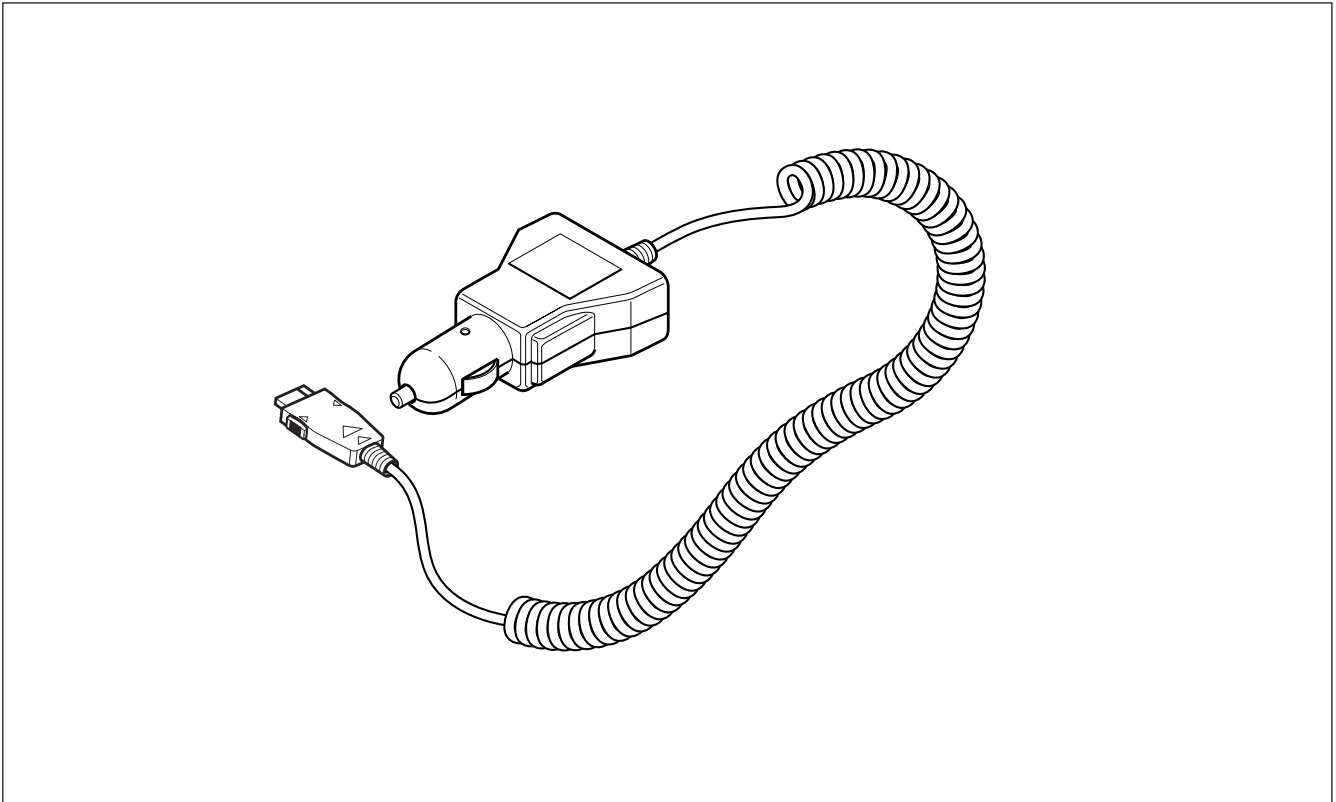

1-6 Ciger Light Adapter Parts List

DESCRIPTION	SEC CODE	REMARK
Ciger Light Adapter Code	GH44-00170A	BLACK

1-7 Test Jig

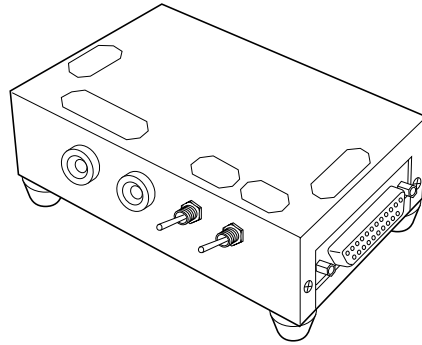

TEST JIG

GH80-10508A

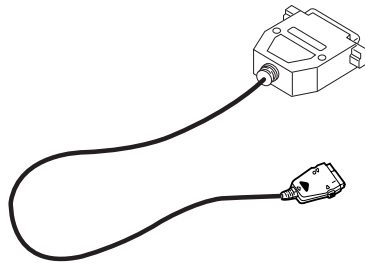

TEST JIG CABLE

GH39-00079A

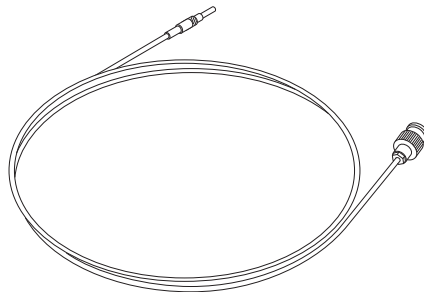

RF JIG CABLE

GH39-00174A

1-7 Test Jig

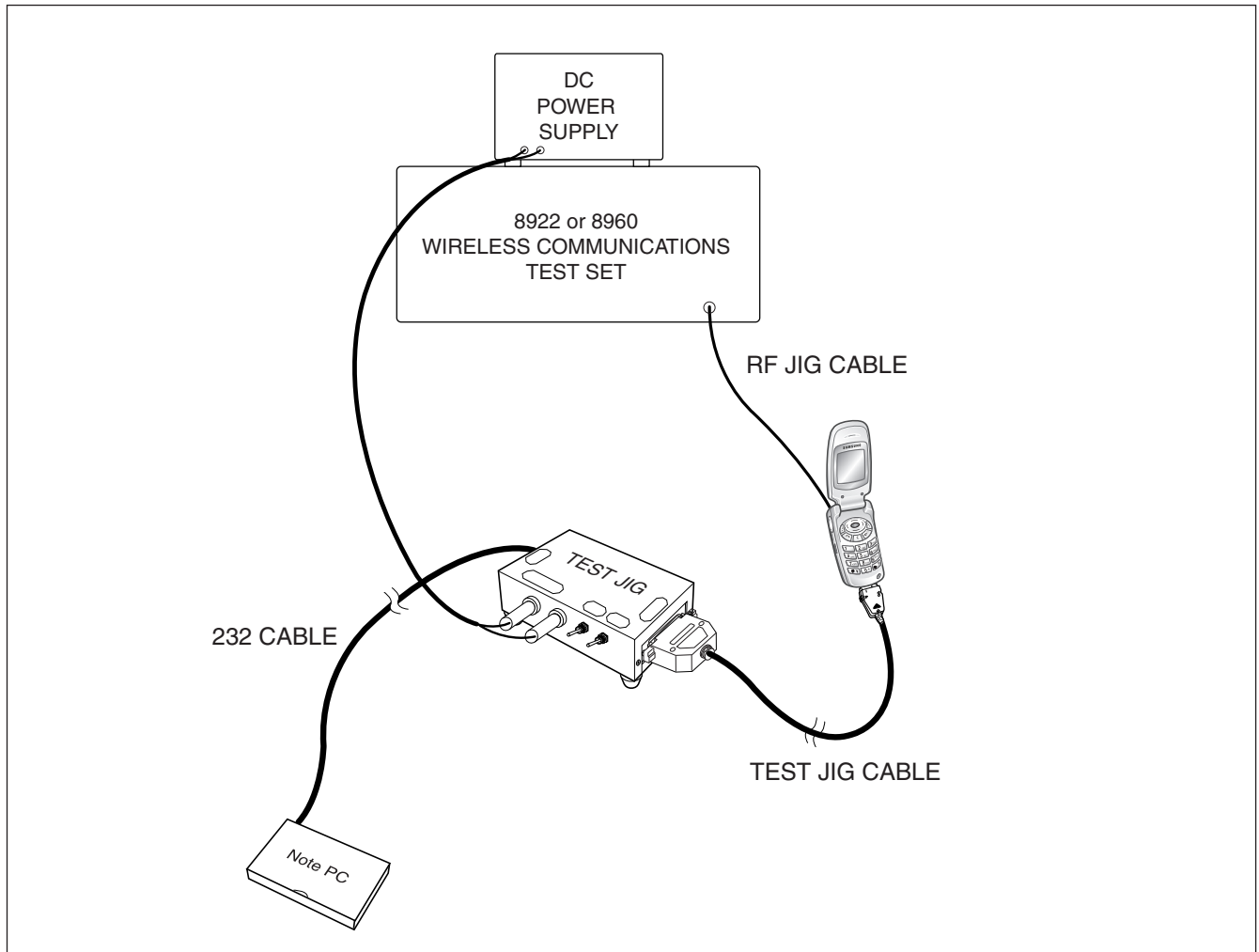

1-8 Wearable EAR Microphone

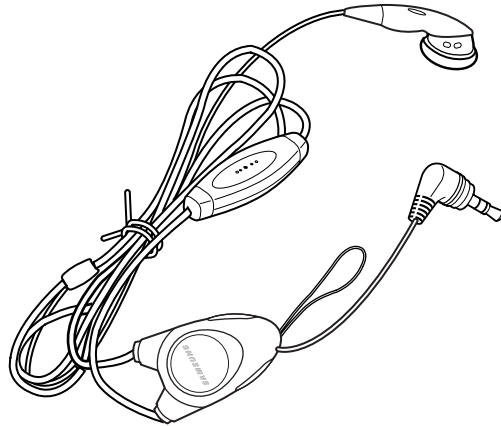

Wearable EAR Microphone

GH59-00322A

1-9 Data Kit

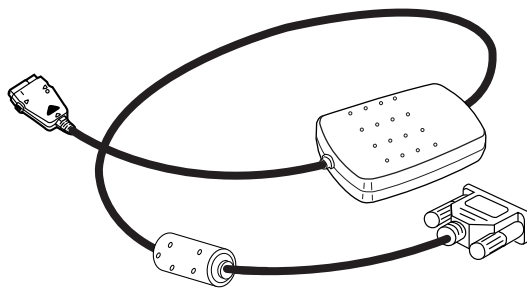

DATA KIT

GH39-00078A

1-10 Battery Charger

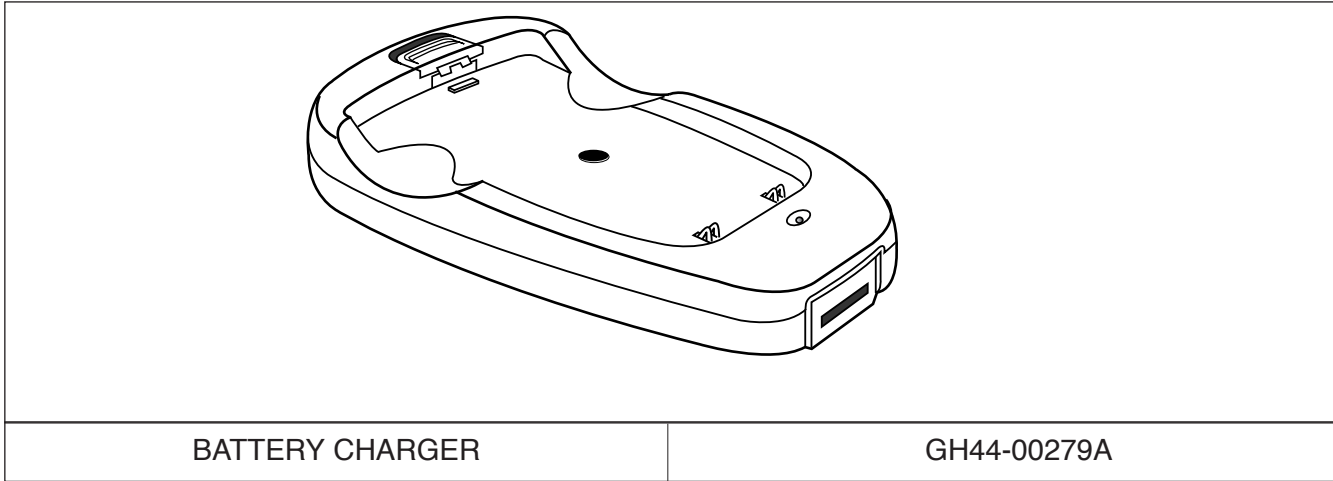

3. Electrical Parts List

3-1 Main Parts List Top

NO	Reference	SEC CODE	Part	Description	Vendor Part No.
1	C234	2203-000679	"C-CERAMIC,CHIP"	"0.027nF,5%,50V,NP0,TP,1005"	GRP1555C1H270JZ01E
2	R414	2007-000162	R-CHIP	"100Kohm,5%,1/16W,DA,TP,1005"	RC1005J104CS
3	C312	2404-001086	"C-TA,CHIP"	"4.7uF,20%,6.3V,GP,TP,2012,-"	TESVSPOJ475M8RTJ
4	C313	2203-005061	"C-CERAMIC,CHIP"	"100nF,+80-20%,16V,Y5V,TP,1005"	MCH153F104ZK
5	C311	2203-000233	"C-CERAMIC,CHIP"	"0.1nF,5%,50V,NP0,TP,1005"	CM05CG101J50AT
6	C437	2203-005444	"C-CERAMIC,CHIP"	"0.003nF,0.1pF,50V,NP0,TP,1005"	GRP1555C1H3R0BZ01E
7	R309	2007-000161	R-CHIP	"82Kohm,5%,1/16W,DA,TP,1005"	ERJ2GEJ823X
8	R307	2007-007771	R-CHIP	"0OHM,5%,1/16W,DA,TP,1005"	ERJ2GEJ0R0E
9	R310	2007-007090	R-CHIP	"11KOHM,5%,1/16W,DA,TP,1005"	ERJ2GEJ113X
10	C315	2203-005061	"C-CERAMIC,CHIP"	"100nF,+80-20%,16V,Y5V,TP,1005"	MCH153F104ZK
11	R308	2007-000153	R-CHIP	"22Kohm,5%,1/16W,DA,TP,1005"	ERJ2GEJ223X
12	C310	2203-005483	"C-CERAMIC,CHIP"	"68nF,10%,10V,X5R,TP,1005,-"	GRP155R61A683KA01E
13	C309	2203-005061	"C-CERAMIC,CHIP"	"100nF,+80-20%,16V,Y5V,TP,1005"	MCH153F104ZK
14	C307	2203-005061	"C-CERAMIC,CHIP"	"100nF,+80-20%,16V,Y5V,TP,1005"	MCH153F104ZK
15	Q200	0501-002202	TR-SMALL SIGNAL	"MMBT2222AWT1,NPN,150mW,SOT-323"	MMBT2222AWT1
16	Q702	0504-001058	TR-DIGITAL	"RN4985,NPN/PNP,200mW,2.2Kohm/ 47Kohm,UMD6,TP"	RN4985-TE85L
17	U202	0504-001060	TR-DIGITAL	"BCR08PN,NPN/PNP,250mW,2.2Kohm/ 47Kohm,SOT-363,TP"	BCR08PN
18	LAMP200	0601-001547	LED	"CHIP,BLUE,1.1X0.8MM,468NM"	SLS-NNBL102TS
19	LAMP201	0601-001547	LED	"CHIP,BLUE,1.1X0.8MM,468NM"	SLS-NNBL102TS
20	LAMP202	0601-001547	LED	"CHIP,BLUE,1.1X0.8MM,468NM"	SLS-NNBL102TS
21	LAMP203	0601-001547	LED	"CHIP,BLUE,1.1X0.8MM,468NM"	SLS-NNBL102TS
22	LAMP204	0601-001547	LED	"CHIP,BLUE,1.1X0.8MM,468NM"	SLS-NNBL102TS
23	LAMP205	0601-001547	LED	"CHIP,BLUE,1.1X0.8MM,468NM"	SLS-NNBL102TS
24	LAMP206	0601-001547	LED	"CHIP,BLUE,1.1X0.8MM,468NM"	SLS-NNBL102TS
25	LAMP207	0601-001547	LED	"CHIP,BLUE,1.1X0.8MM,468NM"	SLS-NNBL102TS
26	U200	0801-002540	IC-CMOS LOGIC	"7SZ19,DECODER,SOP,6P,49MIL,SINGLE,TP, PLASTIC,-,-,0.55V,-40to+85C,-,4.125V,1uA,-"	NC7SZ19P6X
27	Q201	1003-001440	IC-POWER DRIVER	"MDC3105LT1,SOT-23,3P,49MIL,-,500MA,TP," PLASTIC,6V,-40TO+85C,225MA,-,-	MDC3105LT1
28	U203	1009-001010	IC-HALL EFFECT S/W	"A3212ELH-SAMSUNG,SC-59A,3P,82MIL,TP, BICMOS,PLASTIC,3.5V,2MA,-40TO+85C,-,-,340K"	A3212ELHLT-SAMSUNG
29	U103	1203-002076	IC-VOLTAGE REGULATOR	"2985,SOT-23,5P,63MIL,PLASTIC,2.9/3.1V,-, -40to+125C,350mA,-,TP"	LP2985AIM5X-3.0
30	U100	1203-002077	IC-VOLTAGE REGULATOR	"2985,SOT-23,5P,63MIL,PLASTIC,3.284/3.416V,-, -40to+125C,350mA,-,TP"	LP2985AIM5X-3.3
31	U301	1204-001811	IC-MELODY	"YMU759-QE2,QFN,32P,-,PLASTIC,6V,-, -20TO+85C,TP,-"	YMU759-QE2

NO	Reference	SEC CODE	Part	Description	Vendor Part No.
32	TH200	1404-001221	THERMISTOR-NTC	"47Kohm,-,4050K,1mW/C,-,-,TP"	NCP15WB473J04RC
33	V400	1405-001082	VARISTOR	"5.6V,20A,1x0.5x0.6mm,TP"	VC040205X150R
34	V401	1405-001082	VARISTOR	"5.6V,20A,1x0.5x0.6mm,TP"	VC040205X150R
35	V315	1405-001093	VARISTOR	"14V,20A,1x0.5x0.6mm,TP"	VC040214X300
36	V201	1405-001110	VARISTOR	"18V,20A,1X0.5X0.6MM,TP"	AVLC 14S 02 050
37	V202	1405-001110	VARISTOR	"18V,20A,1X0.5X0.6MM,TP"	AVLC 14S 02 050
38	R215	2007-000137	R-CHIP	"2Kohm,5%,1/16W,DA,TP,1005"	ERJ2GEJ202X
39	R217	2007-000143	R-CHIP	"4.7Kohm,5%,1/16W,DA,TP,1005"	ERJ2GEJ472X
40	R413	2007-000148	R-CHIP	"10Kohm,5%,1/16W,DA,TP,1005"	ERJ2GEJ103X
41	R712	2007-000148	R-CHIP	"10Kohm,5%,1/16W,DA,TP,1005"	ERJ2GEJ103X
42	R713	2007-000152	R-CHIP	"20Kohm,5%,1/16W,DA,TP,1005"	ERJ2GEJ203X
43	R204	2007-000157	R-CHIP	"47Kohm,5%,1/16W,DA,TP,1005"	ERJ2GEJ473X
44	R422	2007-000157	R-CHIP	"47Kohm,5%,1/16W,DA,TP,1005"	ERJ2GEJ473X
45	R203	2007-000159	R-CHIP	"56Kohm,5%,1/16W,DA,TP,1005"	ERJ2GEJ563X
46	R200	2007-000162	R-CHIP	"100Kohm,5%,1/16W,DA,TP,1005"	ERJ2GEJ104X
47	R201	2007-000162	R-CHIP	"100Kohm,5%,1/16W,DA,TP,1005"	ERJ2GEJ104X
48	R304	2007-000162	R-CHIP	"100Kohm,5%,1/16W,DA,TP,1005"	ERJ2GEJ104X
49	R305	2007-000162	R-CHIP	"100Kohm,5%,1/16W,DA,TP,1005"	ERJ2GEJ104X
50	R416	2007-000162	R-CHIP	"100Kohm,5%,1/16W,DA,TP,1005"	ERJ2GEJ104X
51	R417	2007-000162	R-CHIP	"100Kohm,5%,1/16W,DA,TP,1005"	ERJ2GEJ104X
52	R425	2007-000162	R-CHIP	"100Kohm,5%,1/16W,DA,TP,1005"	ERJ2GEJ104X
53	R426	2007-000162	R-CHIP	"100Kohm,5%,1/16W,DA,TP,1005"	ERJ2GEJ104X
54	R430	2007-000162	R-CHIP	"100Kohm,5%,1/16W,DA,TP,1005"	ERJ2GEJ104X
55	R306	2007-001325	R-CHIP	"3.3Kohm,5%,1/16W,DA,TP,1005"	ERJ2GEJ332X
56	R207	2007-007009	R-CHIP	"75OHM,5%,1/16W,DA,TP,1005"	ERJ2GEJ750X
57	R208	2007-007009	R-CHIP	"75OHM,5%,1/16W,DA,TP,1005"	ERJ2GEJ750X
58	R209	2007-007009	R-CHIP	"75OHM,5%,1/16W,DA,TP,1005"	ERJ2GEJ750X
59	R210	2007-007009	R-CHIP	"75OHM,5%,1/16W,DA,TP,1005"	ERJ2GEJ750X
60	R211	2007-007009	R-CHIP	"75OHM,5%,1/16W,DA,TP,1005"	ERJ2GEJ750X
61	R212	2007-007009	R-CHIP	"75OHM,5%,1/16W,DA,TP,1005"	ERJ2GEJ750X
62	R213	2007-007009	R-CHIP	"75OHM,5%,1/16W,DA,TP,1005"	ERJ2GEJ750X
63	R214	2007-007009	R-CHIP	"75OHM,5%,1/16W,DA,TP,1005"	ERJ2GEJ750X
64	C441	2203-000233	"C-CERAMIC,CHIP"	"0.1nF,5%,50V,NP0,TP,1005"	CM05CG101J50AT
65	C442	2203-000233	"C-CERAMIC,CHIP"	"0.1nF,5%,50V,NP0,TP,1005"	CM05CG101J50AT
66	C103	2203-000254	"C-CERAMIC,CHIP"	"10nF,10%,16V,X7R,TP,1005,-"	CM05X7R103K16AT
67	C113	2203-000254	"C-CERAMIC,CHIP"	"10nF,10%,16V,X7R,TP,1005,-"	CM05X7R103K16AT
68	C114	2203-000254	"C-CERAMIC,CHIP"	"10nF,10%,16V,X7R,TP,1005,-"	CM05X7R103K16AT
69	C402	2203-000254	"C-CERAMIC,CHIP"	"10nF,10%,16V,X7R,TP,1005,-"	CM05X7R103K16AT
70	C412	2203-000254	"C-CERAMIC,CHIP"	"10nF,10%,16V,X7R,TP,1005,-"	CM05X7R103K16AT
71	C413	2203-000254	"C-CERAMIC,CHIP"	"10nF,10%,16V,X7R,TP,1005,-"	CM05X7R103K16AT
72	C414	2203-000254	"C-CERAMIC,CHIP"	"10nF,10%,16V,X7R,TP,1005,-"	CM05X7R103K16AT
73	C419	2203-000254	"C-CERAMIC,CHIP"	"10nF,10%,16V,X7R,TP,1005,-"	CM05X7R103K16AT
74	C420	2203-000254	"C-CERAMIC,CHIP"	"10nF,10%,16V,X7R,TP,1005,-"	CM05X7R103K16AT

NO	Reference	SEC CODE	Part	Description	Vendor Part No.
75	C422	2203-000254	"C-CERAMIC,CHIP"	"10nF,10%,16V,X7R,TP,1005,-"	CM05X7R103K16AT
76	C308	2203-000438	"C-CERAMIC,CHIP"	"1nF,10%,50V,X7R,TP,1005,-"	CM05X7R102K50AH
77	C304	2203-000679	"C-CERAMIC,CHIP"	"0.027nF,5%,50V,NP0,TP,1005"	CM05CG270J50AT
78	C400	2203-000812	"C-CERAMIC,CHIP"	"0.033nF,5%,50V,NP0,TP,1005"	CM05CG330J50AT
79	C401	2203-000812	"C-CERAMIC,CHIP"	"0.033nF,5%,50V,NP0,TP,1005"	CM05CG330J50AT
80	C415	2203-000812	"C-CERAMIC,CHIP"	"0.033nF,5%,50V,NP0,TP,1005"	CM05CG330J50AT
81	C416	2203-000812	"C-CERAMIC,CHIP"	"0.033nF,5%,50V,NP0,TP,1005"	CM05CG330J50AT
82	C417	2203-000812	"C-CERAMIC,CHIP"	"0.033nF,5%,50V,NP0,TP,1005"	CM05CG330J50AT
83	C421	2203-000812	"C-CERAMIC,CHIP"	"0.033nF,5%,50V,NP0,TP,1005"	CM05CG330J50AT
84	C424	2203-000854	"C-CERAMIC,CHIP"	"0.039nF,5%,50V,NP0,TP,1005"	CM05CG390J50AT
85	C432	2203-003054	"C-CERAMIC,CHIP"	"0.009nF,0.25pF,50V,NP0,TP,1005"	C1005CG1H090CT
86	C425	2203-001017	"C-CERAMIC,CHIP"	"0.004nF,0.25pF,50V,NP0,TP,1005"	CM05CG040C50AT
87	C428	2203-001017	"C-CERAMIC,CHIP"	"0.004nF,0.25pF,50V,NP0,TP,1005"	CM05CG040C50AT
88	C203	2203-002443	"C-CERAMIC,CHIP"	"0.33nF,10%,50V,X7R,TP,1005"	CL05B331KBNC
89	C423	2203-003054	"C-CERAMIC,CHIP"	"0.009nF,0.25pF,50V,NP0,TP,1005"	"C-CERAMIC,CHIP"
90	C100	2203-005061	"C-CERAMIC,CHIP"	"100nF,+80-20%,16V,Y5V,TP,1005"	MCH153F104ZK
91	C200	2203-005061	"C-CERAMIC,CHIP"	"100nF,+80-20%,16V,Y5V,TP,1005"	MCH153F104ZK
92	C201	2203-005061	"C-CERAMIC,CHIP"	"100nF,+80-20%,16V,Y5V,TP,1005"	MCH153F104ZK
93	C202	2203-005061	"C-CERAMIC,CHIP"	"100nF,+80-20%,16V,Y5V,TP,1005"	MCH153F104ZK
94	C305	2203-005061	"C-CERAMIC,CHIP"	"100nF,+80-20%,16V,Y5V,TP,1005"	MCH153F104ZK
95	C132	2203-005065	"C-CERAMIC,CHIP"	"1000nF,+80-20%,10V,Y5V,TP,1608"	CL10F105ZPNC
96	C133	2203-005065	"C-CERAMIC,CHIP"	"1000nF,+80-20%,10V,Y5V,TP,1608"	CL10F105ZPNC
97	C102	2404-001105	"C-TA,CHIP"	"10UF,20%,6.3V,GP,TP,2012"	TAJR106M006R
98	C112	2404-001105	"C-TA,CHIP"	"10UF,20%,6.3V,GP,TP,2012"	TAJR106M006R
99	L300	2703-002206	INDUCTOR-SMD	"39NH,5%,1.0X0.5X0.5MM"	CIH05T39NJNC
100	L400	2703-002206	INDUCTOR-SMD	"39NH,5%,1.0X0.5X0.5MM"	CIH05T39NJNC
101	L401	2703-002206	INDUCTOR-SMD	"39NH,5%,1.0X0.5X0.5MM"	CIH05T39NJNC
102	C443	2203-003054	"C-CERAMIC,CHIP"	"0.009nF,0.25pF,50V,NP0,TP,1005"	"C-CERAMIC,CHIP"
103	L402	2703-002206	INDUCTOR-SMD	"39NH,5%,1.0X0.5X0.5MM"	CIH05T39NJNC

3-2 Main Parts List Bottom

NO	Reference	SEC CODE	Part	Description	Vendor Part No.
1	Q700	0504-001058	TR-DIGITAL	"RN4985,NPN/PNP,200mW,2.2Kohm/47Kohm,UMD6,TP"	RN4985-TE85L
2	Q701	0504-001058	TR-DIGITAL	"RN4985,NPN/PNP,200mW,2.2Kohm/47Kohm,UMD6,TP"	RN4985-TE85L
3	U201	0504-001060	TR-DIGITAL	"BCR08PN,NPN/PNP,250mW,2.2Kohm/47Kohm,SOT-363,TP"	BCR08PN
4	Q400	0505-001332	FET-SILICON	"FDG6301,N,25V,0.22A,40HM,.3W,SC70-6"	FDG6301N
5	U101	0505-001423	FET-SILICON	"FDG6323L,N/P,-,-,0.3W,SC70-6"	FDG6323L
6	U105	0506-001004	TR-ARRAY	"UMC5N,NPN/PNP,2,50V,-,-100mA,3"	UMC5NTR
7	U401	1001-001145	IC-ANALOG SWITCH	"MAX4599EXT,-,SC70,6P,49MIL,SINGLE,5.5V,-40to+85C,PLASTIC,245mW,60ohm,25ns,30ns,0"	MAX4599EXT-T
8	U230	1001-001183	IC-ANALOG SWITCH	"MAX4684EUB,-,TSSOP,10P,114MIL,DUAL,3.3V,-40TO+85CC,PLASTIC,444MW,0.8OHM,30NS,50N"	MAX4684EUB
9	U300	1109-001218	IC-ETC. MEMORY	"LRS1806,4MX16/1MX16BIT,BGA,72P,11X8MM,85NS,3V,10%,PLASTIC,-25TO+85C,80UA,CMOS,TR"	LRS1806A
10	U701	1201-001785	IC-POWER AMP	"08122,-,8P,-,DUAL,34DB,-,7V,-,-25TO+100C,-,-,-,-"	PF08122B-10-TB
11	U500	1203-001454	IC-VOLTAGE REGULATOR	"2981,SOT-23,5P,59MIL,PLASTIC,3"	LP2981AIM5X-3.0 4.2#TR
12	U104	1203-002127	IC-BATTERY	"1734,SOT-23,6P,150MIL,PLASTIC,4.7/5.3V,-0to+70C,1A,-,TP"	LTC1734ES6-
13	U106	1203-002247	IC-VOL. DETECTOR	"S-809,SOT-23-5,5P,-,-,-,150MW,-40TO+85C,50MA,-,TP"	S-80926ALMP-DAP-T2
14	U501	1203-002598	IC-VOLTAGE REGULATOR	"2981,SOT-23,5P,2.92X1.6MM,PLASTIC,2.8V,-40TO+125C,100MA,-,TP"	LP2981AIM5X-2.8
15	U112	1203-002599	IC-VOLTAGE REGULATOR	"2981,SOT-23,5P,2.92X1.6MM,PLASTIC,2.5V,-40TO+125C,100MA,-,TP"	LP2981AIM5X-2.5
16	U111	1203-002599	IC-VOLTAGE REGULATOR	"2981,SOT-23,5P,2.92X1.6MM,PLASTIC,2.5V,-40TO+125C,100MA,-,TP"	LP2981AIM5X-2.5
17	U400	1205-002035	IC-COMM. CONTROLLER	"VP40581B,FBGA,180P,-,PLASTIC,3.3V,-,-40TO+85C,TR,ONEC PROCESSOR"	VP40581E3
18	U600	1205-002248	IC-TRANSCEIVER	"SI4200DB-BM,MLP,32P,5X5MM,-,3V,-,-20TO+85C,TP,DUALBAND TRANSCEIVER"	SI4200DB-BM
19	U601	1205-002185	IC-INTERFACE	"SI4201-BM,MLP,20P,4X4MM,-,3V,-,-20TO+85C,TP,UNIVERSAL BASEBAND"	SI4201-BM
20	U702	1209-001379	"IC-ETC, LINEAR"	"HD155173ANPEL,-,16P,-,-,3.4V,240MW,-25TO+85C,TP"	HD155173ANPSEL
21	U503	1209-001434	IC-PLL/SYNTHESISER	"SI4133T-BM,MLP,28P,5X5MM,-,3V,-,-20TO+85C,TP"	SI4133T-BM
22	V300	1405-001082	VARISTOR	"5.6V,20A,1x0.5x0.6mm,TP"	VC040205X150R
23	V301	1405-001082	VARISTOR	"5.6V,20A,1x0.5x0.6mm,TP"	VC040205X150R
24	V403	1405-001082	VARISTOR	"5.6V,20A,1x0.5x0.6mm,TP"	VC040205X150R
25	V404	1405-001082	VARISTOR	"5.6V,20A,1x0.5x0.6mm,TP"	VC040205X150R
26	V405	1405-001082	VARISTOR	"5.6V,20A,1x0.5x0.6mm,TP"	VC040205X150R
27	V310	1405-001093	VARISTOR	"14V,20A,1x0.5x0.6mm,TP"	VC040214X300
28	V309	1405-001093	VARISTOR	"14V,20A,1x0.5x0.6mm,TP"	VC040214X300
29	V308	1405-001093	VARISTOR	"14V,20A,1x0.5x0.6mm,TP"	VC040214X300
30	V307	1405-001093	VARISTOR	"14V,20A,1x0.5x0.6mm,TP"	VC040214X300

NO	Reference	SEC CODE	Part	Description	Vendor Part No.
31	V306	1405-001093	VARISTOR	"14V,20A,1x0.5x0.6mm,TP"	VC040214X300
32	V305	1405-001093	VARISTOR	"14V,20A,1x0.5x0.6mm,TP"	VC040214X300
33	V304	1405-001093	VARISTOR	"14V,20A,1x0.5x0.6mm,TP"	VC040214X300
34	V303	1405-001093	VARISTOR	"14V,20A,1x0.5x0.6mm,TP"	VC040214X300
35	V302	1405-001093	VARISTOR	"14V,20A,1x0.5x0.6mm,TP"	VC040214X300
36	V203	1405-001110	VARISTOR	"18V,20A,1X0.5X0.6MM,TP"	AVLC 14S 02 050
37	R500	2007-000138	R-CHIP	"100ohm,5%,1/16W,DA,TP,1005"	ERJ2GEJ101X
38	R419	2007-000139	R-CHIP	"220ohm,5%,1/16W,DA,TP,1005"	ERJ2GEJ221X
39	R427	2007-000139	R-CHIP	"220ohm,5%,1/16W,DA,TP,1005"	ERJ2GEJ221X
40	R100	2007-000140	R-CHIP	"1Kohm,5%,1/16W,DA,TP,1005"	ERJ2GEJ102X
41	R428	2007-000141	R-CHIP	"2.2Kohm,5%,1/16W,DA,TP,1005"	ERJ2GEJ222X
42	R429	2007-000141	R-CHIP	"2.2Kohm,5%,1/16W,DA,TP,1005"	ERJ2GEJ222X
43	R109	2007-000148	R-CHIP	"10Kohm,5%,1/16W,DA,TP,1005"	ERJ2GEJ103X
44	R300	2007-000148	R-CHIP	"10Kohm,5%,1/16W,DA,TP,1005"	ERJ2GEJ103X
45	R407	2007-000148	R-CHIP	"10Kohm,5%,1/16W,DA,TP,1005"	ERJ2GEJ103X
46	R412	2007-000148	R-CHIP	"10Kohm,5%,1/16W,DA,TP,1005"	ERJ2GEJ103X
47	R415	2007-000148	R-CHIP	"10Kohm,5%,1/16W,DA,TP,1005"	ERJ2GEJ103X
48	R501	2007-000148	R-CHIP	"10Kohm,5%,1/16W,DA,TP,1005"	ERJ2GEJ103X
49	R603	2007-000148	R-CHIP	"10Kohm,5%,1/16W,DA,TP,1005"	ERJ2GEJ103X
50	R711	2007-000148	R-CHIP	"10Kohm,5%,1/16W,DA,TP,1005"	ERJ2GEJ103X
51	R311	2007-000148	R-CHIP	"10Kohm,5%,1/16W,DA,TP,1005"	ERJ2GEJ103X
52	R418	2007-000152	R-CHIP	"20Kohm,5%,1/16W,DA,TP,1005"	ERJ2GEJ203X
53	R714	2007-000152	R-CHIP	"20Kohm,5%,1/16W,DA,TP,1005"	ERJ2GEJ203X
54	R105	2007-000162	R-CHIP	"100Kohm,5%,1/16W,DA,TP,1005"	ERJ2GEJ104X
55	R106	2007-000162	R-CHIP	"100Kohm,5%,1/16W,DA,TP,1005"	ERJ2GEJ104X
56	R107	2007-000162	R-CHIP	"100Kohm,5%,1/16W,DA,TP,1005"	ERJ2GEJ104X
57	R108	2007-000162	R-CHIP	"100Kohm,5%,1/16W,DA,TP,1005"	ERJ2GEJ104X
58	R110	2007-000162	R-CHIP	"100Kohm,5%,1/16W,DA,TP,1005"	ERJ2GEJ104X
59	R301	2007-000162	R-CHIP	"100Kohm,5%,1/16W,DA,TP,1005"	ERJ2GEJ104X
60	R302	2007-000162	R-CHIP	"100Kohm,5%,1/16W,DA,TP,1005"	ERJ2GEJ104X
61	R303	2007-000162	R-CHIP	"100Kohm,5%,1/16W,DA,TP,1005"	ERJ2GEJ104X
62	R408	2007-000162	R-CHIP	"100Kohm,5%,1/16W,DA,TP,1005"	ERJ2GEJ104X
63	R410	2007-000162	R-CHIP	"100Kohm,5%,1/16W,DA,TP,1005"	ERJ2GEJ104X
64	R411	2007-000162	R-CHIP	"100Kohm,5%,1/16W,DA,TP,1005"	ERJ2GEJ104X
65	R421	2007-000162	R-CHIP	"100Kohm,5%,1/16W,DA,TP,1005"	ERJ2GEJ104X
66	R432	2007-000162	R-CHIP	"100Kohm,5%,1/16W,DA,TP,1005"	ERJ2GEJ104X
67	R435	2007-000162	R-CHIP	"100Kohm,5%,1/16W,DA,TP,1005"	ERJ2GEJ104X
68	R437	2007-000162	R-CHIP	"100Kohm,5%,1/16W,DA,TP,1005"	ERJ2GEJ104X
69	R438	2007-000162	R-CHIP	"100Kohm,5%,1/16W,DA,TP,1005"	ERJ2GEJ104X
70	R312	2007-000162	R-CHIP	"100Kohm,5%,1/16W,DA,TP,1005"	ERJ2GEJ104X
71	R423	2007-000168	R-CHIP	"470Kohm,5%,1/16W,DA,TP,1005"	ERJ2GEJ474X
72	R609	2007-000242	R-CHIP	"1.5Kohm,5%,1/16W,DA,TP,1005"	ERJ2GEJ152X
73	R101	2007-000831	R-CHIP	"39Kohm,5%,1/16W,DA,TP,1005"	ERJ2GEJ393X

NO	Reference	SEC CODE	Part	Description	Vendor Part No.
74	R706	2007-001217	R-CHIP	"82ohm,5%,1/16W,DA,TP,1005"	ERJ2GEJ820X
75	R707	2007-001217	R-CHIP	"82ohm,5%,1/16W,DA,TP,1005"	ERJ2GEJ820X
76	R600	2007-001295	R-CHIP	"39ohm,5%,1/16W,DA,TP,1005"	ERJ2GEJ390X
77	R604	2007-001295	R-CHIP	"39ohm,5%,1/16W,DA,TP,1005"	ERJ2GEJ390X
78	R502	2007-001298	R-CHIP	"51ohm,5%,1/16W,DA,TP,1005"	ERJ2GEJ510X
79	R503	2007-001298	R-CHIP	"51ohm,5%,1/16W,DA,TP,1005"	ERJ2GEJ510X
80	R504	2007-001298	R-CHIP	"51ohm,5%,1/16W,DA,TP,1005"	ERJ2GEJ510X
81	R505	2007-001298	R-CHIP	"51ohm,5%,1/16W,DA,TP,1005"	ERJ2GEJ510X
82	R709	2007-001301	R-CHIP	"68ohm,5%,1/16W,DA,TP,1005"	ERJ2GEJ680X
83	R710	2007-001301	R-CHIP	"68ohm,5%,1/16W,DA,TP,1005"	ERJ2GEJ680X
84	R611	2007-001305	R-CHIP	"120ohm,5%,1/16W,DA,TP,1005"	ERJ2GEJ121X
85	R704	2007-001305	R-CHIP	"120ohm,5%,1/16W,DA,TP,1005"	ERJ2GEJ121X
86	R420	2007-002796	R-CHIP	"510ohm,5%,1/16W,DA,TP,1005"	ERJ2GEJ511X
87	R424	2007-002796	R-CHIP	"510ohm,5%,1/16W,DA,TP,1005"	ERJ2GEJ511X
88	R219	2007-003001	R-CHIP	"120HM,5%,1/16W,DA,TP,1005"	TSR16GJ120V
89	R220	2007-003001	R-CHIP	"120HM,5%,1/16W,DA,TP,1005"	TSR16GJ120V
90	R104	2007-007107	R-CHIP	"100Kohm,1%,1/16W,DA,TP,1005"	MCR01MZSF1003
91	R700	2007-007142	R-CHIP	"10Kohm,1%,1/16W,DA,TP,1005"	ERJ2RKF103X
92	R701	2007-007142	R-CHIP	"10Kohm,1%,1/16W,DA,TP,1005"	ERJ2RKF103X
93	R705	2007-007142	R-CHIP	"10Kohm,1%,1/16W,DA,TP,1005"	ERJ2RKF103X
94	R601	2007-007307	R-CHIP	"150ohm,1%,1/16W,DA,TP,1005"	RK73H1ETP1500F
95	R602	2007-007307	R-CHIP	"150ohm,1%,1/16W,DA,TP,1005"	RK73H1ETP1500F
96	R606	2007-007307	R-CHIP	"150ohm,1%,1/16W,DA,TP,1005"	RK73H1ETP1500F
97	R607	2007-007307	R-CHIP	"150ohm,1%,1/16W,DA,TP,1005"	RK73H1ETP1500F
98	R708	2007-007307	R-CHIP	"150ohm,1%,1/16W,DA,TP,1005"	RK73H1ETP1500F
99	R703	2007-007311	R-CHIP	"22Kohm,1%,1/16W,DA,TP,1005"	RK73H1ETP2202F
100	R401	2007-007317	R-CHIP	"2.2Kohm,1%,1/16W,DA,TP,1005"	MCR01MZSF2201
101	R400	2007-007317	R-CHIP	"2.2Kohm,1%,1/16W,DA,TP,1005"	MCR01MZSF2201
102	R221	2007-007318	R-CHIP	"1Kohm,1%,1/16W,DA,TP,1005"	MCR01MZSF1001
103	R222	2007-007318	R-CHIP	"1Kohm,1%,1/16W,DA,TP,1005"	MCR01MZSF1001
104	R223	2007-007318	R-CHIP	"1Kohm,1%,1/16W,DA,TP,1005"	MCR01MZSF1001
105	R224	2007-007318	R-CHIP	"1Kohm,1%,1/16W,DA,TP,1005"	MCR01MZSF1001
106	R225	2007-007318	R-CHIP	"1Kohm,1%,1/16W,DA,TP,1005"	MCR01MZSF1001
107	R226	2007-007318	R-CHIP	"1Kohm,1%,1/16W,DA,TP,1005"	MCR01MZSF1001
108	R227	2007-007318	R-CHIP	"1Kohm,1%,1/16W,DA,TP,1005"	MCR01MZSF1001
109	R228	2007-007318	R-CHIP	"1Kohm,1%,1/16W,DA,TP,1005"	MCR01MZSF1001
110	R229	2007-007318	R-CHIP	"1Kohm,1%,1/16W,DA,TP,1005"	MCR01MZSF1001
111	R404	2007-007318	R-CHIP	"1Kohm,1%,1/16W,DA,TP,1005"	MCR01MZSF1001
112	R405	2007-007318	R-CHIP	"1Kohm,1%,1/16W,DA,TP,1005"	MCR01MZSF1001
113	R406	2007-007318	R-CHIP	"1Kohm,1%,1/16W,DA,TP,1005"	MCR01MZSF1001
114	R409	2007-007318	R-CHIP	"1Kohm,1%,1/16W,DA,TP,1005"	MCR01MZSF1001
115	R102	2007-007590	R-CHIP	"82Kohm,1%,1/16W,DA,TP,1005"	RK73H1ETP8202F
116	R113	2007-007771	R-CHIP	"0OHM,5%,1/16W,DA,TP,1005"	ERJ2GEJ0R0E

NO	Reference	SEC CODE	Part	Description	Vendor Part No.
117	R608	2007-007771	R-CHIP	"00HM,5%, 1/16W,DA,TP,1005"	ERJ2GEJ0R0E
118	R103	2007-008117	R-CHIP	"2.7Kohm,1%, 1/16W,DA,TP,1005"	RK73H1ETP2701F
119	R402	2007-008117	R-CHIP	"2.7Kohm,1%, 1/16W,DA,TP,1005"	RK73H1ETP2701F
120	R403	2007-008117	R-CHIP	"2.7Kohm,1%, 1/16W,DA,TP,1005"	RK73H1ETP2701F
121	R702	2007-008117	R-CHIP	"2.7Kohm,1%, 1/16W,DA,TP,1005"	RK73H1ETP2701F
122	R439	2011-001345	R-NETWORK	"10Kohm,5%, 1/16W,L,CHIP,8P,TP"	EXB28V103JX
123	C405	2203-000233	"C-CERAMIC,CHIP"	"0.1nF,5%,50V,NP0,TP,1005"	CM05CG101J50AT
124	C406	2203-000233	"C-CERAMIC,CHIP"	"0.1nF,5%,50V,NP0,TP,1005"	CM05CG101J50AT
125	C407	2203-000233	"C-CERAMIC,CHIP"	"0.1nF,5%,50V,NP0,TP,1005"	CM05CG101J50AT
126	C408	2203-000233	"C-CERAMIC,CHIP"	"0.1nF,5%,50V,NP0,TP,1005"	CM05CG101J50AT
127	C509	2203-000233	"C-CERAMIC,CHIP"	"0.1nF,5%,50V,NP0,TP,1005"	CM05CG101J50AT
128	C514	2203-000233	"C-CERAMIC,CHIP"	"0.1nF,5%,50V,NP0,TP,1005"	CM05CG101J50AT
129	C604	2203-000233	"C-CERAMIC,CHIP"	"0.1nF,5%,50V,NP0,TP,1005"	CM05CG101J50AT
130	C701	2203-000233	"C-CERAMIC,CHIP"	"0.1nF,5%,50V,NP0,TP,1005"	CM05CG101J50AT
131	C705	2203-000233	"C-CERAMIC,CHIP"	"0.1nF,5%,50V,NP0,TP,1005"	CM05CG101J50AT
132	C104	2203-000254	"C-CERAMIC,CHIP"	"10nF,10%,16V,X7R,TP,1005,-"	CM05X7R103K16AT
133	C302	2203-000254	"C-CERAMIC,CHIP"	"10nF,10%,16V,X7R,TP,1005,-"	CM05X7R103K16AT
134	C411	2203-000254	"C-CERAMIC,CHIP"	"10nF,10%,16V,X7R,TP,1005,-"	CM05X7R103K16AT
135	C508	2203-000254	"C-CERAMIC,CHIP"	"10nF,10%,16V,X7R,TP,1005,-"	CM05X7R103K16AT
136	C512	2203-000254	"C-CERAMIC,CHIP"	"10nF,10%,16V,X7R,TP,1005,-"	CM05X7R103K16AT
137	C513	2203-000254	"C-CERAMIC,CHIP"	"10nF,10%,16V,X7R,TP,1005,-"	CM05X7R103K16AT
138	C704	2203-000311	"C-CERAMIC,CHIP"	"0.12nF,5%,50V,NP0,TP,1005"	CM105CG121J50AT
139	C702	2203-000438	"C-CERAMIC,CHIP"	"1nF,10%,50V,X7R,TP,1005,-"	CM05X7R102K50AH
140	C713	2203-000438	"C-CERAMIC,CHIP"	"1nF,10%,50V,X7R,TP,1005,-"	CM05X7R102K50AH
141	C712	2203-002668	"C-CERAMIC,CHIP"	"0.0005nF,0.1pF,50V,NP0,TP,1005"	C1005CG1H0R5BT
142	C716	2203-000628	"C-CERAMIC,CHIP"	"0.022nF,5%,50V,NP0,TP,1005"	GRP1555C1H220JZ01E
143	C708	2203-000654	"C-CERAMIC,CHIP"	"270pF,10%,50V,X7R,TP,1005,-"	CM05X7R271K50AH
144	C204	2203-000679	"C-CERAMIC,CHIP"	"0.027nF,5%,50V,NP0,TP,1005"	CM05CG270J50AT
145	C205	2203-000679	"C-CERAMIC,CHIP"	"0.027nF,5%,50V,NP0,TP,1005"	CM05CG270J50AT
146	C206	2203-000679	"C-CERAMIC,CHIP"	"0.027nF,5%,50V,NP0,TP,1005"	CM05CG270J50AT
147	C207	2203-000679	"C-CERAMIC,CHIP"	"0.027nF,5%,50V,NP0,TP,1005"	CM05CG270J50AT
148	C208	2203-000679	"C-CERAMIC,CHIP"	"0.027nF,5%,50V,NP0,TP,1005"	CM05CG270J50AT
149	C209	2203-000679	"C-CERAMIC,CHIP"	"0.027nF,5%,50V,NP0,TP,1005"	CM05CG270J50AT
150	C210	2203-000679	"C-CERAMIC,CHIP"	"0.027nF,5%,50V,NP0,TP,1005"	CM05CG270J50AT
151	C211	2203-000679	"C-CERAMIC,CHIP"	"0.027nF,5%,50V,NP0,TP,1005"	CM05CG270J50AT
152	C212	2203-000679	"C-CERAMIC,CHIP"	"0.027nF,5%,50V,NP0,TP,1005"	CM05CG270J50AT
153	C213	2203-000679	"C-CERAMIC,CHIP"	"0.027nF,5%,50V,NP0,TP,1005"	CM05CG270J50AT
154	C230	2203-000679	"C-CERAMIC,CHIP"	"0.027nF,5%,50V,NP0,TP,1005"	CM05CG270J50AT
155	C231	2203-000679	"C-CERAMIC,CHIP"	"0.027nF,5%,50V,NP0,TP,1005"	CM05CG270J50AT
156	C232	2203-000679	"C-CERAMIC,CHIP"	"0.027nF,5%,50V,NP0,TP,1005"	CM05CG270J50AT
157	C233	2203-000679	"C-CERAMIC,CHIP"	"0.027nF,5%,50V,NP0,TP,1005"	CM05CG270J50AT
158	C235	2203-000679	"C-CERAMIC,CHIP"	"0.027nF,5%,50V,NP0,TP,1005"	CM05CG270J50AT
159	C236	2203-000679	"C-CERAMIC,CHIP"	"0.027nF,5%,50V,NP0,TP,1005"	CM05CG270J50AT

NO	Reference	SEC CODE	Part	Description	Vendor Part No.
160	C237	2203-000679	"C-CERAMIC,CHIP"	"0.027nF,5%,50V,NP0,TP,1005"	CM05CG270J50AT
161	C240	2203-000679	"C-CERAMIC,CHIP"	"0.027nF,5%,50V,NP0,TP,1005"	CM05CG270J50AT
162	C300	2203-000679	"C-CERAMIC,CHIP"	"0.027nF,5%,50V,NP0,TP,1005"	CM05CG270J50AT
163	C316	2203-000679	"C-CERAMIC,CHIP"	"0.027nF,5%,50V,NP0,TP,1005"	CM05CG270J50AT
164	C427	2203-000679	"C-CERAMIC,CHIP"	"0.027nF,5%,50V,NP0,TP,1005"	CM05CG270J50AT
165	C435	2203-005382	"C-CERAMIC,CHIP"	"0.006nF,0.1pF,50V,NP0,TP,1005"	GRP1555C1H6R0BZ01E
166	C436	2203-005382	"C-CERAMIC,CHIP"	"0.006nF,0.1pF,50V,NP0,TP,1005"	GRP1555C1H6R0BZ01E
167	FC501	2203-000679	"C-CERAMIC,CHIP"	"0.027nF,5%,50V,NP0,TP,1005"	CM05CG270J50AT
168	C507	2203-000679	"C-CERAMIC,CHIP"	"0.027nF,5%,50V,NP0,TP,1005"	CM05CG270J50AT
169	C707	2203-000679	"C-CERAMIC,CHIP"	"0.027nF,5%,50V,NP0,TP,1005"	CM05CG270J50AT
170	C709	2203-000679	"C-CERAMIC,CHIP"	"0.027nF,5%,50V,NP0,TP,1005"	CM05CG270J50AT
171	C717	2203-000679	"C-CERAMIC,CHIP"	"0.027nF,5%,50V,NP0,TP,1005"	CM05CG270J50AT
172	C118	2203-000800	"C-CERAMIC,CHIP"	"33nF,10%,25V,X7R,TP,1608"	GRM188R71E333KA01D
173	C418	2203-000812	"C-CERAMIC,CHIP"	"0.033nF,5%,50V,NP0,TP,1005"	CM05CG330J50AT
174	C607	2203-000812	"C-CERAMIC,CHIP"	"0.033nF,5%,50V,NP0,TP,1005"	CM05CG330J50AT
175	C611	2203-000812	"C-CERAMIC,CHIP"	"0.033nF,5%,50V,NP0,TP,1005"	CM05CG330J50AT
176	C710	2203-000812	"C-CERAMIC,CHIP"	"0.033nF,5%,50V,NP0,TP,1005"	CM05CG330J50AT
177	C714	2203-000812	"C-CERAMIC,CHIP"	"0.033nF,5%,50V,NP0,TP,1005"	CM05CG330J50AT
178	C715	2203-000812	"C-CERAMIC,CHIP"	"0.033nF,5%,50V,NP0,TP,1005"	CM05CG330J50AT
179	C703	2203-000836	"C-CERAMIC,CHIP"	"390pF,10%,50V,X7R,TP,1005,-"	CM05X7R391K50AT
180	C433	2203-000854	"C-CERAMIC,CHIP"	"0.039nF,5%,50V,NP0,TP,1005"	CM05CG390J50AT
181	C490	2203-000854	"C-CERAMIC,CHIP"	"0.039nF,5%,50V,NP0,TP,1005"	CM05CG390J50AT
182	C491	2203-000854	"C-CERAMIC,CHIP"	"0.039nF,5%,50V,NP0,TP,1005"	CM05CG390J50AT
183	C711	2203-000870	"C-CERAMIC,CHIP"	"0.003nF,0.25pF,50V,NP0,TP,1005"	CM05CG030C50AT
184	C430	2203-000995	"C-CERAMIC,CHIP"	"0.047nF,5%,50V,NP0,TP,1005"	CM05CG470J50AT
185	C706	2203-000995	"C-CERAMIC,CHIP"	"0.047nF,5%,50V,NP0,TP,1005"	CM05CG470J50AT
186	C510	2203-001405	"C-CERAMIC,CHIP"	"22nF,+80-20%,25V,Y5V,TP,1005"	04023G223ZAT2A
187	C511	2203-001405	"C-CERAMIC,CHIP"	"22nF,+80-20%,25V,Y5V,TP,1005"	04023G223ZAT2A
188	C600	2203-001405	"C-CERAMIC,CHIP"	"22nF,+80-20%,25V,Y5V,TP,1005"	04023G223ZAT2A
189	C601	2203-001405	"C-CERAMIC,CHIP"	"22nF,+80-20%,25V,Y5V,TP,1005"	04023G223ZAT2A
190	C608	2203-001405	"C-CERAMIC,CHIP"	"22nF,+80-20%,25V,Y5V,TP,1005"	04023G223ZAT2A
191	C609	2203-001405	"C-CERAMIC,CHIP"	"22nF,+80-20%,25V,Y5V,TP,1005"	04023G223ZAT2A
192	C610	2203-001405	"C-CERAMIC,CHIP"	"22nF,+80-20%,25V,Y5V,TP,1005"	04023G223ZAT2A
193	C612	2203-001405	"C-CERAMIC,CHIP"	"22nF,+80-20%,25V,Y5V,TP,1005"	04023G223ZAT2A
194	C605	2203-005050	"C-CERAMIC,CHIP"	"0.0018nF,0.25pF,50V,NP0,TP,1005"	CM05CG1R8C50AT
195	C606	2203-005050	"C-CERAMIC,CHIP"	"0.0018nF,0.25pF,50V,NP0,TP,1005"	CM05CG1R8C50AT
196	C110	2203-005061	"C-CERAMIC,CHIP"	"100nF,+80-20%,16V,Y5V,TP,1005"	MCH153F104ZK
197	C111	2203-005061	"C-CERAMIC,CHIP"	"100nF,+80-20%,16V,Y5V,TP,1005"	MCH153F104ZK
198	C117	2203-005061	"C-CERAMIC,CHIP"	"100nF,+80-20%,16V,Y5V,TP,1005"	MCH153F104ZK
199	C119	2203-005061	"C-CERAMIC,CHIP"	"100nF,+80-20%,16V,Y5V,TP,1005"	MCH153F104ZK
200	C301	2203-005061	"C-CERAMIC,CHIP"	"100nF,+80-20%,16V,Y5V,TP,1005"	MCH153F104ZK
201	C500	2203-005061	"C-CERAMIC,CHIP"	"100nF,+80-20%,16V,Y5V,TP,1005"	MCH153F104ZK
202	C504	2203-005061	"C-CERAMIC,CHIP"	"100nF,+80-20%,16V,Y5V,TP,1005"	MCH153F104ZK

NO	Reference	SEC CODE	Part	Description	Vendor Part No.
203	C105	2203-005065	"C-CERAMIC,CHIP"	"1000nF,+80-20%,10V,Y5V,TP,1608"	CL10F105ZPNC
204	C107	2203-005065	"C-CERAMIC,CHIP"	"1000nF,+80-20%,10V,Y5V,TP,1608"	CL10F105ZPNC
205	C130	2203-005065	"C-CERAMIC,CHIP"	"1000nF,+80-20%,10V,Y5V,TP,1608"	CL10F105ZPNC
206	C501	2203-005065	"C-CERAMIC,CHIP"	"1000nF,+80-20%,10V,Y5V,TP,1608"	CL10F105ZPNC
207	C505	2203-005065	"C-CERAMIC,CHIP"	"1000nF,+80-20%,10V,Y5V,TP,1608"	CL10F105ZPNC
208	C602	2203-005234	"C-CERAMIC,CHIP"	"0.0012nF,0.25pF,50V,NP0,TP,1005"	GRP1555C1H1R2CZ01E
209	C603	2203-005234	"C-CERAMIC,CHIP"	"0.0012nF,0.25pF,50V,NP0,TP,1005"	GRP1555C1H1R2CZ01E
210	C429	2203-005480	"C-CERAMIC,CHIP"	"33nF,10%,10V,X7R,TP,1005,-"	GRP155R71A333KA01E
211	C434	2203-005480	"C-CERAMIC,CHIP"	"33nF,10%,10V,X7R,TP,1005,-"	GRP155R71A333KA01E
212	C438	2203-005481	"C-CERAMIC,CHIP"	"47nF,10%,10V,X7R,TP,1005,-"	GRP155R71A473KA01E
213	C409	2203-005503	"C-CERAMIC,CHIP"	"0.18nF,5%,25V,NP0,TP,1005"	GRP1556C1E181JD01E
214	C410	2203-005503	"C-CERAMIC,CHIP"	"0.18nF,5%,25V,NP0,TP,1005"	GRP1556C1E181JD01E
215	C115	2404-001020	"C-TA,CHIP"	"10uF,20%,10V,GP,TP,3216,3.2"	TMCMA1A106MTR
216	C108	2404-001105	"C-TA,CHIP"	"10UF,20%,6.3V,GP,TP,2012"	TAJR106M006R
217	C109	2404-001105	"C-TA,CHIP"	"10UF,20%,6.3V,GP,TP,2012"	TAJR106M006R
218	C116	2404-001105	"C-TA,CHIP"	"10UF,20%,6.3V,GP,TP,2012"	TAJR106M006R
219	C502	2404-001105	"C-TA,CHIP"	"10UF,20%,6.3V,GP,TP,2012"	TAJR106M006R
220	C506	2404-001105	"C-TA,CHIP"	"10UF,20%,6.3V,GP,TP,2012"	TAJR106M006R
221	C431	2404-001162	"C-TA,CHIP"	"47uF,20%,4V,LZ,TP,3216"	F950G476MAAJZTQ2
222	C101	2404-001239	"C-TA,CHIP"	"100UF,20%,6.3V,WT,TP,3.3X2.7X1.7MM"	F950J107MBAAQ2
223	C700	2404-001280	"C-TA,CHIP"	"220UF,20%,6.3V,LZ,TP,7132"	F750J227MUCGZT
224	L501	2703-001943	INDUCTOR-SMD	"10nH,5%,1.0x0.5x0.5mm"	HK1005-10NJ-T
225	L701	2703-001943	INDUCTOR-SMD	"10nH,5%,1.0x0.5x0.5mm"	HK1005-10NJ-T
226	L500	2703-002205	INDUCTOR-SMD	"3.9NH,10%,1.0X0.5X0.5MM"	CIH05T3N9KNC
227	L700	2703-002267	INDUCTOR-SMD	"4.7NH,0.3NH,1.0X0.5X0.5MM"	CIH05T4N7SNC
228	L600	2703-002484	INDUCTOR-SMD	"7.5NH,5%,1.0X0.5X0.5MM"	0402CS-7N5XJBW
229	L601	2703-002485	INDUCTOR-SMD	"27NH,5%,1.0X0.5X0.5MM"	0402CS-27NXJBW
230	OSC400	2801-004025	CRYSTAL-UNIT	"0.032768MHz,20ppm,28-ABK, 1.7fF,65kohm,TP"	FC-255
231	U502	2809-001260	OSCILLATOR-VCTCXO	"13MHZ,3PPM,10KOHM//10PF,TP,3V,-"	TCO-9141B(13MHZ)
232	F600	2904-001387	FILTER-SAW	"1.8425GHZ,-,1.1DB,TP, 1805-1880MHZ/3.0DB,-"	B7716
233	F601	2904-001417	FILTER-SAW	"942.5MHZ,-,0.8DB,TP,925. 0-960.0MHZ/1.9DB,-"	B7820
234	U704	2909-001146	FILTER-DUPLEXER	"942.5MHZ,897.5MHZ,1.4/1.5DB,TP,-,-"	LMG002S-5008C
235	CON700	3705-001242	CONNECTOR-COAXIAL	"-,JACK,100MOHM,50OHM,-"	CRS5001-1702
236	CN100	3709-001187	CONNECTOR-CARD EDGE	"6P,2.54MM,SMD-A,-"	CLE1006-0902G
237	CN300	3710-001816	CONNECTOR-SOCKET	"18P,1R,0.5MM,ANGLE,AU"	1004-0018-319
238	CN200	3711-004980	CONNECTOR-HEADER	"NO,26P,2R,0.5MM,SMD-S,AU,NTR"	AXK6F26335J
239	EAR400	3722-001715	JACK-PHONE	"6P,2.3PI,AU,BLK,-"	02-828P0-53BKA
240	C106	4302-001119	BATTERY-LI(2ND)	"3V,0.1MAH,-,-,3.1V,-"	ML414R-TT30
241	U703	4709-001213	COUPLER-DIRECTION	"1710-1785MHz,14+-1dB,12dB,	DCS214E-1747

NO	Reference	SEC CODE	Part	Description	Vendor Part No.
				2.0X1.25X0.7mm,TP”	
242	U700	4709-001214	COUPLER-DIRECTION	“880-915MHz,19.5+-1dB, 13dB,2.0X1.25X0.7mm,TP”	DCS214E-0897
243	ANT700	GH61-00026A	SPRING ETC-ANT. CONTACT	“SGH-N620,BE-CU,-,-,-,-,-,GLD,-,-”	
244		GH73-01322A	RMO-RUBBER ANT CONTACT	“SPH-X7700,CR RUBBER, 3X4XT1.0,-,-,BLK,-,-,-,-”	

4. Block Diagrams

4-1 Main Base Band

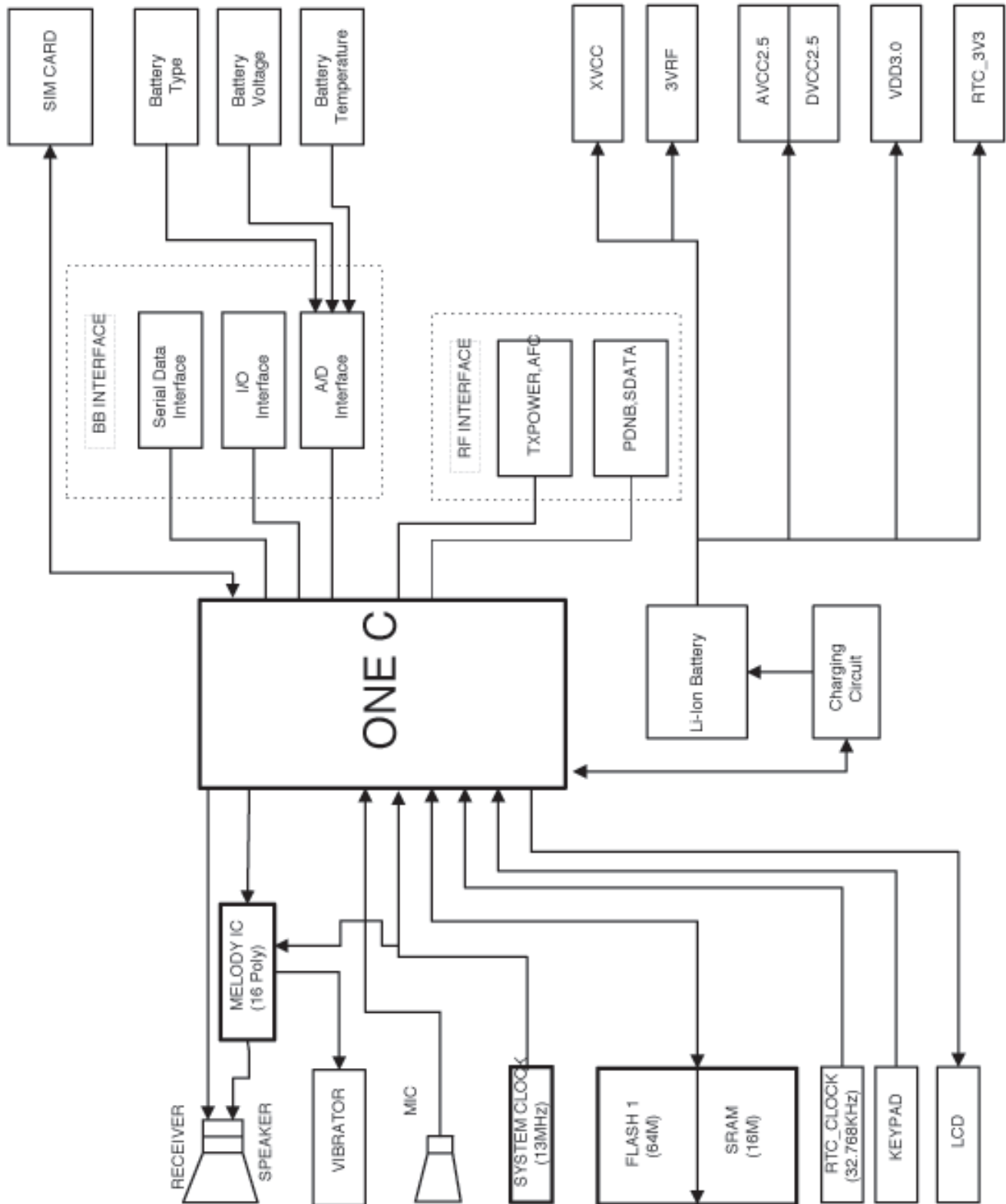

4-2 Main RF

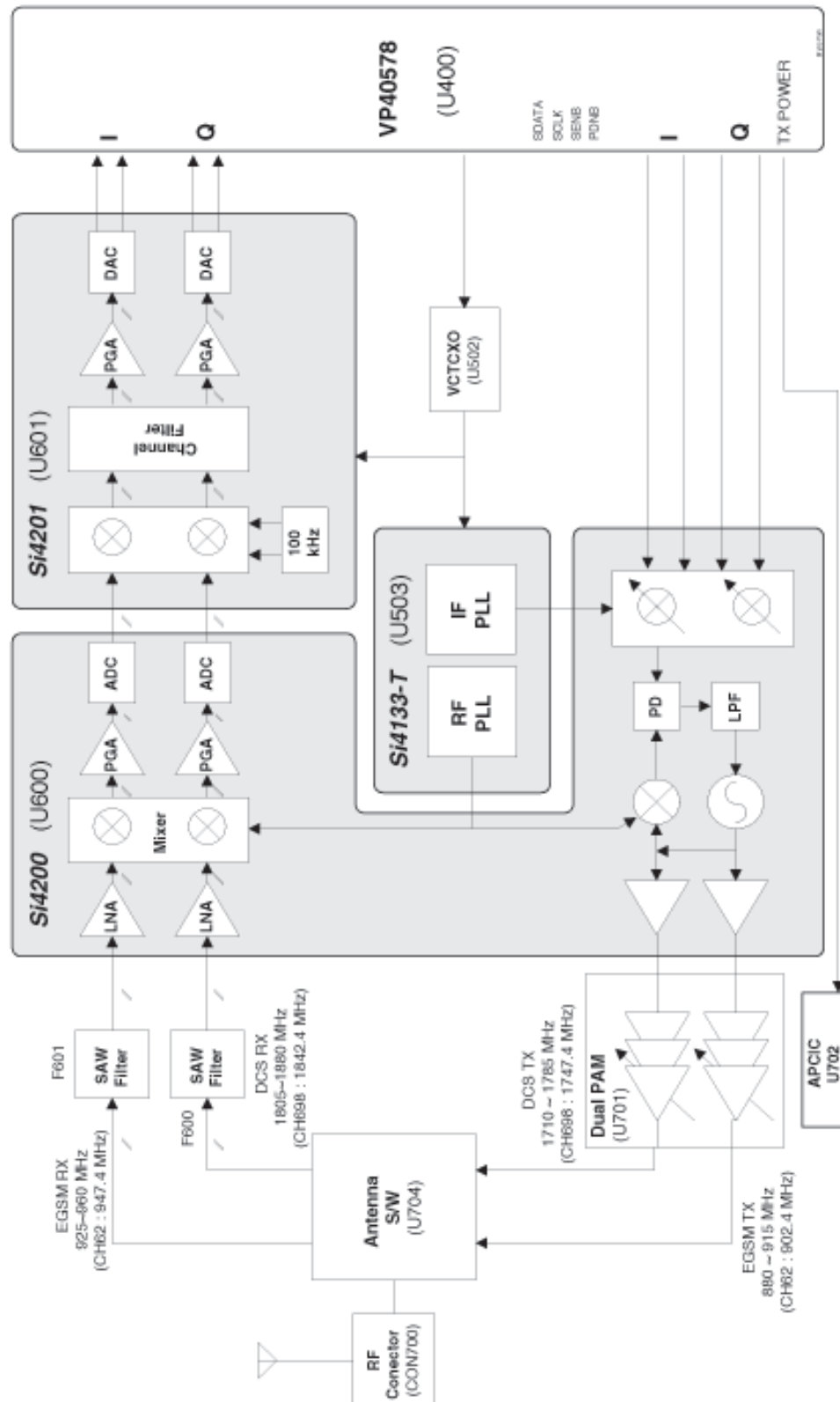

4-2-1 RF Transmit Part

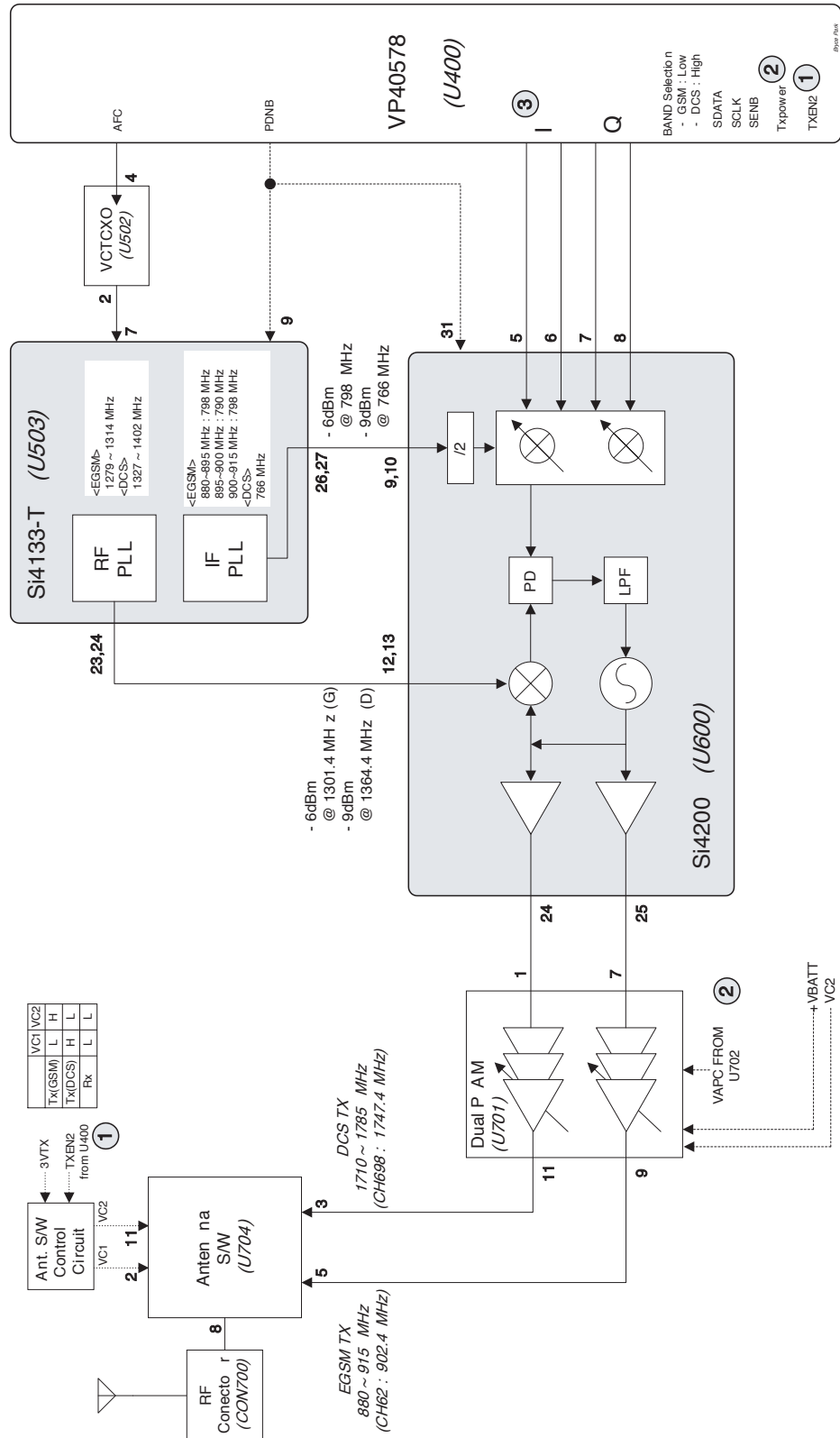

5. Flow Chart of Troubleshooting and Circuit Diagram

5-1 Power ON

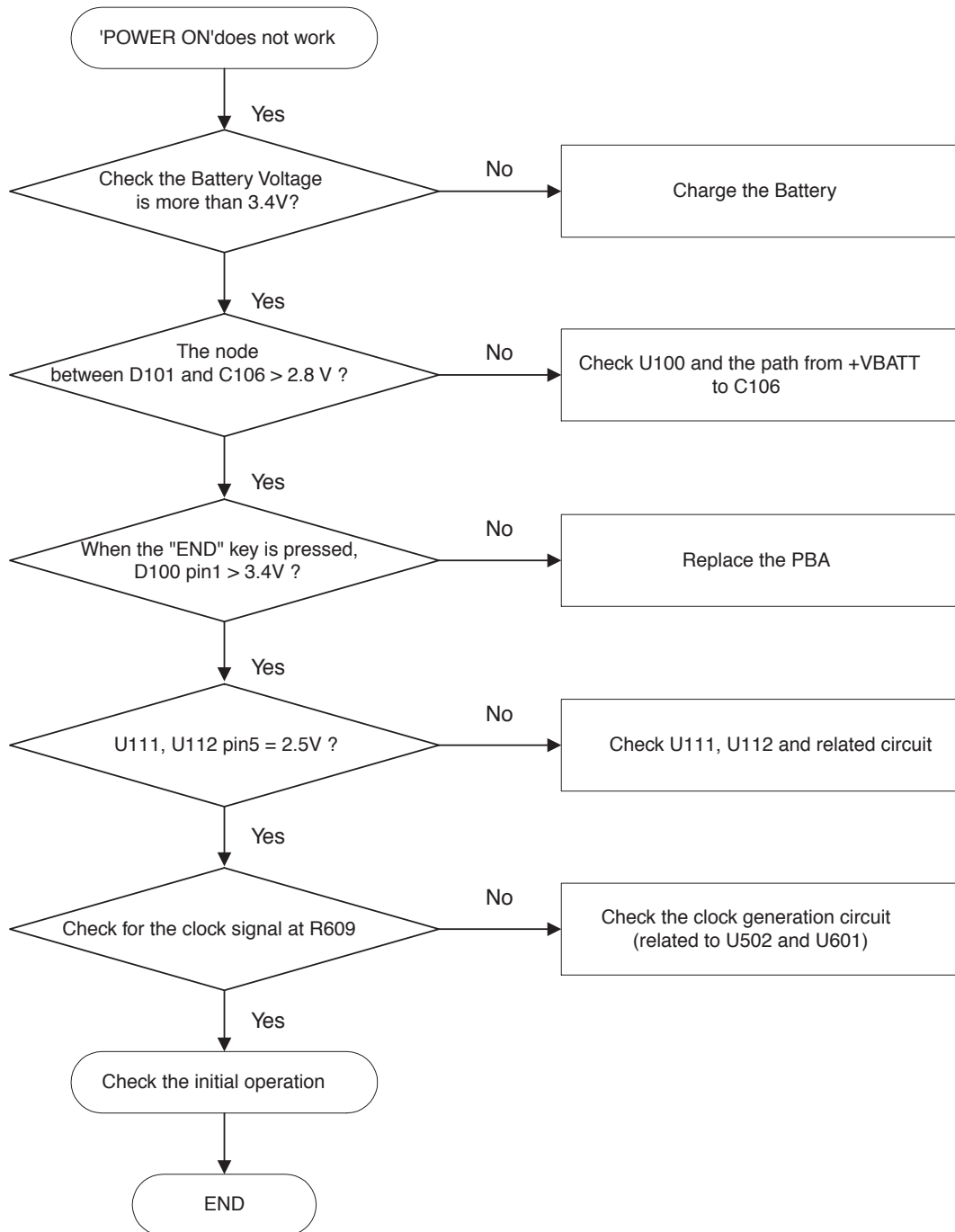

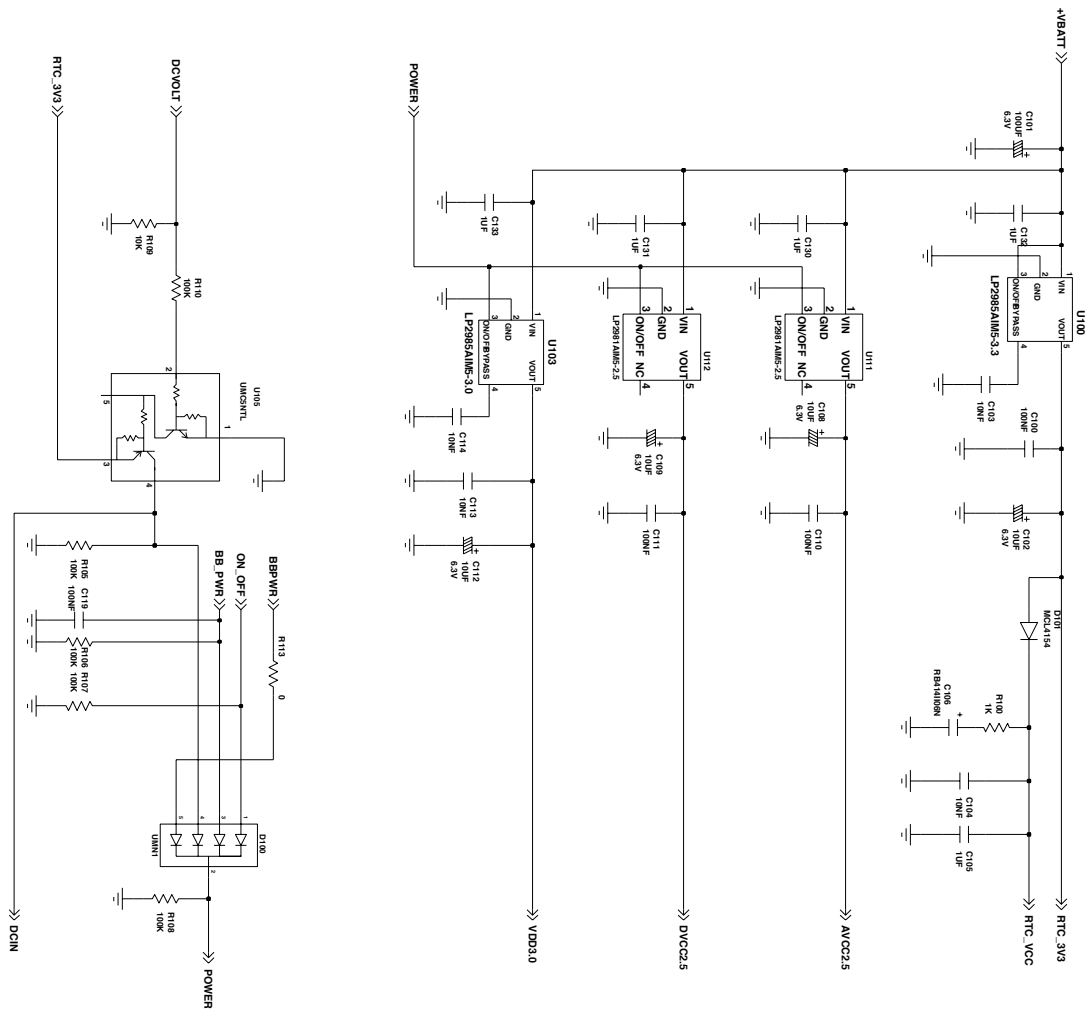

5-2 Initial

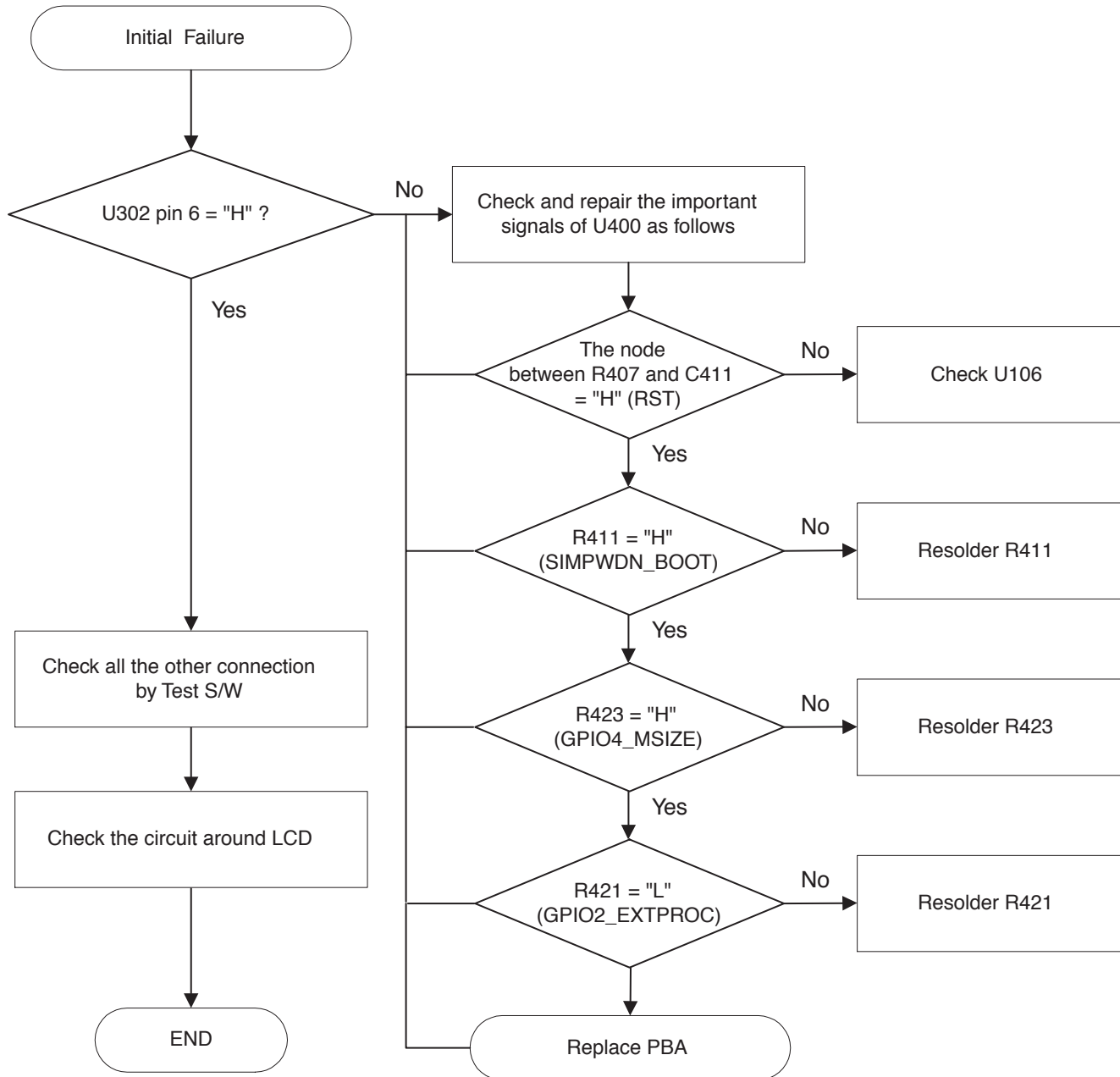

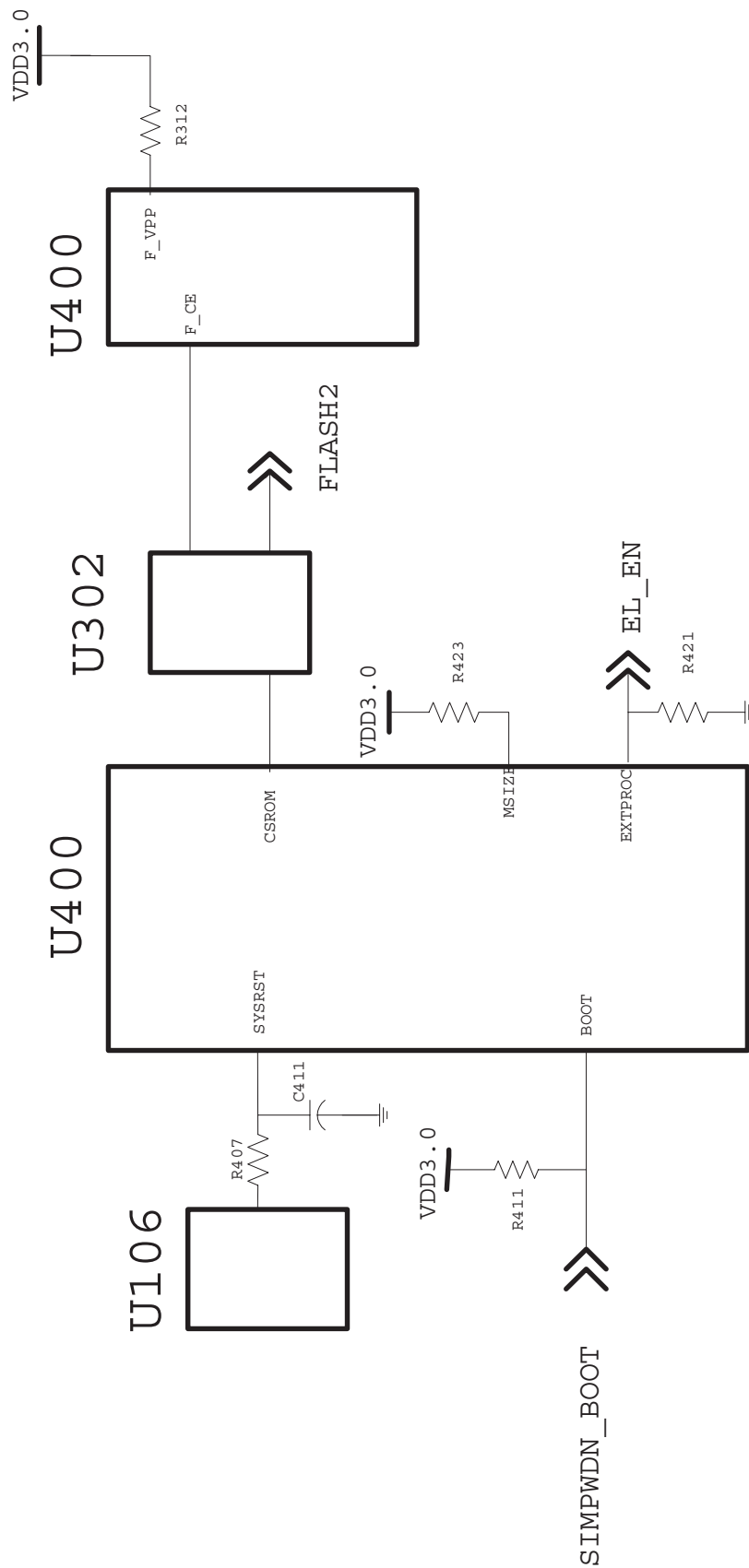

5-3 Charging Part

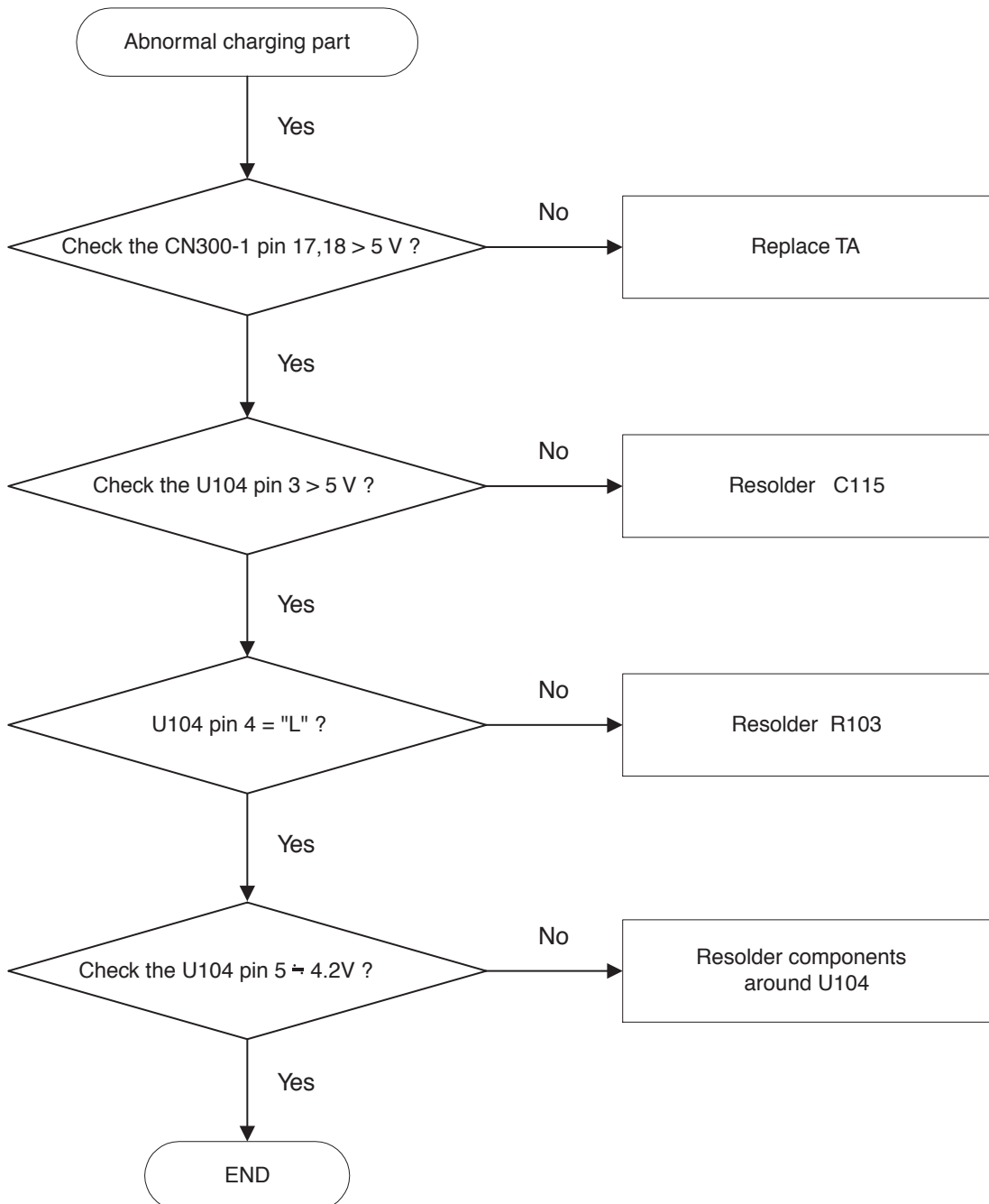

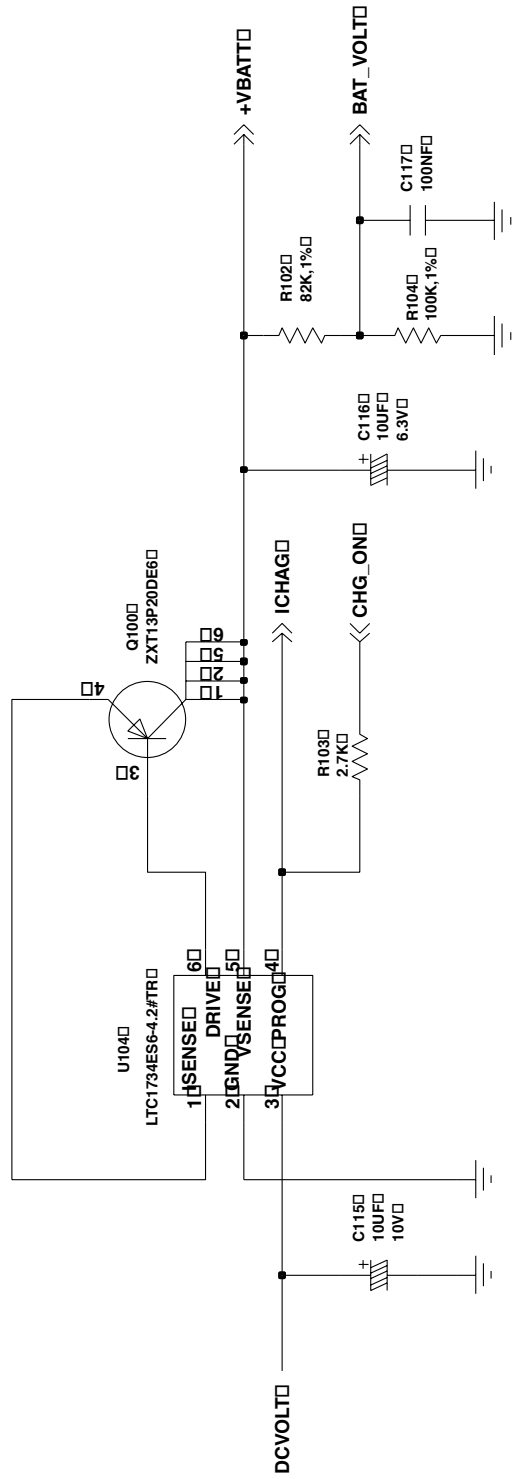

5-4 Sim Part

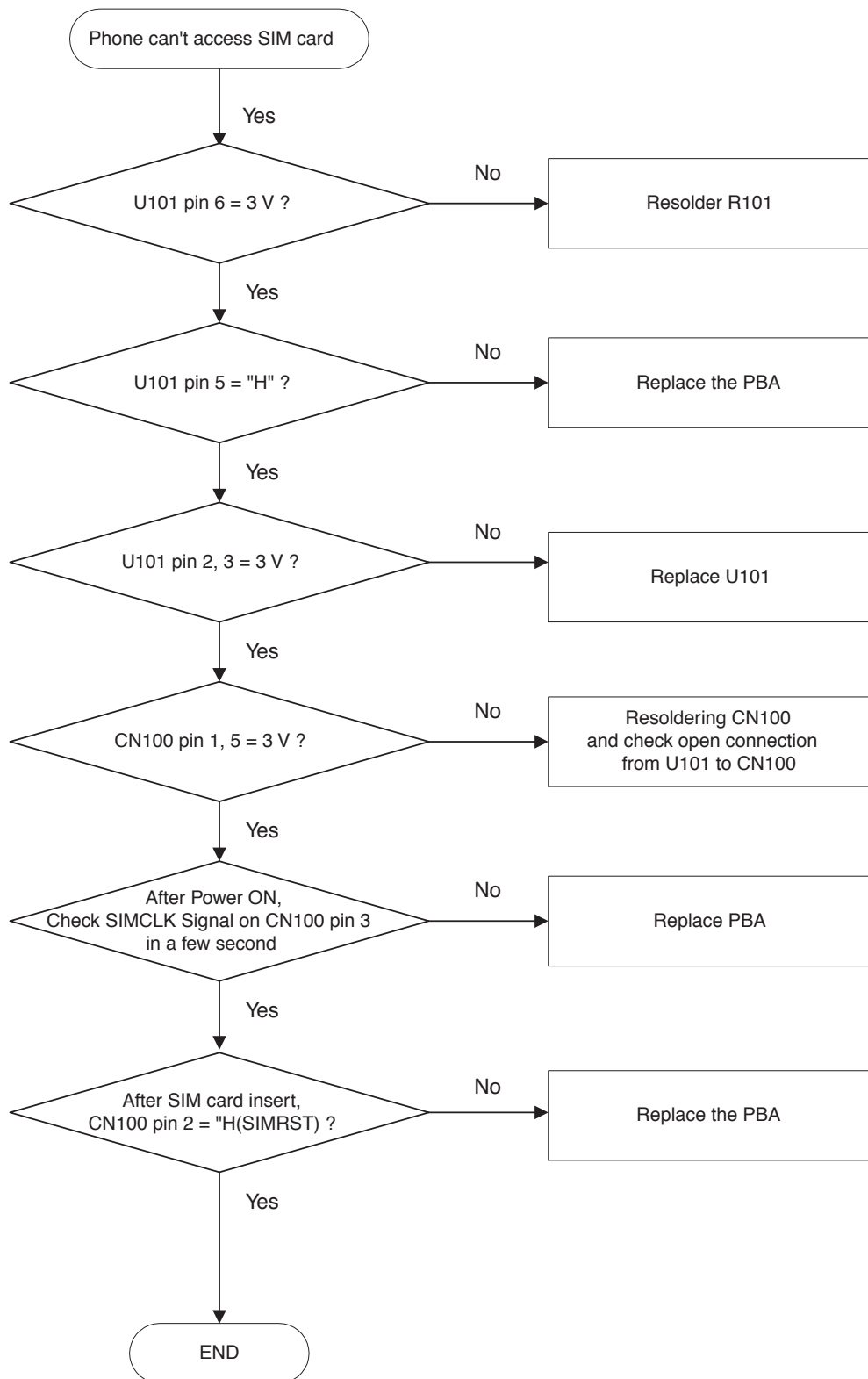

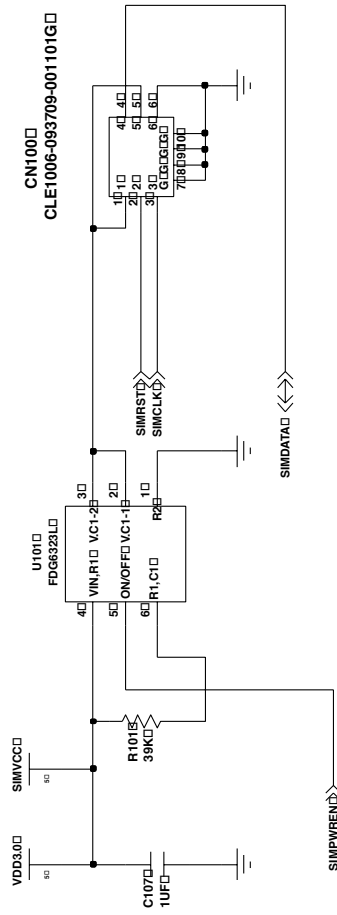

5-5 Microphone Part

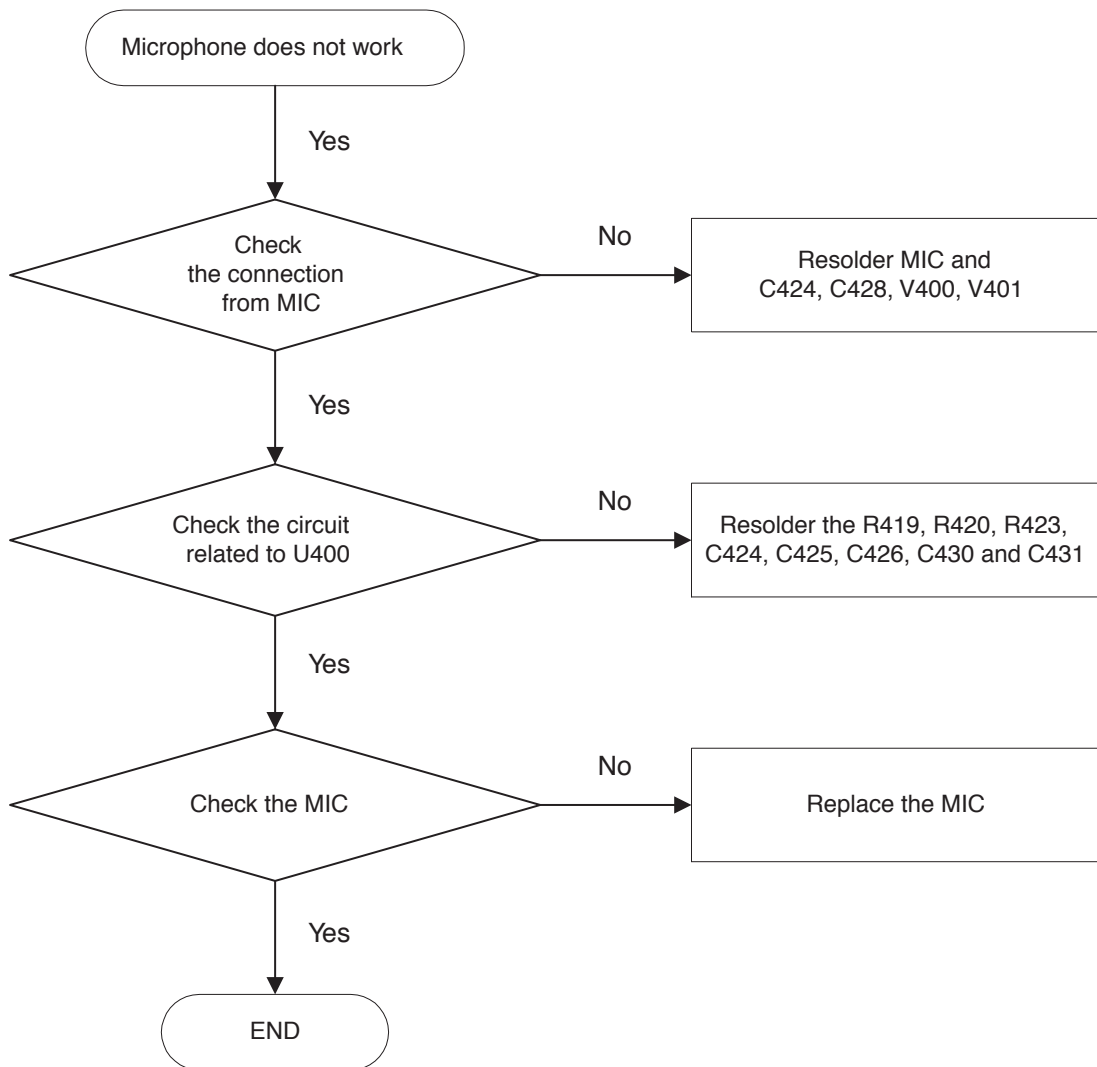

U400

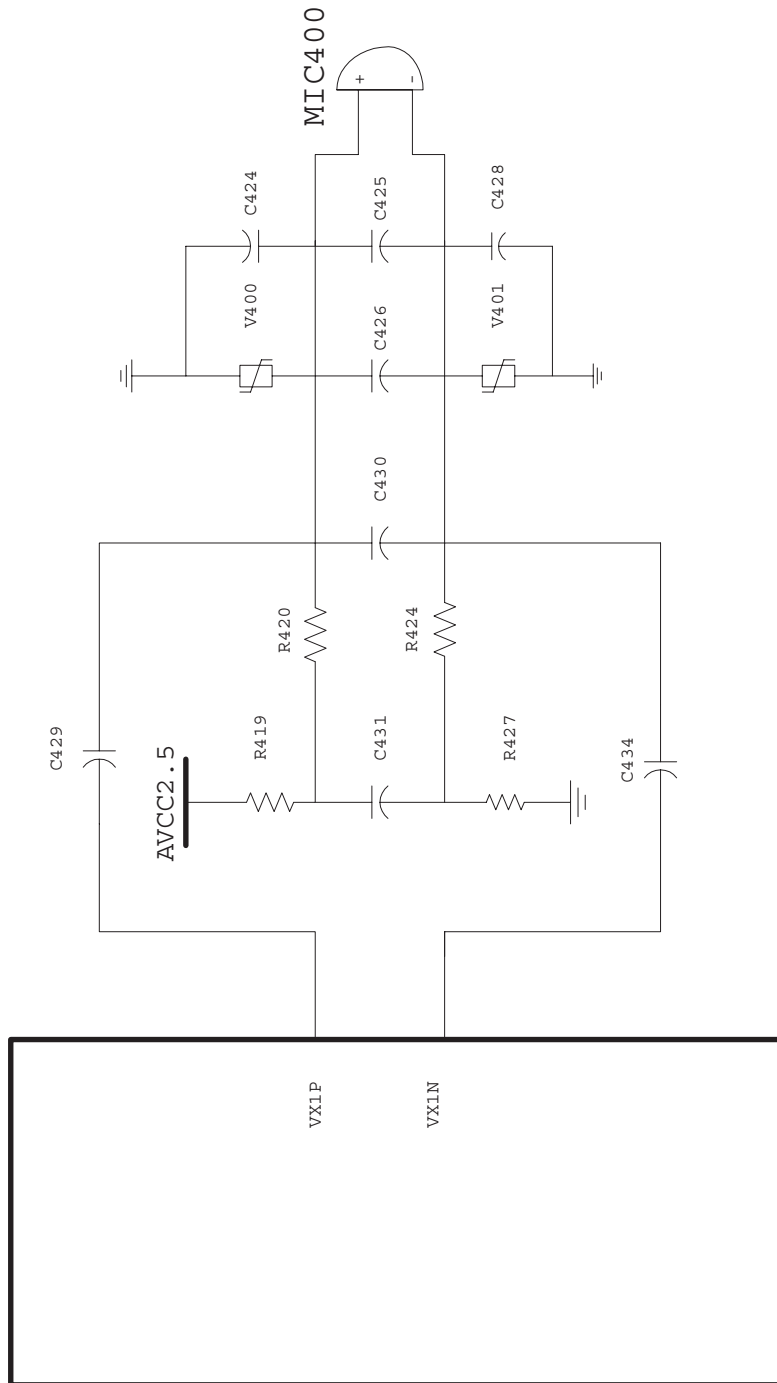

5-6 Speaker Part

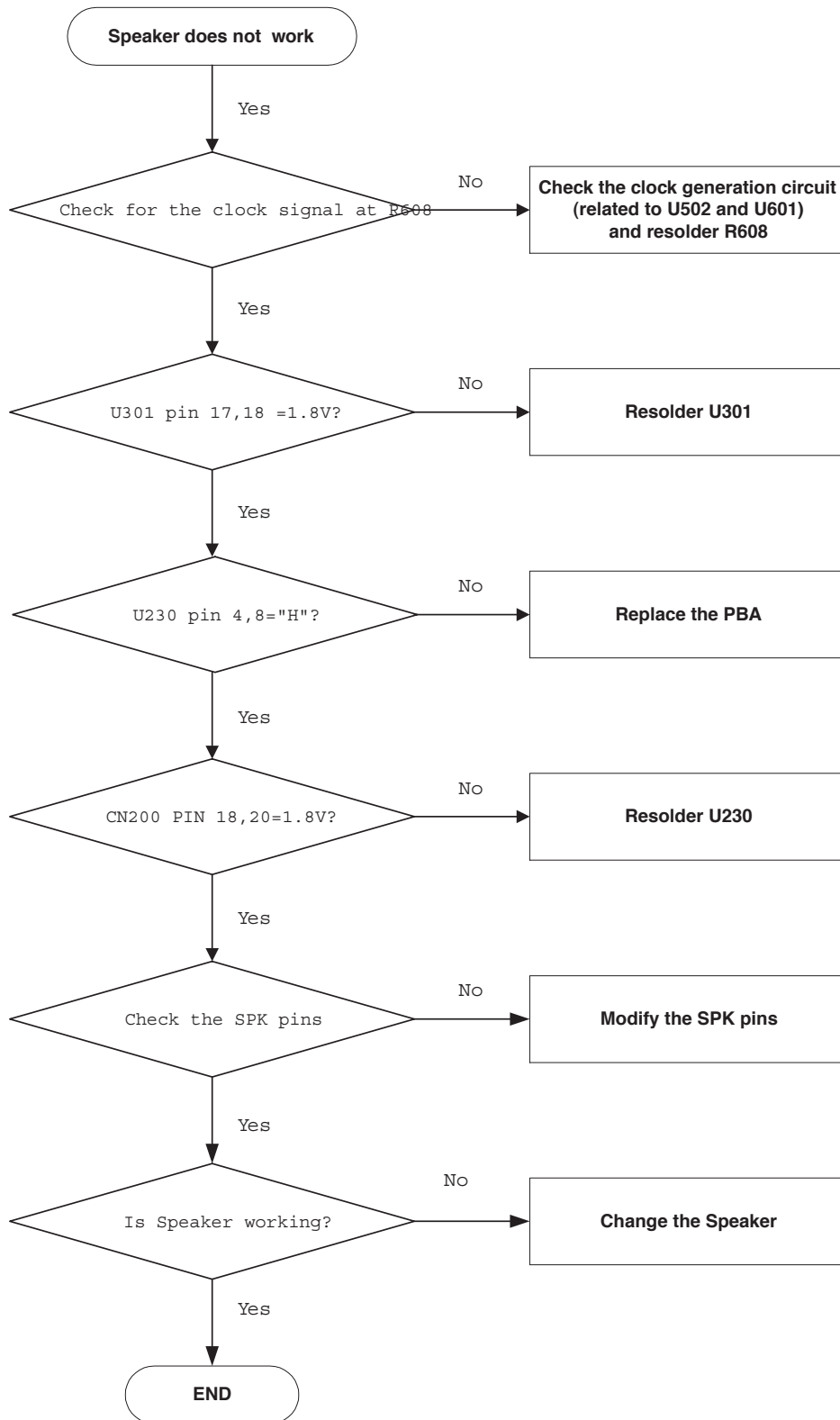

5-7 Key Data Input

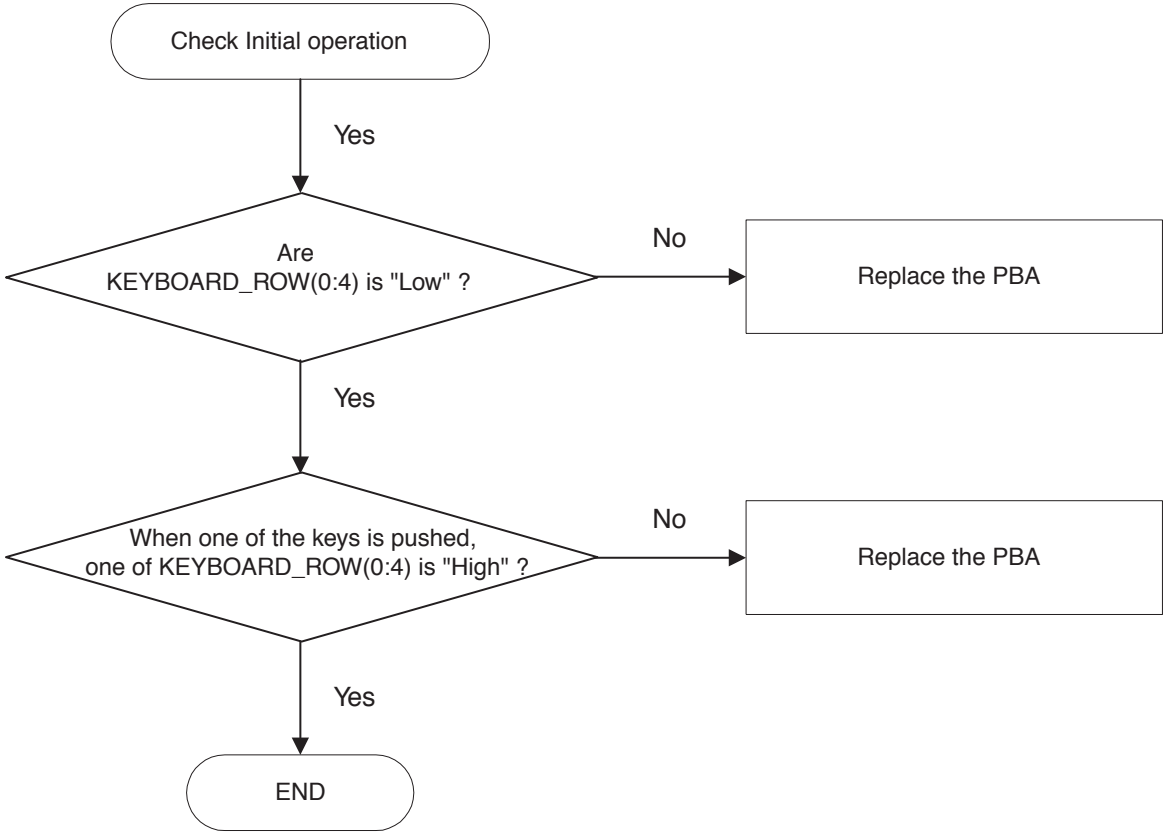

5-8 Receiver Part

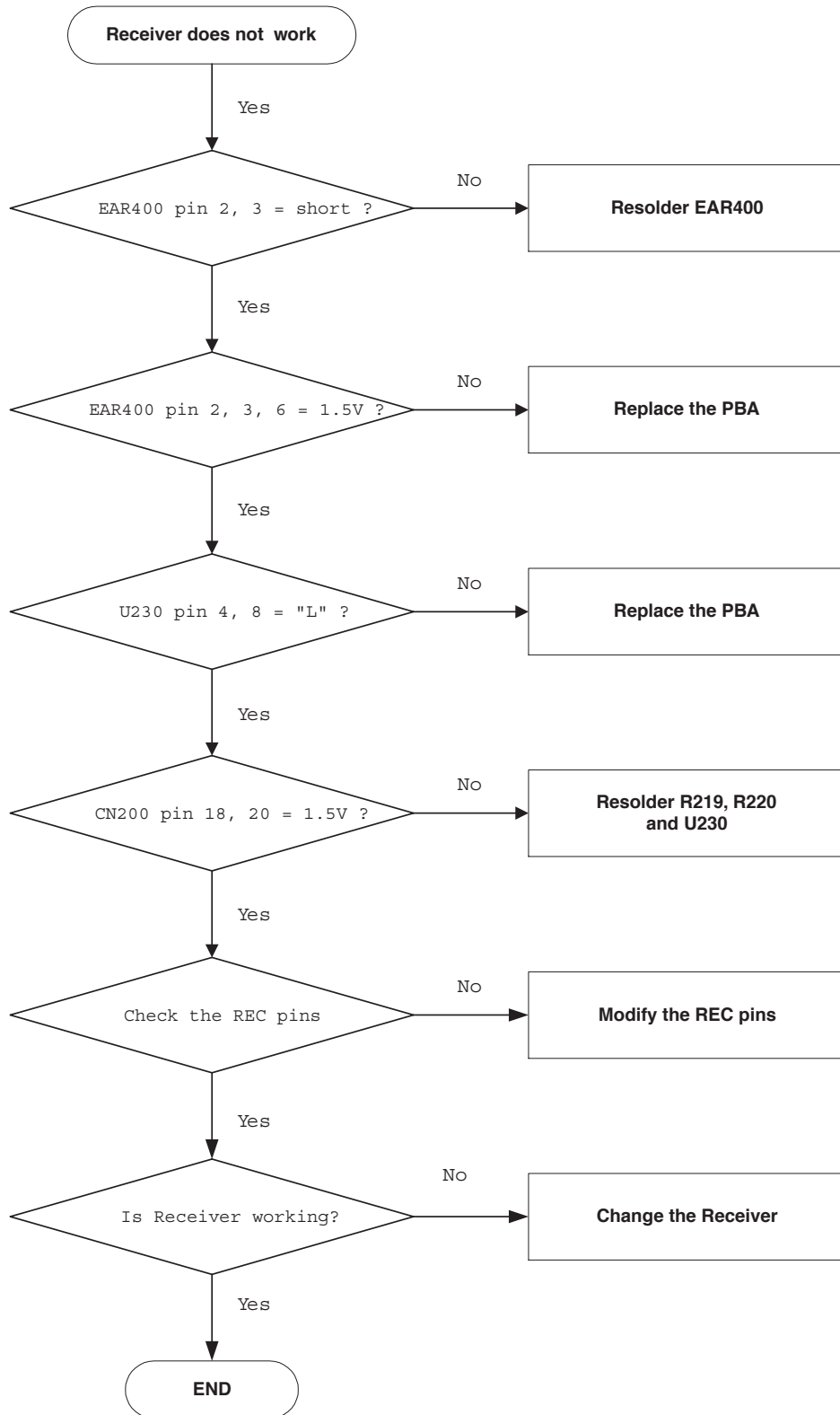

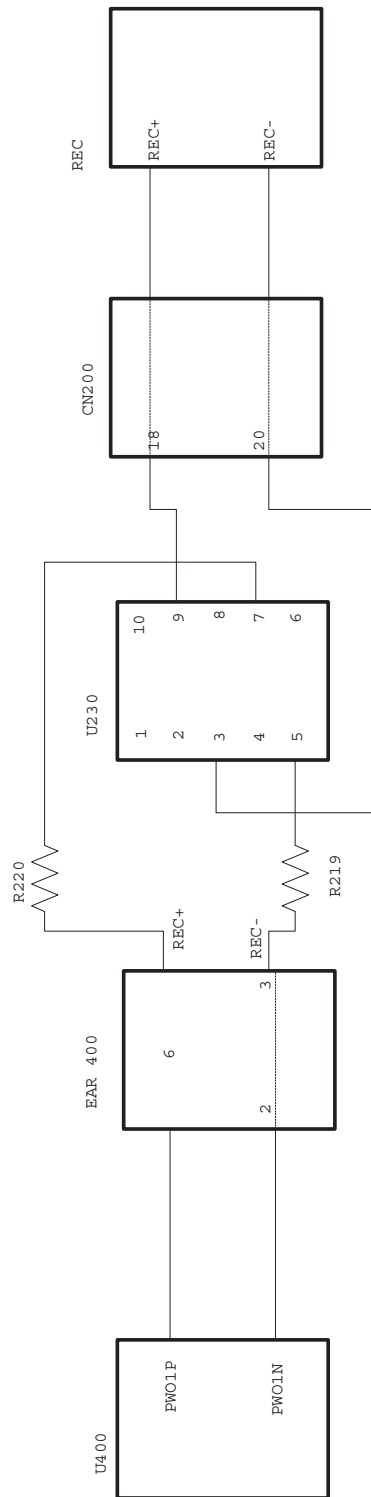

5-9 Ring Indicator

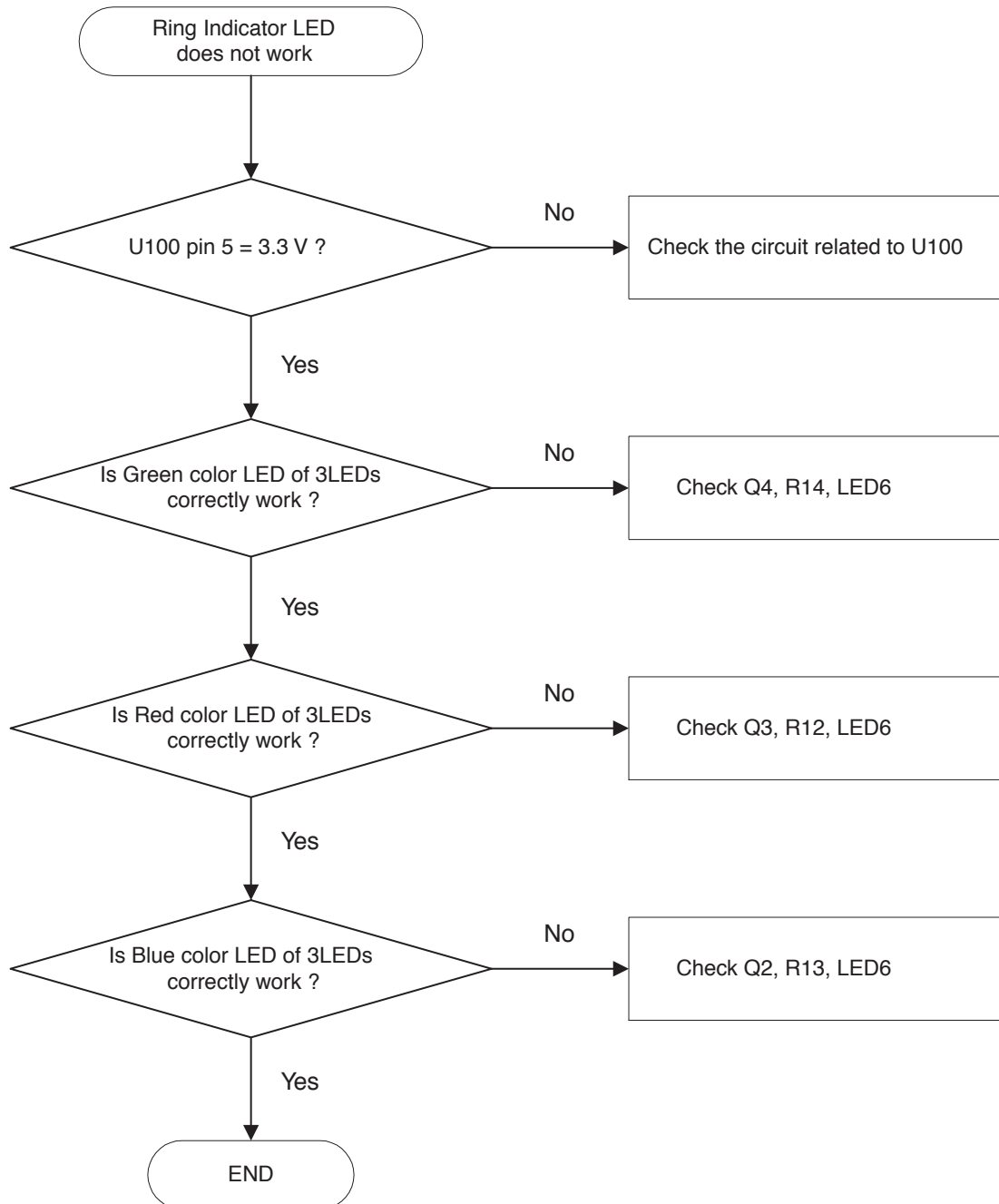

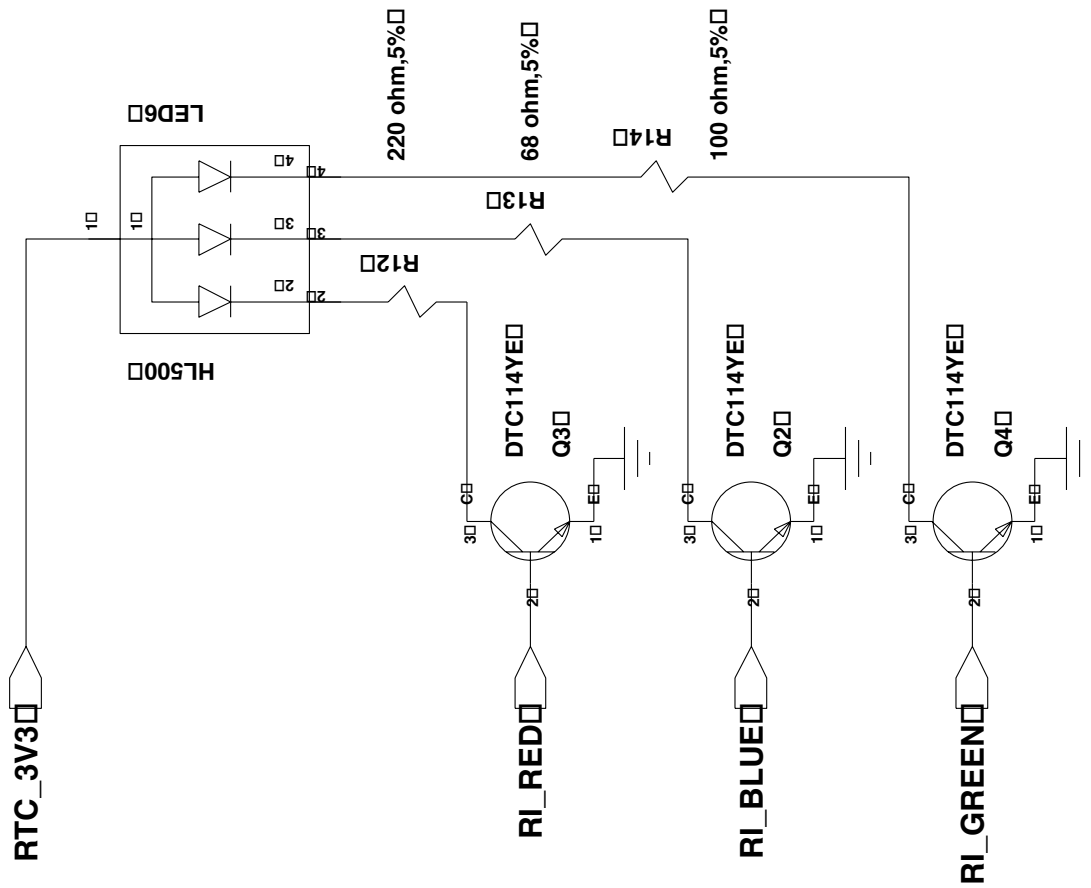

5-10 Back Light (for Main & Sub LCD)

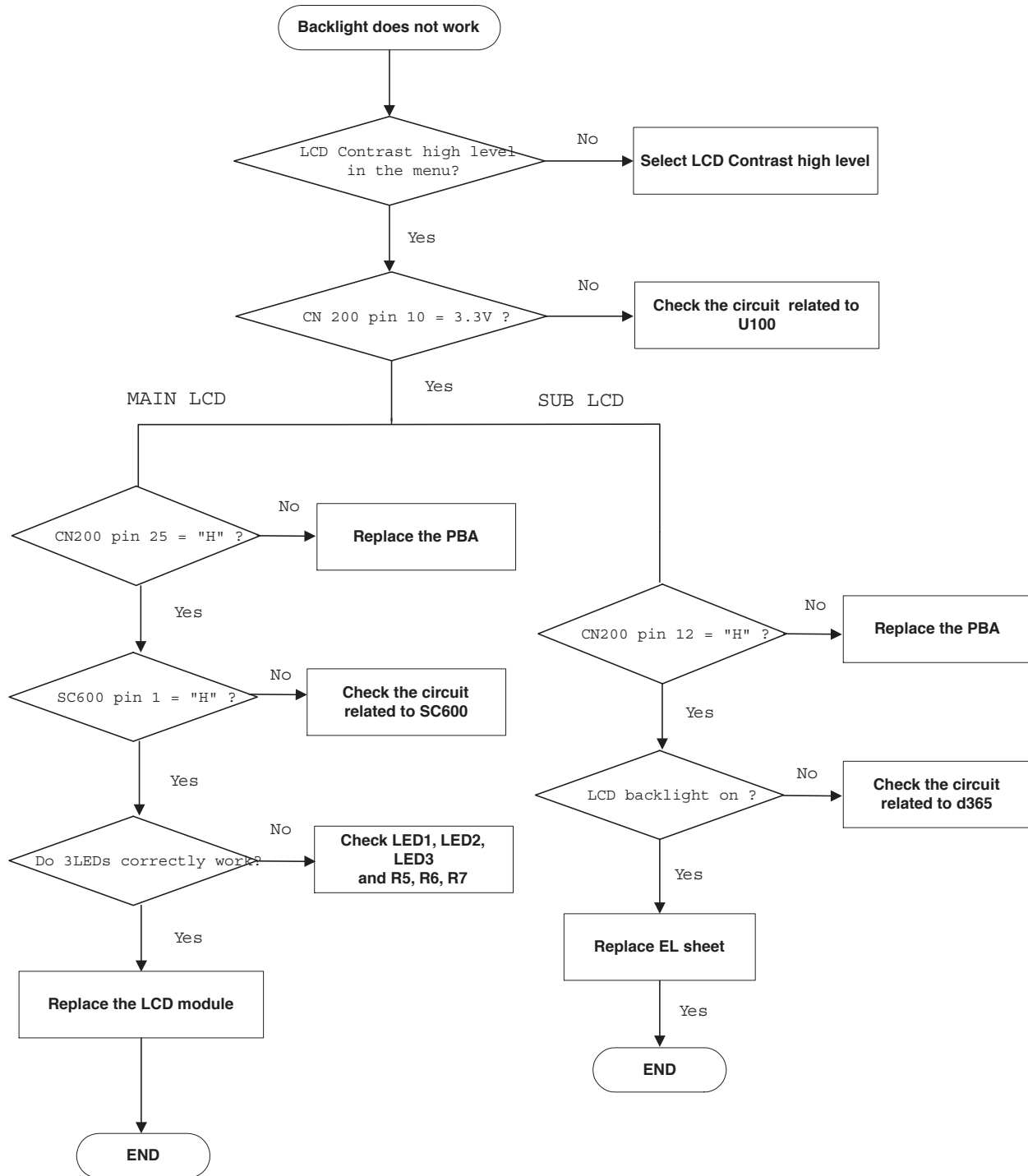

5-11 Back Light (for Key)

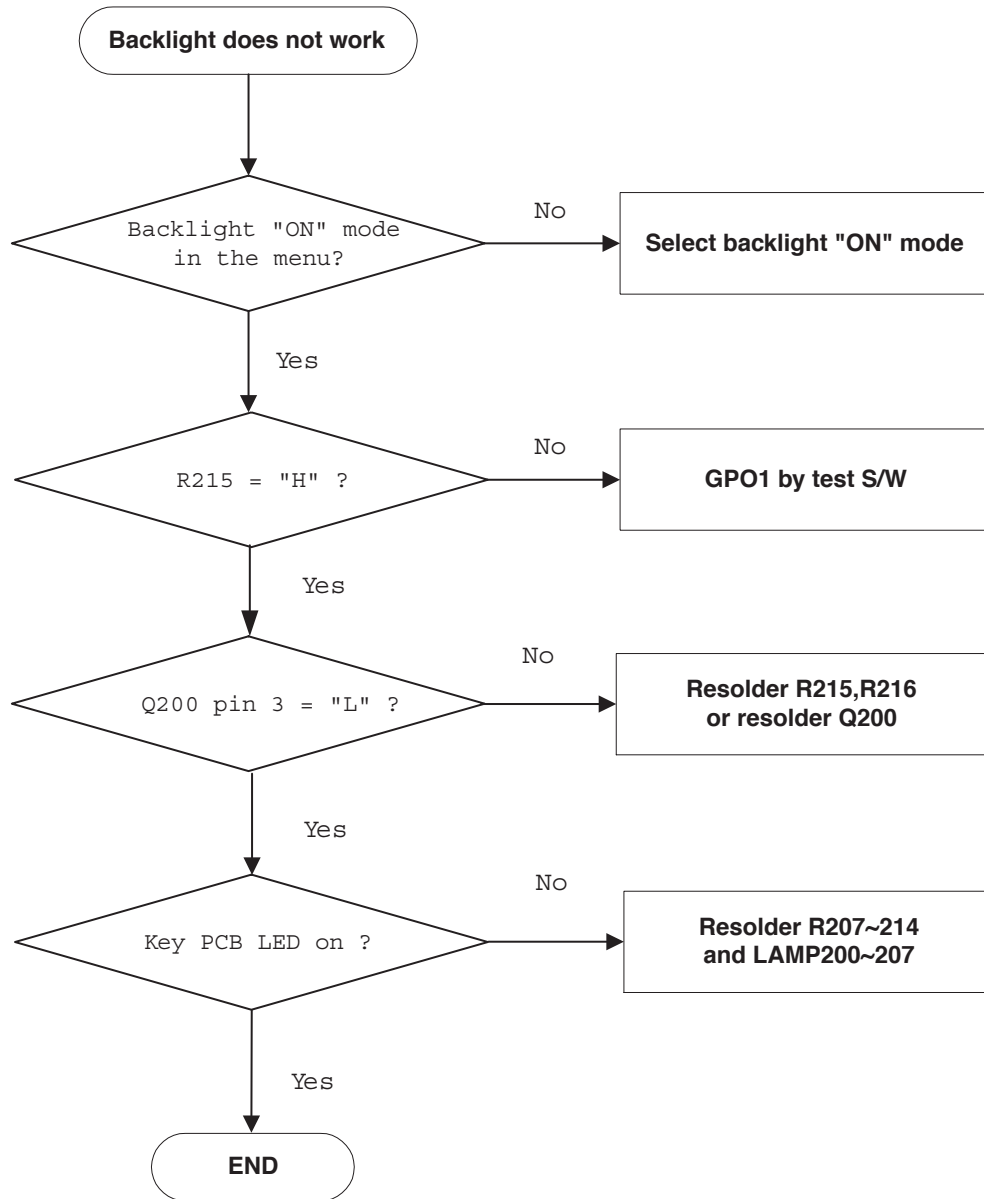

5-12 GSM Receiver

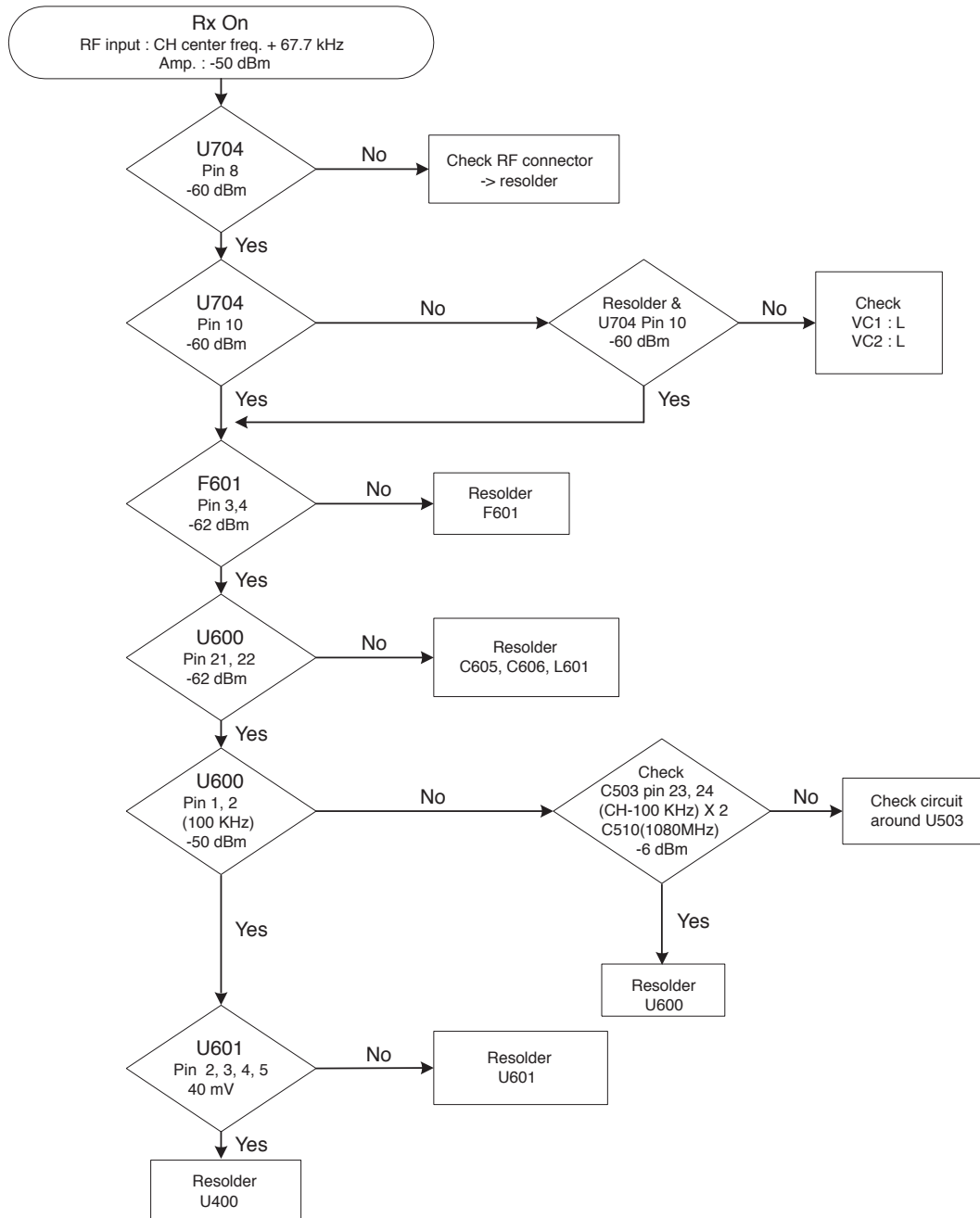

5-13 GSM Transmit

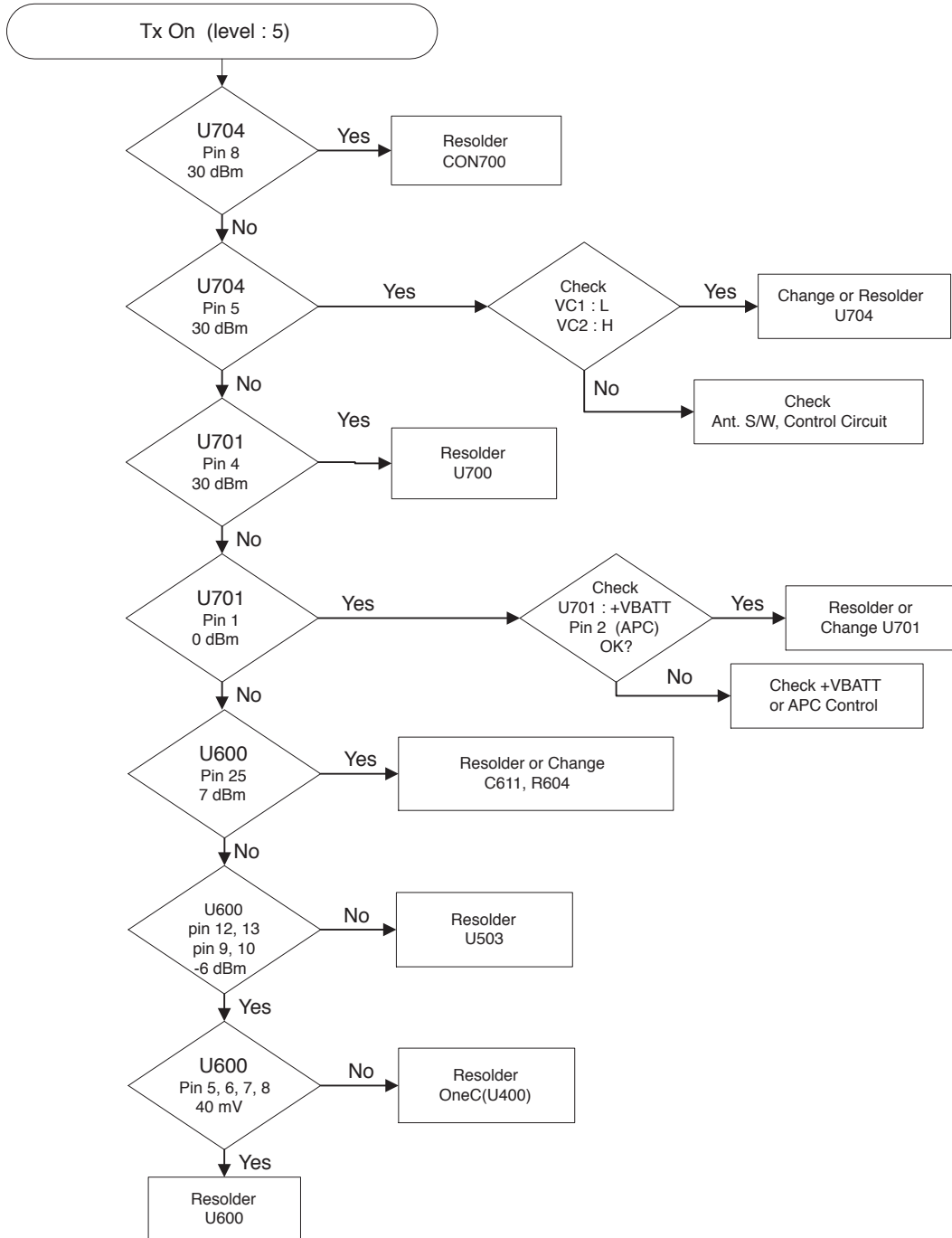

5-14 DCS Receiver

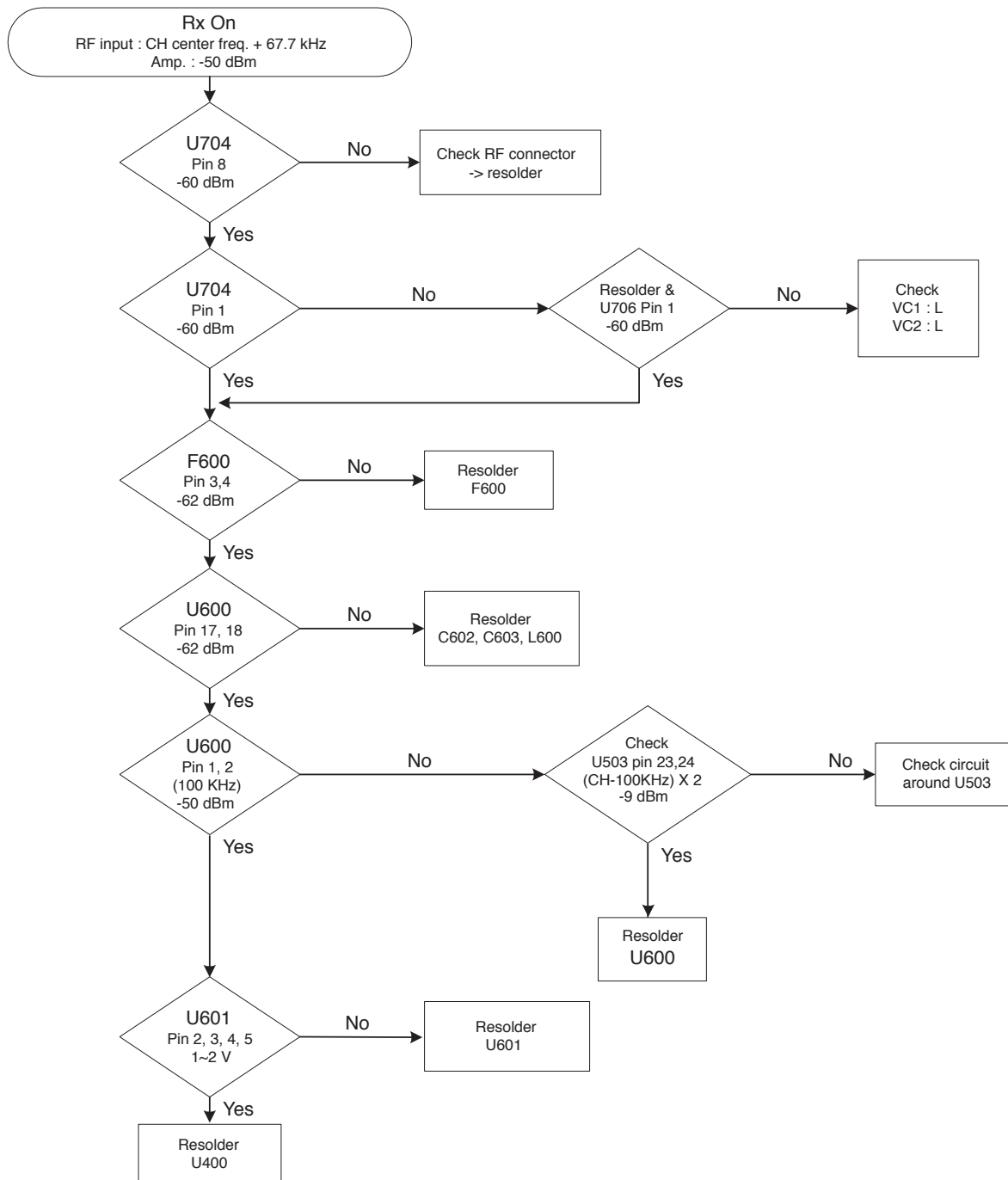

5-15 DCS Transmit

