

## Contents

<b>Getting Started .....</b>	<b>3</b>	<b>Security for Your Phone and</b>	
<b>Making and Receiving Calls .....</b>	<b>9</b>	<b>Subscription .....</b>	<b>52</b>
<b>Key Functions .....</b>	<b>13</b>	<b>Using Two Voice Lines .....</b>	<b>56</b>
<b>Using the Menus .....</b>	<b>14</b>	<b>Calling Card Calls .....</b>	<b>56</b>
<b>Entering Letters .....</b>	<b>18</b>	<b>Setting Network Preferences .....</b>	<b>58</b>
<b>Your Personal Phone Book .....</b>	<b>19</b>	<b>Fax and Data Calls .....</b>	<b>59</b>

### **Ericsson T20s**

First edition (April 2000)

This manual is published by Ericsson Mobile Communications AB, without any warranty. Improvements and changes to this manual necessitated by typographical errors, inaccuracies of current information, or improvements to programs and/or equipment, may be made by Ericsson Mobile Communications AB at any time and without notice. Such changes will, however, be incorporated into new editions of this manual.

All rights reserved.

©Ericsson Mobile Communications AB, 2000

### **Please note:**

Some of the services in this manual are not supported by all networks. *This also applies to the GSM International Emergency Number 112.*

Please contact your network operator or service provider if you are in doubt whether you can use a particular service or not.

**Note!** You should read the “Guidelines for Safe and

## Getting Started

### Front

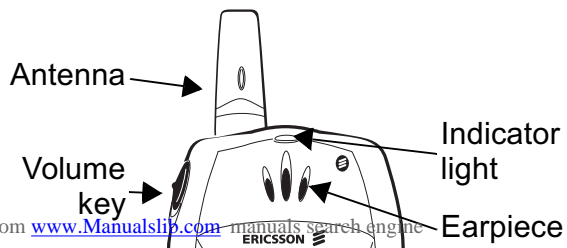

### Back

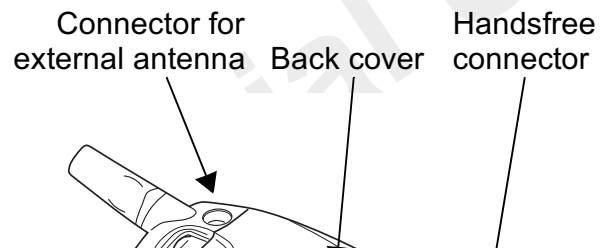

### About this User's Guide

Some services and functions described in this User's Guide are dependent on your network and subscription. Because of this, all menus may not be available in your phone and the shortcut numbers to menus and functions may vary between phones.

This symbol indicates that a service or function is dependent on your network and subscription.



Please refer to the information provided by your network operator for more information about your

the smaller card. Many credit-card-sized SIM cards have a perforated smaller card that you can take out easily.

### Assembly

Before you can use your phone you need to:

- insert the SIM card.
- attach and charge the battery until the indicator light turns green.

**Note:** Always turn off the phone and detach the

## Inserting and Removing the SIM Card

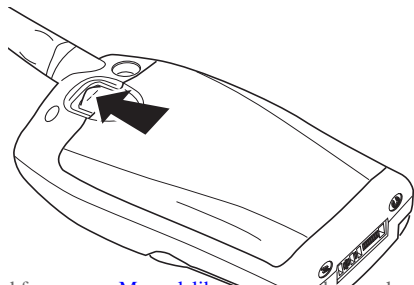

1. Remove the back cover by sliding the release catch upwards. Then lift the cover.

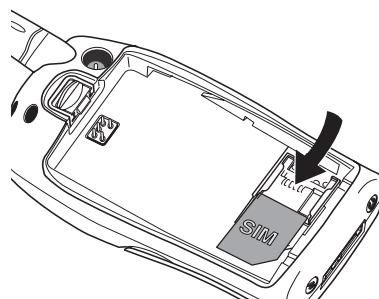

3. To remove it, raise the edge of the SIM card and slide it out.

### Attaching the Battery to Your Phone

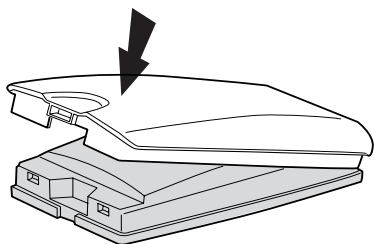

1. Remove the back cover of the phone. Press it onto the battery until you hear a click. This unit is now referred to

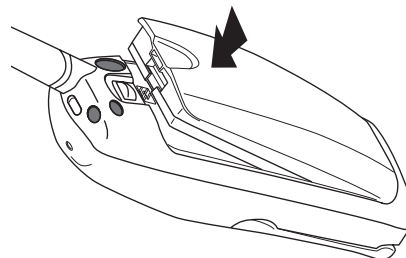

3. Press the battery against the phone until it snaps into place.

## The Battery

Your phone comes with a Li-ion lithium battery. The battery is not charged when you buy your phone, but there may be enough power to switch the phone on. We recommend that you charge the battery until the indicator on top of the phone shows a green light and then for another half-hour before you use the phone for the first time. Charging the battery fully, lengthens its lifetime.

## Charging the Battery

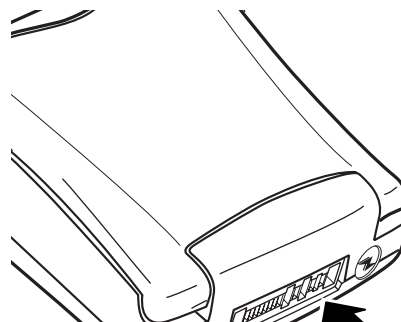

- To indicate charging:
- the battery meter in the display pulses continuously
  - if the phone is on, the indicator on top of the phone shows a steady green light.

**Note:** *If you charge a new battery, or one that has not been used for a long time, it may take a while before you get an indication of charging in the display.*

You can use the phone while the battery is being charged. However, this lengthens the charging time.

### Attaching the Strap

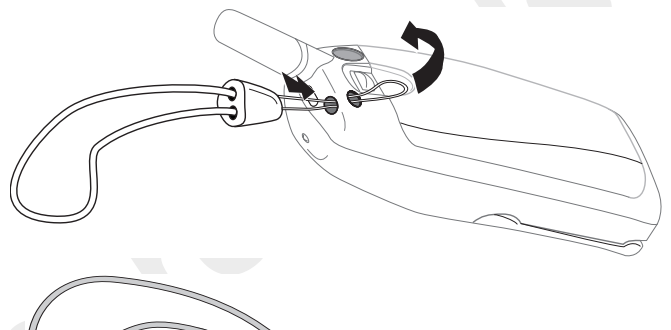



## Making and Receiving Calls

Before you can make and receive calls, you need to turn on the phone and be within range of a network.

### Turning Your Phone On

1. Open the flip.
2. Press and hold the **NO** key until you hear a tone.

Some SIM cards are protected with a PIN (Personal Identity Number).



indicator light on top of the phone flashes green and your network operator's name appears in the display.

This is called "standby mode".

You can now make and receive calls.

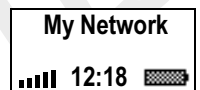

**Note:** *If you do not reach standby, see "Error Messages" on page 66.*

### Making a Call

1. Open the flip.

### Turning Off the Microphone

During a call you can turn off the microphone.

- Press the **c** key for a few seconds to turn off the microphone.
- Press and hold **c** again to resume the conversation.

### Turning Your Phone Off

- In standby mode, press and hold the **no** key until the shut down show starts, or until the phone switches off. To go to standby mode, press and hold **no**.

### Automatic Re-Dialling

If a connection failed, and the display shows *Retry?*, you can re-dial the number by pressing the **YES** key.

Your phone automatically re-dials (up to 10 times):

- until the call is answered, or
- until you press a key or receive a call.

**Note:** *Automatic re-dialling is not available for fax and data calls.*

### Making International Calls

country, with or without a SIM card inserted, if a GSM network is within range.

**Note:** *Some network operators may require that a SIM card is inserted, and in some cases that the PIN has been entered as well.*

### Emergency Numbers

Some countries may not promote the international emergency number, 112. Your operator may therefore have stored additional local



If your subscription includes the Calling Line Identification (CLI) service and the caller's network sends the number, the caller's number is shown in the display. If you have saved the caller's name and number in the phone book, the caller's name is displayed. If the network does not send the number, the display shows *Withheld*.

### Answering a Call

- Open the flip, or press **YES** if the flip is open.

### **The Notepad**

If you want to make a note of a phone number during a call, you can use your phone display as a notepad.

Use the number keys to enter the number. When you end the call, the number remains in the display.

When you enter the number, the person at the other end can hear the tones. You can turn the tones off (can only be done during a call).

#### *To turn the tone signals off during a call*

1. Press  until the *Ongoing Call* menu appears.

5. Press **YES** to select *Next Call*.

6. Select *Hide My Number* or *Show MyNumber* and press **YES** to make the call.

### **Ciphering**

Ciphering is a built-in feature that scrambles your calls and messages to provide additional privacy.

An exclamation mark inside a triangle is shown in the display during a call to indicate that ciphering is currently not being provided by the network.

## Key Functions



The table below shows some examples of the key functions. See also “Quick Keys” on page 69.

Key	Use
Flip	Open the flip to answer incoming calls. (To end a call, close the flip.)
YES	To make calls and answer calls. To select a menu or setting.

Key	Use
1–9, 0	To enter the digits 0–9. Press and hold 0 to enter the international prefix +. To enter letters. To move through menus using shortcuts.
*	To enter *. To shift between capital and lower-case letters when entering text.
# (Hash)	To enter #.

## Using the Menus



There are seven main menus. Each menu has several sub-menus, where you find the different functions.

You move through the menus by pressing the  and  keys, or by using shortcuts. You move from left to right in the main menus and up and down in the sub-menus.

### Moving Through the Menus

There are two ways of moving through the menus:

### Using Shortcuts

A quicker way to move through the menu is to use shortcuts. Enter the menus by pressing  or  and then simply enter the number of the menu to which you want to go. To get back to standby, press and hold **no**.

### How to Interpret the Instructions

In this example of how to interpret the instructions, we are going to set the key sound to the tone option.

2. Press **YES** to select the *Settings* menu. The name of the menu that you have chosen is shown at the top of the display (*Settings*).

A flashing arrow in the right part of the display indicates that more menus are available.

3. Press **YES** to select the *Sounds & Alerts* sub-menu. (You do not



### Shortcuts

This is how to interpret the instructions above by using shortcuts:

#### *To set the key sound*

1. Press **4** or **9** to enter the main menu.
2. Press **4** to select the Settings menu.
3. Press **1** to select the Sounds & Alerts sub-menu.
4. Press **9** to select the Key Sound sub-menu.
5. Press **4** or **9** to scroll to Tone.
6. Press **YES** to select the tone option.

- Grey text indicates a function that is temporarily unavailable, for example due to your subscription or due to a certain setting which has not been turned on.



- A filled button indicates that this option is selected.



- A tick indicates that this item is selected.



SIM card, *Automatic*. If this is not the case, the preset language is English.

*To change the display language*

1. Scroll to *Settings*, **YES**, *Language*, **YES**, *Menus*, **YES**.
2. Select a language and press **YES**.

**Note:** You can always choose *Automatic* by pressing 8888 in standby.

You can always choose *English* by pressing 0000 in standby.



## Menu Overview

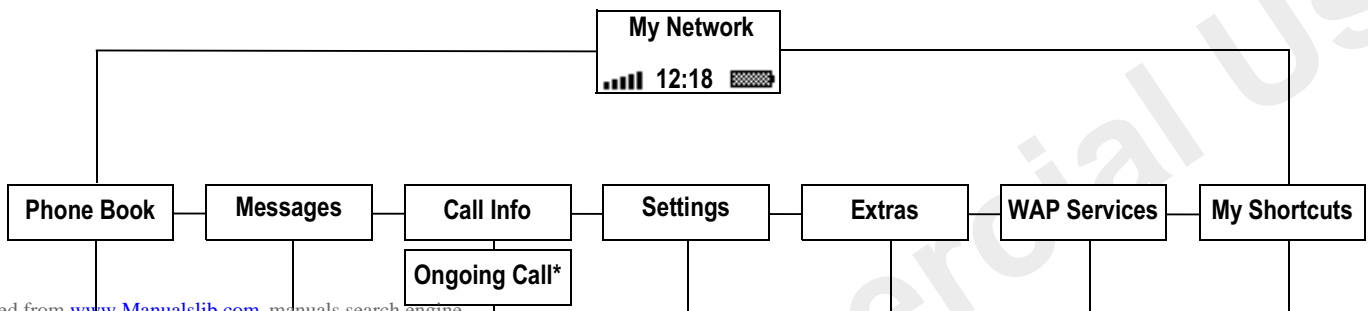

## Entering Letters

You can enter letters when you add names to the phone book, write text messages (SMS) or enter WAP addresses. Press the appropriate key, **1–9, 0** or **#**, repeatedly until the character you want appears in the display.

**Press... to get...**

1 Space - ? ! , . : ; " ' < = > ( ) \_ 1

Example:

- To enter an 'A', press **2** once.
- To enter a 'B', quickly press **2** twice.
- To enter lower-case letters, enter the letter, for example an 'A' and then press **\***. Lower-case letters appear until you press **\*** again.
- To enter numbers, press and hold any numeric key.
- To delete letters and numbers, press **c**.

## Choosing Alphabet(s)

You can choose which alphabet(s) (input methods)

## Your Personal Phone Book



Your phone has a phone book in which you can save numbers and accompanying names (an entry).

This means that you can recall a number from the phone book instead of entering the number again.

Your phone also supports voice dialling which means that you can add a voice label to a phone book entry and then call that entry by simply saying the name. See “Voice Control” on page 45.

*To save a number together with a name*

1. Scroll to *Phone Book*, **YES**, *Add Number*, **YES**.
2. Select *Add new?* or any of the numbers from the list by pressing **YES**.
3. Enter the phone number that you want to save and press **YES**.
4. Enter a name that you want to associate with the phone number and press **YES**.  
See “Entering Letters” on page 18.
5. Press **YES** again to save the entry in the suggested position.

2. Enter the name (or the first few letters of the name) associated with the number that you want to call and press **YES**.  
If the name displayed is not the one you want, press  or  until you find the correct name and number.
3. Press **YES** to make the call.

### Shortcuts to Phone Book Entries

You can call the phone numbers that you have saved in positions 1-9 by entering the position number in

so on. When you find the entry you want, press **YES** to make the call.

### Ask to Save

If Ask to Save is on, you are asked if you want to save any called or answered number that is not already saved in your phone book.

*To turn the Ask to Save function on or off*

1. Scroll to *Phone Book*, **YES**, *Options*, **YES**, *Ask to Save*, **YES**.

3. Press **YES** to select the entry.
4. Select *Edit* and press **YES**.
5. When you have finished editing, press **YES** to save your changes.

#### *To delete an entry from the phone book*

1. Scroll to *Phone book*, **YES**, *Find and Edit*, **YES**.
2. Enter the name (or the first few letters) for the entry that you wish to edit and press **YES**.
3. When the entry you want to delete is highlighted, press **C**.

#### Phone Book Memories

Your phone book entries are saved in the memory on your SIM card. The number of entries you can save depends on your SIM card. By saving your entries on the SIM card, you still have access to them if you use the card with another phone.

You can also save your entries in the phone memory. The phone memory holds 100 positions in which your entries are saved when all SIM positions are occupied. If you save your entries in the phone memory, you still have access to them if you use another SIM card

on your SIM card, you can enter position number 201 to save a number in the first position of the phone memory.

### **Overwrite Protection**

If you try to save a phone number in a position which already contains a phone number, the message *Overwrite?* appears together with the name saved in that position. You now have two options:

- Press **YES** to replace the number with the new one.
- Press **NO** if you do not want to replace the old number.

*To delete all entries from the phone memory*

1. Scroll to *Phone Book*, **YES**, *Options*, **YES**, *Delete All*, **YES**.
2. Press **YES** again.
3. Enter the phone lock code (*0000* or another one that you have chosen yourself, see “The Phone Lock” on page 52), and press **YES**.

**Note:** *The entries on your SIM card are not deleted.*

### **Groups**

### *To add a member to an existing group*

- Select the group you want and then select *Edit/Add new?*. Select a new member and then press **YES**.

### **Copying From One SIM Card to Another**

You can copy your phone book entries on one SIM card to another, via the phone's memory.

If your phone memory contains phone book entries that you wish to keep, you first need to copy these entries from the phone memory to a SIM card, otherwise they will be deleted.

3. Enter from which position number on the SIM card you want to start copying and press **YES**.
4. Press **YES** again to start copying.  
Wait until the display shows *Phone book entries copied:*.

### *To copy from the phone memory to a SIM card*

1. Insert a SIM card.
2. Scroll to *Phone Book*, **YES**, *Options*, **YES**, *Copy*, **YES**, *Copy to card*, **YES**.
3. Enter the position number of your SIM card where

## Using the Call List

The Call List is a phone number log that saves information (time, date, phone number and name) about the last 20 dialled, answered and missed calls. Once your list exceeds 20 calls, the oldest one is deleted.

The calls are saved in chronological order, except for the last dialled number, which is always displayed in the first position. If you check a call within 24 hours, the time of the call is displayed. Otherwise, the time

*To turn the call list on or off*

1. Scroll to *Call Info*, **YES**, *Options*, **YES**, *Set Call List*, **YES**.
2. Select *On* or *Off* and press **YES**.  
If you turn off the list, it is cleared.

### Missed Calls

If you have missed a call, the message *Missed Calls: 1* appears in standby mode. (The number indicates the number of missed calls.)



## Your Voice Mail Service

The answering service of your network operator allows callers to leave a voice message when you cannot answer your calls.

Depending on your operator, you are informed that someone has left a message in different ways.

Most operators send a text message (SMS), asking you to call your voice mail service, for example. See “Text Messages (SMS)” on page 32 for more information.



### *To call your Voice Mail Service*

- Press and hold **1** from standby.

You can also select Call Voice Mail from the Messages menu.

### **Receiving a Voice Mail**

When you receive a voice mail, your phone beeps and the message *New Voice Mail* appears in the display.

- Press **YES** to listen to the voice mail.

If you want to listen to it later, press **NO**.

## Personalizing Your Phone

You can adjust the phone settings to suit your own requirements.

### Ring Signals

You can specify the ring signal volume, choose among different ring signals or compose your own.

#### Ring Signal Volume

The ring signal volume can be set to six levels. You

*To turn the ring signal on or off*

1. From standby, press and hold **c**.
2. Press **YES**.  
All signals except the alarm and timer signals are turned off.  
To cancel, repeat step 1 and press **YES**.

#### Increasing Ring

You can choose a ring signal that rises in steps from the lowest volume to the highest.

**Tip:** Use the volume key on the side of the phone to scroll silently.

**Tip:** If you subscribe to the “Two Line Service”, you can set different ring signals for the two lines. If your SIM subscription supports fax and data calls, you can set different ring signals for these too.

#### Specific Ring Signals for Personal Calls

If your subscription includes the Calling Line Identification (CLI) service, you can assign a

2. Enter the caller’s number and press **YES**.  
Press  to recall a number from the phone book.
3. Select a ring signal and press **YES**.

#### Composing Your Own Ring Signal

You can compose four different ring signals.

#### To compose or edit a ring signal

1. Scroll to *Settings*, **YES**, *Sounds & Alerts*, **YES**, *My Melodies*, **YES**.
2. Select one of the melodies and press **YES**.

### **Vibrating Alert**

You can choose to be notified of an incoming call by the buzzing of the Vibrating Alert. You can set the phone's Vibrating Alert to one of the following:

- **On** (all the time)
- **On If Silent** (on when the ring volume is turned off or when you have set the phone to silent)
- **Off** (all the time)

**Note:** *When your phone is placed in a desktop charger or a handsfree car kit, the Vibrating Alert is turned*

### **Key Sound**

You can set the key sound to clicks, tones or silent.

- Select *Key Sound* from the *Settings/Sounds & Alerts* menu and then select the key sound you want.

### **Minute Minder**

If you turn on the minute minder, you hear a beep once every minute during a call.

- Select *Minute Minder* from the *Call Info/Call Timers* menu and then select *On* or *Off*.

### To add a function to My Shortcuts

1. Scroll to *My Shortcuts*, **YES**, *Edit Shortcuts*, **YES**.
2. Select a function from the list by pressing **\***.
3. Enter the position number you want for your function in this menu and press **YES**.  
To add another function, repeat steps 2 and 3.  
To remove a function, repeat steps 1 and 2.
4. Press **YES** to exit the list.

**Tip:** Press and hold  to reach the first sub-menu in the menu *My Shortcuts*.

You can choose a 12-hour or a 24-hour clock.

- Select *Time Format* from the *Settings/Time and Date* menu, then select the time format you want.

### Automatic Time Zone

If you turn on the *Automatic Time Zone* function, you will be asked if you want to set the clock when you enter a new time zone.

- Select *Automatic Time Zone* from the *Settings/Time and Date* menu.



### Internet Time

Swatch® Internet time represents a new global time concept, without time zones. The time is the same all over the world.

The 24 hours of the day are divided into 1,000 “beats”. 1 beat is 1 minute 26.4 seconds. Internet time is identified by @ plus three digits, ranging from @000 to @999. The Internet Day starts at midnight (wintertime) in Bienne, Switzerland, the home of Swatch. Internet Time was invented by Swatch Ltd.

When Internet time is on, it is displayed in standby mode instead of local time. You can still view local time when Internet time is on by pressing the **NO** key once. If you turn Internet time off again, you can still view it in standby by pressing the **NO** key once.

When Internet time is on, you can convert Internet time to local time and vice versa.

#### *To convert from Internet time*

1. Scroll to *Extras*, **YES**, *Convert Time*, **YES**, *From I-net time*. **YES**.

### *To select answering mode*

1. Scroll to *Settings*, **YES**, *Handsfree*, **YES**, *Answering Mode*, **YES**.
2. Select an answering mode and press **YES**.

**Tip:** *You can also answer a call by using the voice answering function. See "Voice Answering" on page 46.*

### **Start Up/Shut Down Show**

When you turn your phone on or off, the Ericsson

2. Select a show and press **YES**.
3. Select *Animationsound*, **YES**, *On* or *Off*, **YES**.

### **My Animation**

By purchasing the Ericsson infrared modem, DI 28, you can create and download your own start up show (provided you have a PC). You can also compose or download a melody and set this as your start up melody. From your phone, you can set the transition of your animation, for example if you want it to "box out" etc.

- Select *My Animation* from the *Settings/Display/User*

### Master Reset

You can reset the phone settings to the way they were when you bought your phone.

#### *To reset the phone*

1. Scroll to *Settings*, **YES**, *Master Reset*, **YES**.
2. Enter the phone lock code (0000 or the new code if you have changed it) and press **YES**.

### Text Messages (SMS)

You can use the Short Message Service (SMS) to send and receive text messages consisting of up to 160 characters.



If the number to your service centre is not stored on your SIM card, you must specify the number yourself. Otherwise you cannot reply to received messages or send your own.

*To check the number to your service centre*



3. Enter the recipient's phone number or recall it from the phone book by pressing .
4. Press **YES** to send the message.

If you want to send the message later, press **NO** when you are asked to enter the phone number. The message is saved in the *Unsent* list in the *Message* menu.

### **Sending a Text Message to a Group**

You can send text messages to group that you have specified and saved in your phone book. see "Groups"

You can set a standard option or turn on "set on send", which means that you make your choices each time you send a message.

### **Message Type**

You can send different types of messages. Your network operator's service centre may offer the facility of converting a text message into a format (e-mail, fax, etc.) that suits the equipment that is going to receive the message.

### *To set a validity period*

1. Scroll to *Messages*, **YES**, *Options*, **YES**, *Validity Period*, **YES**, *Set Default*, **YES**.
2. Select a validity period and press **YES**.  
To turn on the Set on Send option, select *Set on Send*, then *On* and press **YES**.

### **Reply to Messages**

If you want the recipient of your message to reply, you can turn on the Request Reply option.

### *To create a template*

1. Scroll to *Messages*, **YES**, *Templates*, **YES**, *Add new?*, **YES**.
2. Enter the message and press **YES**.
3. To send the template now, press **YES** when *Send message now?* appears and proceed as described in "To send a text message" on page 32.  
Press **NO** if you do not want to send the template now.

To send a template later, select it from the *Template* list in the *Message* menu, and proceed as described in

3. When you have read the message, press **YES**. A new menu with different options appears. These options are described on the following pages.

**Note:** *If the sender of the message wants you to reply, the message "Reply requested Reply?" appears in the display. Press **YES** again to reply. If you do not want to reply, press **NO**.*

**To read the message later**

- Press **NO** to save the message in your *Inbox* in the

2. Select *Forward* and press **YES**.

Continue in the same way as when sending a new text message.

**To call a phone number found in a message**

- When the number is highlighted, press **YES** twice.

**To call the sender of the message**

1. When you have read the message, press **YES**.
2. Select *Call* and press **YES**.

the phone memory is full, the oldest read message is deleted when a new message is received.

If the phone memory becomes full of unread messages, new messages are automatically saved on the SIM card. Messages that are saved on the SIM card remain there until you delete them.

*To save a message on the SIM card*

1. When you have read the message, press **YES**.
2. Select *Save* and press **YES**.

messages. Area Information is another type of text message that is sent to all subscribers in a certain network area.

This information could, for example, be a local traffic report or the phone number of a local taxi company.

*To turn Area Information on or off*

1. Scroll to *Messages*, **YES**, *Options*, **YES**, *Area Info*, **YES**, *Reception*, **YES**.
2. Select *On* or *Off* and press **YES**.

read the message in the same way as you read an ordinary text message. You cannot save area messages. When you have read the message and press **YES** or **NO**, it is deleted.

### Cell Information

The “Cell information channel” is used by some network operators for sending messages to their subscribers within a certain network area.

You read messages on the Cell information channel in the same way as when reading area messages.



## The WAP Browser

Your phone has a WAP browser which lets you connect to the Internet and access with specially designed interactive services and view WAP pages. WAP (Wireless Application Protocol) is a standard specially created for mobile communications devices and gives fast access to information and services on the Internet.

Examples of WAP services you may find are:



correctly set. You need to set your User ID and Gateway address, among other things.

Depending on your network operator, you can receive the access settings you need in different ways.

- When you buy your phone together with a WAP subscription. Your operator has already entered all the WAP settings you need.
- Over the air via SMS. Your operator sends you a text message with the access settings you need. When this happens you will be asked if you want to install the

### **Entering the WAP Settings Manually**

The WAP settings you enter will be associated with one of the WAP profiles. If you want to use more than one WAP profile, you need to specify the settings for each profile. See “Using WAP Profiles” on page 42.

**Note:** *Please refer to the information provided by your operator before you enter your settings.*

### **Choosing Which Access Type to Use When Browsing**

3. Scroll to *Access*, **YES**, *Access Type*, **YES**.
4. Select the Access Type you want and press **YES**.

*To set up a GSM Data Connection*

1. Scroll to *WAP Services*, **YES**, *WAP Settings*, **YES**.
2. Select a *WAP profile* and press **YES**.
3. Scroll to *Access*, **YES**, *Gateway*, **YES**, *User ID*, **YES**.
4. Enter the User ID to your gateway and press **YES**.
5. Select *Password* and press **YES**.
6. Enter the password to your gateway and press **YES**.
7. Select *Data Address* and press **YES**.

After you have entered the IP address, press **NO** to go back one level in the menus. You are now in the access menu. Follow the instruction below:

1. Scroll to *GSM Data*, **YES**, *Phone Number*, **YES**.
2. Enter the phone number you use with your GSM Data connection and press **YES**.
3. Scroll to *User ID* and press **YES**.
4. Enter the User ID for your GSM Data Connection and press **YES**.
5. Scroll to *Password* and press **YES**.

7. Select *SMS Address* and press **YES**.
8. Enter the phone number to your gateway and press **YES**.

After you have entered the SMS address phone number, press **NO** to go back one level in the menus. Now you need to enter the phone number to your service centre.

1. Select *Service Centre* and press **YES**.
2. Enter the phone number to your service centre and press **YES**.

#### *To open a homepage*

1. Scroll to *WAP Services*, **YES**.
2. Select the top menu and press **YES**.

The name of this menu depends on what you have chosen to call it. See “To edit the homepage of a WAP profile” on page 43.

#### *To go to a WAP page by entering the address*

1. Scroll to *WAP Services*, **YES**, *Enter Address*, **YES**.
2. Enter the address, for example

**mobileinternet.ericsson.com** and press **YES**.



### Options While You are Browsing

While you are browsing you can press and hold **YES** to reach an options menu. The menu may look different depending on what page you are browsing. It can, for example contain special features of the WAP page you are currently browsing. It always, however, contains the options below:

- *Go to Menu.* Go back to the WAP services menu where you can access your bookmarks among other things.
- *Reload page.* Get the latest version of the WAP page

### *To return to the browser*

- Scroll to *WAP Services*, **YES**, *Resume*, **YES**.

### Bookmarks

If there are some WAP pages that you visit often, you can save these as bookmarks, making it easier to go to these pages.

**Note:** *You can only add bookmarks while you are browsing.*

## Images

If you do not want to display the images on the WAP page that you are browsing, you can turn them off. Images take longer to download, but the WAP page may look better with them.

If an image contains a link, you can access the link by highlighting the image, then press **YES**.

If you turn off the Show images function, the images appear as icons in the display.

4. Enter how many seconds you want the download to continue before it stops, and press **YES**.

## Using WAP Profiles

Your phone comes with three WAP profiles, in order to simplify your browsing. You can, for example associate one profile to your operator's WAP page and one to your company's intranet. Instead of having to enter the access settings, when you want to switch between your operator's WAP page and your company's intranet, you can simply switch profiles.

### *To switch WAP profiles*

1. Scroll to *WAP Services*, **YES**, *WAP Profile*, **YES**.
2. Select a WAP profile and press **YES**.  
This WAP profile is active until you switch again.

### **Renaming a WAP Profile**

You can change the name of your WAP profiles to a name of your own choice.

### *To change the name of a WAP profile*

1. Scroll to *WAP Services*. **YES**. *WAP Settings*. **YES**.

## **Profiles**

A profile is a group of settings which are set to suit a certain environment. For example, when you go to a meeting, you can simply choose the *Meeting* profile and a number of settings that suit a meeting are set – the ring signal is turned off etc.

Some phone accessories can activate a profile automatically. For example, when you place your phone in a car handsfree unit, the *In Car* profile is activated.

You cannot change the name of or add any accessories to the *Normal* profile.

*To choose a profile manually*

1. Scroll to *Settings*, **YES**, *Profiles*, **YES**, *Select Profile*, **YES**.
2. Select a profile and press **YES**.

*To change the name of a profile*

1. Scroll to *Settings*, **YES**, *Profiles*, **YES**, *Edit Profile*, **YES**, *Profile Name*, **YES**.
2. Enter a new name and press **YES**.

phone from the accessory, the profile is changed back to the one which was active before, if the current profile was activated automatically.

When you buy your phone, the automatic activation is set to on for the Car and Portable handsfree profiles.

*To turn automatic activation on or off*

1. Scroll to *Settings*, **YES**, *Profiles*, **YES**, *Edit Profile*, **YES**, *Auto Activation*, **YES**.
2. Select *On* or *Off* and press **YES**.

## Voice Control

With your phone you can:

- voice dial – call someone by saying the name.
- answer and reject calls by using your voice when connected to handsfree equipment.

### Preparing Your Phone for Voice Dialling

Before you can use voice dialling, you need to record voice labels for your phone book entries. When

### Recording Problems

If your phone cannot detect any speech, one of the following might have happened:

- you spoke too softly – try speaking more loudly
- the voice label was too short – it should be around one second long
- you spoke too late or too soon – speak after the tone

*To make a call using your voice*

1. Press and hold **YES** until you hear a tone.
2. Release **YES** and say a name you have recorded earlier.

*To edit a voice label*

1. Scroll to *Phone Book*, **YES**, *Voice Labels*, **YES**.
2. Select an entry and press **YES**.
3. Select *Replace Voice* or *Erase Voice* and press **YES**.

*To turn Voice Dialling on or off*

1. Scroll to *Settings*, **YES**, *Voice Control*, **YES**, *Voice Dialling*, **YES**.
2. Select *On* or *Off* and press **YES**.

save your recording. If the recording was not OK, repeat step 3.

5. Say the word “busy” (or another word) and press **YES** to save your recordings.  
These are the commands you use to answer or reject calls.

*To answer or reject an incoming call using your voice*

- When the phone rings, say the word **Answer** or **Busy**.

## Diverting Incoming Calls

If you cannot answer an incoming voice, fax or data call, you can divert it to another number.

For voice calls, (not fax and data) you can choose between the following divert alternatives:

- *All Voice Calls* – divert all voice calls.
- *When Busy* – divert calls if you are already on the phone.
- *Not Reachable* – divert calls if your phone is turned off or if you are unreachable.

### *To turn off a call divert*

1. Scroll to *Settings*, **YES**, *Call Options*, **YES**, *Divert Calls*, **YES**.
2. Scroll to a divert option and press **YES**.
3. Select *Cancel* and press **YES**.
  - Select *Get Status* to check if a divert option is on or off.

You can check the status of all divert options.

- Select *Check All* from the *Settings/Call Options/Divert Calls* menu.

## Handling More Than One Call Simultaneously

Your phone can handle more than one call simultaneously. You can, for example, put an ongoing call on hold while you make or answer a second call, and then switch between the two calls.

You can also set up a conference call to have a joint conversation with up to five people.

2. Enter the number you wish to call and press **YES**. Press and hold  to retrieve a number from the phone book.

**Note:** *You can only put one call on hold.*

### Receiving a Second Call

If the Call Waiting service is on, you hear a beep in the earpiece if you receive a second call. A list of alternatives, *Answer*, *Busy* and *Release&Answer*, is shown in the display. You can do one of the following:



### **One Active Call and One Call On Hold**

When you have one active call and one call on hold, you can do one of the following:

*To switch between the two calls*

- Press **YES**.

*To end the active call and return to the call on hold*

1. Press **NO**.
2. Press **YES**.

*To end the current call and accept the waiting call*

- Select *Release&Answer*.  
The waiting call becomes active and the call on hold remains on hold.

*To reject the waiting call*

- Select *Busy*.

### **Conference Calls**

You can include up to five participants in a conference call. To create a conference call,



You can extract one participant from the conference call for a private conversation and put the other participants on hold.

*To extract a participant*

1. Scroll to *Ongoing Call*, **YES**, *Extract Part*, **YES**.
2. Select a participant and press **YES**.

*To rejoin the participant*

- Scroll to *Ongoing Call*, **YES**, *Join Calls*, **YES**.

## Call Time and Call Cost

During a call, the duration of the call is shown in the display. If you subscribe to cost information, the call cost (or the number of call units) is displayed instead.

### Call Time

You can check the duration of your *Last Call*, *Outgoing Calls*, *Incoming Calls* and the *Total Time*.

*To check the call time*

**Note:** *If you subscribe to cost information, you must enter your PIN2 to clear the cost or time counter.*

### **SMS Counter**

You can check the number of text messages that you have sent.

*To check the number of sent messages*

- Scroll to *Call Info*, **YES**, *Call Costs*, **YES**, *Sent SMS*, **YES**. Select *Clear Msg Count* to reset the counter.

### **Credit Limit for Calls**

If supported by your network and your subscription, you can enter a total amount of money that can be used for making calls. When the amount reaches zero, no more calls can be made. Please note that the credit limit is only an estimated value.

*To set a specific credit limit*

1. Scroll to *Call Info*, **YES**, *Call Costs*, **YES**, *Set Credit*, **YES**.
2. Enter your PIN2 and press **YES**.
3. Select *Change Credit* and press **YES**.

## Security for Your Phone and Subscription

### The SIM Card Lock

The SIM card lock protects your subscription, but not your phone itself, from unauthorized use. If you change SIM cards, the phone still works with the new SIM card.

Most SIM cards are locked at the time of purchase. If the SIM card lock is on, you have to enter a “PIN”

### To change your PIN

1. Scroll to *Settings*, **YES**, *Locks*, **YES**, *Card Lock*, **YES**, *Change PIN*, **YES**.
2. Enter your old (current) PIN and press **YES**.
3. Enter your new PIN and press **YES**.
4. Re-enter the new PIN to confirm and press **YES**.

**Note:** If the message “Codes do not match” appears, you entered the new PIN incorrectly. If the message “Wrong PIN” appears, followed by “Old PIN:”, you entered your old PIN incorrectly.

not on when you buy the phone. You can change the phone lock code (0000) to any four- to eight-digit personal code. The phone lock can be set to on, automatic or off.

### Phone Lock On

If the phone lock is on, the message *Phone locked* *Phone lock code:* appears each time you turn on the phone. You have to enter your code followed by **YES** to use your phone.

### To set the phone lock

1. Scroll to *Settings*, **YES**, *Locks*, **YES**, *Phone Lock*, **YES**, *Protection*, **YES**.
2. Select an alternative and press **YES**.
3. Enter the phone lock code and press **YES**.

### Restrict Calls

The Restrict Calls service allows you to restrict certain types of calls being made and received.

You need a password, which comes with your subscription, to activate or cancel a call restriction.



3. Select *Activate* or *Cancel* and press **YES**.
4. Enter your password and press **YES**.

- To check the status of a call restriction, select the call restriction and then *Get Status*.
- To turn off all call restrictions, select *Cancel All*.
- To change the password, select *Change Passwd*.

**Note:** *If you divert incoming calls, you cannot activate some Restrict Calls options. Likewise, if you restrict calls, you cannot activate some Divert Calls options.*

made to numbers from 0123456700 to 0123456790.  
To enter a question mark, press and hold #.

**Note:** *Calls to the international emergency number 112 can still be made, even when Fixed Dialling is on.*

*To turn Fixed Dialling on or off*

1. Scroll to *Phone Book*, **YES**, *Options*, **YES**, *Fixed Dialling*, **YES**.
2. Enter your PIN2 and press **YES**.
3. Select *On* or *Off* and press **YES**.

2. Scroll to *Add new?* and press **YES**.
3. Enter the name of the user group and press **YES**.
4. Enter the index number and press **YES**.  
You get the index number from your operator.

*To activate a group*

1. Scroll to *Settings*, **YES**, *Call Options*, **YES**, *Closed Groups*, **YES**, *Edit List*, **YES**.
2. Select a group and press **YES**.
3. Select *Activate* and press **YES**.

**Calls can only be made within the selected group.**

*To add numbers to the Accepted Callers List*

1. Scroll to *Settings*, **YES**, *Call Options*, **YES**, *Accept Calls*, **YES**, *Accepted List*, **YES**.
2. Scroll to *Add new?*, **YES**.  
This takes you to the phone book.
3. Select an entry and press **YES**.

*To set the accept calls option*

1. Scroll to *Settings*, **YES**, *Call Options*, **YES**, *Accept Calls*, **YES**, *Accept Options*, **YES**.
2. Select an option and press **YES**.

## Using Two Voice Lines

If you subscribe to the “Two Line Service”, you can choose which line you want to use for outgoing calls. Incoming calls can be received on both lines, irrespective of the line currently chosen.

When you buy your phone, the names of the lines are normally Line 1 and Line 2. You can have different settings for your two lines, for example, ring signal, call divert.



## Calling Card Calls

The Calling Card Service lets you redirect the charges to either a credit card account or to a calling card account, instead of your normal account.

You can save two separate calling card numbers in your phone. The numbers are protected by the phone lock code. See “The Phone Lock” on page 52.

**Note:** *You cannot use the Calling Card Service for*



### *To save a card number*

1. Scroll to *Phone Book*, **YES**, *Calling Cards*, **YES**.
2. Enter your phone lock code and press **YES**.
3. Select *Add new?* and press **YES**.
4. Enter the access number of the calling card server and press **YES**.
5. Enter a name and press **YES**.
6. Enter the verification code of the calling card server and press **YES**.
7. Select which you want to send first – the number you want to call or the verification – and press **YES**.

### **Making a Calling Card Call**

1. Enter the phone number of the person you want to call.
2. Press and hold **YES**.  
The access number of the calling card server is called. During the connecting phase, you are asked to send the phone number you want to call and the verification code, in the order chosen earlier.
3. Press **YES** when the display shows *Send* or wait a few seconds and the number and code are sent automatically.

## Setting Network Preferences

When you turn on the phone, it automatically searches for your home network. If this is not within range, you may use another network, provided your network operator has an agreement that allows you to do so. This is called roaming.



### To select a network

1. Scroll to *Settings*, **YES**, *Networks*, **YES**, *Select Network*, **YES**.

- To see a network's full name, select the network and then select *Full Name*.

### To add a network to the list

1. Scroll to *Settings*, **YES**, *Networks*, **YES**, *Preferred Nets*, **YES**, *Add new?*, **YES**.
2. Select the network you want and press **YES**.
3. If the network you want does not appear in the list, scroll to *Other* and press **YES**.
4. Enter the three-digit country number and the two-digit network number and press **YES**.

- **Manual search mode** means that your phone first searches for the last accessed network, but if this is not available, the question *Select net?* appears. You then need to choose a network as described in “To select a network” on page 58.

*To select automatic or manual search mode*

- Select *Automatic* or *Manual* from the *Settings/Networks/Search Mode* menu and press **YES**.

## Fax and Data Calls

### Sending Fax and Data Calls

To send fax and data calls you need to connect your phone to a computer, and then start the appropriate software program.

### Receiving Fax and Data Calls

The procedure of receiving fax and data calls depends on your network and subscription. If you have separate numbers for voice, fax and data calls, your phone

If you want to receive a fax or data call you have to set the phone to one of these options. Once you have set your phone for a specific incoming call, it stays like this until you change it.

*To set the next incoming call type*

1. Scroll to *Call Info*, **YES**, *Next Call*, **YES**, *Next Incoming*, **YES**.
2. Select the call type you want and press **YES**.

## Extras

### Alarm Clock

The phone has an alarm clock which rings at the time set, even if the phone is turned off. The alarm rings for 60 seconds and is repeated every nine minutes for 60 minutes if you do not turn it off.

*To set the alarm*

1. Scroll to *Extras*, **YES**, *Alarm Clock*, **YES**.
2. Enter the time and press **YES**.

### *To change the alarm signal*

1. Scroll to *Settings*, **YES**, *Sounds & Alerts*, **YES**, *Alarm Signal*, **YES**.
2. Select a signal and press **YES**.

### **Internet Time Alarm**

If you have turned Internet time on, you can set the alarm clock to ring at a certain Internet time.

### *To set the alarm in Internet time*

1. Scroll to *Extras*, **YES**, *Alarm Clock*, **YES**, *Internet*

### *To use the calculator*

In this example, we are going to divide 134 by 32.

1. Scroll to *Extras*, **YES**, *Calculator*, **YES**.
2. Enter 134.
3. Press **#** repeatedly until the division sign (*/*) appears.
4. Enter 32.
5. Press **YES** to get the answer.
6. To clear the display, press **c**.

### **Stopwatch**

The phone has a built-in stopwatch.

### Timer

The phone has a built-in 24-hour timer. You set the time you want and when that time is up, the phone beeps.

#### *To set the timer*

1. Scroll to *Extras*, **YES**, *Timer*, **YES**.
2. Enter the time and press **YES** to start the timer.
3. When the alert sounds, press any key to turn it off.

#### *To control Tetris*

- **8** or slide the volume key downwards = move left
- **2** or slide the volume key upwards = move right
- **5** or **9** = rotate
- **3** or **6** = drop faster
- **c** = pause
- **NO** = quit

Tetris®; © Elorg 1987. Classic Tetris™; © Elorg 1998. Tetris Logo by Roger Dean; © The Tetris Company 1997. All Rights Reserved.

2. Select *New Game* and press **YES**.

Instead of selecting a *New Game*, you can select *Difficulty*, *Help*, *High-score* or *Resume Game* by pressing  at step 2. Slide the volume key to switch difficulty level.

### E-Maze

The object of E-Maze is to eat all the “dots” and avoid being eaten by the monsters. When you eat any of the “bullets” in the corner, you can fire at the enemies.

Collect the diamond, when it appears, for bonus points.

### Ballpop

The object of Ballpop is to prevent blocks from reaching the left side of the display. You do this by using a bat to bounce a ball against the blocks. Some blocks need to be hit more than once before they go away. At regular intervals, a new row of blocks is added. A row is also added when the ball hits the left-hand wall. If a block touches the bat or the left-hand wall, you lose a life. Some blocks appear as icons. When the ball hits these, a new characteristic is added to the bat, for example it is turned into a multiball, a

### *To control Ballpop*

- **8** or slide the volume key downwards = move the bat downwards
- **2** or slide the volume key upwards = move the bat upwards
- **5** = to fire shots when the bat is a cannon

## Online Services

The Online Services is the network operators' way of offering customized services, independently of mobile phones and mobile phone manufacturers.



### New Menu

A SIM card which supports the Online Services works in the same way as a normal SIM card.

When you have inserted your SIM card and turned



### Data Download to the SIM

Your network operator can at any time download new data, for example a new feature, to your SIM card over the air.

### Resetting Your SIM Card

When the operator updates your SIM card over the air, the phone notifies you by showing a message in your display. You also hear a beep. The message can, for example, prompt you to make a call or send a text message (SMS).

## Ericsson Mobile Internet





The **Mobile Internet** is a service supplied by Ericsson to make it easier for you to communicate and receive information quickly, wherever you are. It gives you access to various messaging services, on-line customer services, user manuals and other useful information. With the **Mobile Internet** you can also download communications software to ensure you get the best out of your Ericsson products.

## Troubleshooting

This chapter lists some problems that you might encounter while using your phone. Some problems require that you call your service provider, but most of the problems you can easily correct yourself.

### The Phone Cannot Be Switched On Hand-held Phone

- Recharge or replace the battery. See “The Battery”

(determined by your SIM card) by pressing  8888  in standby. You can always choose English by pressing  0000  in standby.

### Error Messages

#### Insert Card

There is no SIM card in the phone or you may have inserted it incorrectly. Insert a SIM card. See “The SIM Card” on page 4.

#### Insert Correct SIM Card

### Wrong PIN, Wrong PIN2

You have entered your PIN or PIN2 incorrectly.

- Enter the correct PIN or PIN2, and press **YES**.  
See “The SIM Card Lock” on page 52.

### Codes Do Not Match

When you want to change a security code (for example your PIN) you have to confirm the new code by entering it again. The two codes that you have entered do not match. See “The SIM Card Lock” on page 52.

### Phone Lock Code:



Your phone comes with the phone lock code, 0000. You can change it to any four- to eight-digit code. See “The Phone Lock” on page 52.





### Number Not Permitted

The Fixed Dialling function is on and the number you have dialled is not on your fixed numbers list. See “Fixed Dialling” on page 54.

### Charging Alien Battery

## Display Icons

Symbol	Description
	Network signal indicator.
	Battery status indicator.
	The ring signal is turned off.

Symbol	Description
	Indicates an answered call in the call list.
	Indicates a dialed number in the call list.
	Line 1 is in use for outgoing calls.
	Line 2 is in use for outgoing calls.
	The phone book entry is saved in the phone

Symbol	Description
--------	-------------



	Voice label recorded for that entry. Voice dialling is set to Start on Flip.
--	---

	Preferred network.
--	--------------------

	Forbidden network.
--	--------------------

	Your home network is within range.
--	------------------------------------

## Quick Keys

To...	Do this:
enter the <i>Call List</i>	press <b>YES</b> from standby
to enter the first function in the menu <i>My Shortcuts</i>	press and hold  from standby
to enter the <i>Find and Call</i> menu	press and hold  from standby
voice dial	press and hold <b>YES</b> from standby

**To...**

**Do this:**

find a phone book entry beginning with the first letter (or the closest following) on a key

press and hold any of the keys **2–9** from standby

find a phone book entry

enter the position number and press **#** from standby

put a call on hold

press **YES**

switch between two calls

press **YES**

## Technical Data

### General

Product name	T20s/T20sc
System	GSM 900/GSM 1800
SIM Card	Small plug in card 3V or 5V

## Guidelines for Safe and Efficient Use

*Note: Read this information before using your mobile phone.*

### Product Care and Maintenance

Your mobile phone is a highly sophisticated electronic device. To get the most out of your mobile phone read this text about product care, safe and efficient use.

- **Do not** use any other accessories than Ericsson originals. Failure to do so may result in loss of performance, damage to the product, fire, electric shock or injury, and will void the warranty.
- **Treat your product with care, keep it in a clean and dust free place. Only use a soft damp cloth to clean your product.**

### Antenna Care and Replacement

- To avoid impaired performance please ensure your mobile phone's antenna is not bent or damaged.
- Do not remove the antenna yourself. If your phone's

- Do not hold the antenna when the phone is in use. Holding the antenna affects call quality, may cause the phone to operate at a higher power level than needed and shorten talk and standby times. If your mobile phone is equipped with an infrared eye, never direct the infrared ray at anyone's eye and make sure that it does not disturb any other infrared units.

### **Radio Frequency Energy**

Your mobile phone is a radio transmitter and receiver. When the phone is turned on, it receives and transmits radio frequency (RF) energy. Depending on the type of

telephones conform to the ICNIRP guidelines and other international exposure standards, such as:

- CENELEC European Pre-standard ENV50166-2:1995 (Europe)
- ANSI/IEEE C95.1-1992 (USA, Asia-Pacific)
- AS/NZS 2772.1 (Int):1998 (Australia, New Zealand)

### **Driving**

Check the laws and regulations on the use of mobile phones in the areas where you drive. If you are going to use your phone while driving, please:

- Give full attention to driving.



### Vehicles Equipped with an Air Bag

An air bag inflates with great force. Do not place objects, including either installed or portable wireless equipment, in the area over the air bag or in the air bag deployment area. If in-vehicle wireless equipment is improperly installed and the air bag inflates, serious injury could result.

### Electronic Devices

Most modern electronic equipment, for example equipment in hospitals and cars, is shielded from RF energy. However, certain electronic equipment is not,

Contact your cardiologist for more information.

Some hearing aids might be disturbed by mobile phones. In the event of such disturbance contact your local Ericsson Call-Centre to discuss alternatives.

### Aircraft

- Turn off your mobile phone before boarding any aircraft.
- Do not use it on the ground without crew permission.

To prevent interference with communication systems, you must not use your mobile phone while the plane is in the air.

boats, fuel or chemical transfer or storage facilities, and areas where the air contains chemicals or particles, such as grain, dust, or metal powders.

Do not transport or store flammable gas, liquid, or explosives in the compartment of your vehicle, which contains your mobile phone and accessories.

### **Power Supply**

- Connect AC (Power supply) only to designated power sources as marked on the product.
- To reduce risk of damage to the electric cord, remove it from the outlet by holding onto the AC adapter rather

### **Emergency Calls IMPORTANT!**

This phone, like any mobile phone, operates using radio signals, cellular and landline networks as well as user-programmed functions, which cannot guarantee connection under all conditions. Therefore you should never rely solely upon any mobile phone for essential communications (e.g. medical emergencies).

Remember, in order to make or receive calls the phone must be switched on and in a service area with adequate cellular signal strength. Emergency calls may not be possible on all cellular phone networks or when

phone is used nearby a base station less power is required and talk and standby times are prolonged.

- Use only Ericsson original batteries and chargers. Using non-original Ericsson accessories could be dangerous and the warranty does not cover product failures which have been caused by use of non-Ericsson original accessories.
- Do not expose your battery to extreme temperatures, never above +60°C (+140°F). For maximum battery capacity use your battery in room temperature. If the battery is used in cold temperatures the battery capacity will be reduced.

### **Recycling Your Battery**

The battery must be disposed of properly and should never be placed in municipal waste. Check local regulations for proper disposal instructions.

## Limited Warranty

Thank you for purchasing this Ericsson Product. To get maximum use of the features of your new product we recommend that you follow a few simple steps:

- Read the Guidelines for Safe and Efficient use.
- Read all the terms and conditions of your Ericsson Warranty.
- Save your original receipt. You will need it for warranty repair claims. Should your Ericsson Product need warranty service, you should return it to the dealer from whom it was purchased or contact your local Ericsson

option, either repair or replace the Product in accordance with the terms and conditions stipulated herein.

### Conditions

1. The warranty is valid only if the original receipt issued to the original purchaser by the dealer, specifying the date of purchase and serial number, is presented with the Product to be repaired or replaced. Ericsson reserves the right to refuse warranty service if this information has been removed or changed after the original purchase of the Product from the dealer.
2. If Ericsson repairs or replaces the Product, the repaired

or opening of the Product by non-Ericsson certified persons.

5. The warranty does not cover Product failures which have been caused by use of non-Ericsson original accessories.
6. Tampering with any of the seals on the Product will void the warranty.
7. THERE ARE NO OTHER EXPRESS WARRANTIES, WHETHER WRITTEN OR ORAL, OTHER THAN THIS PRINTED LIMITED WARRANTY. ALL IMPLIED WARRANTIES, INCLUDING WITHOUT LIMITATION THE IMPLIED WARRANTIES OR MERCHANTABILITY OR FITNESS FOR A PARTICULAR PURPOSE, ARE

that certain services may not be possible to have made elsewhere than in the country of original purchase for example due to the fact that your Ericsson Product may have an interior or exterior which is different from equivalent models sold in other countries. There may also be limited possibilities to repair SIM-locked Products.

Some countries do not allow the exclusion or limitation of incidental or consequential damage, or limitation of the duration of implied warranties, so the preceding limitations or exclusions may not apply to you. This warranty gives you specific legal rights, and you may also have other rights which may vary from country to

## **Declaration of Conformity**

**We, Ericsson Mobile Communications AB of  
Nya Vattentorget  
221 83 Lund, Sweden**

declare under our sole responsibility that our product

**Ericsson type 110 1401-BV**

## Index

### A

Accept calls 55  
Alarm clock 60  
    Internet time 61  
    setting time 60  
    turning off 60  
Alarm indicator 68  
Alarm signal 61

Downloaded from [www.Manualslib.com](http://www.Manualslib.com) manuals search engine

charging 7  
disconnecting the charger 8

Battery indicator 68  
Bookmarks 41  
    adding a bookmark 41

### C

Calculator 61  
Call barring. See Restrict calls  
Call cost 50  
    setting a credit limit 51

Calling card services 56  
    activating 56  
Calling Line Identification (CLI)  
service 11

### Calls

answering 11, 13  
conference 49  
emergency 10  
ending 9  
hiding your number 12  
international 10

Conference calls 49  
  adding a participant 49  
  extracting a participant 50  
  releasing a participant 50  
  releasing all participants 50  
  setting up 49  
Converting Internet time 30  
Credit card calls 56  
  making a call 57  
  saving a number 57

**E**  
Earpiece volume 9  
E-Maze 63  
Emergency calls 10  
Emergency numbers 11  
Ending a call 9  
Entering letters 18  
Erix 62

**F**  
Fax

**H**  
Handsfree 30  
Help texts 16  
Hiding your number 12

**I**  
International calls 10  
International emergency number 10  
Internet time 30  
  converting 30  
  setting alarm clock 61



## **M**

Making a call 9  
Master reset 32  
Menus 14  
  display text 15  
  leaving a menu 14  
  moving (scrolling) through 14  
  phone book 19  
  selecting a menu 14  
  shortcuts 15  
Message signal 28

## **N**

Network 58  
  preferred 58  
  search modes 58  
  selecting 58  
Notepad 12

## **O**

Online services 64  
Opening a homepage 40  
Opening a WAP page 40

memory 21  
  overwrite protection 22  
  phone memory 21  
  saving a number 19  
  shortcuts 20  
  sort order 21  
Phone lock  
  activating/cancelling 53  
  auto lock 53  
  changing the security code 53  
  on 53

Re-dialling 10  
  automatic 10  
Rejecting a call 11  
Request reply (SMS) 34  
Restrict calls 53

  changing password 54  
  changing status 53

Ring signal  
  choosing 26  
  composing own melody 27

  increasing ring 26

  resetting 65  
  unblocking 52  
SIM card lock  
  activating/cancelling 52  
SMS. See Text messages

SOS calls 10  
SOS numbers 11  
Standby mode 9  
Strap

  attaching 8  
Switching between two calls 49

  format 29  
  internet time 30  
  setting the time 29

Tone signals  
  turning off 12  
Turning microphone off 10  
Turning phone off 10  
Turning phone on 9

**V**  
Vibrating alert 28

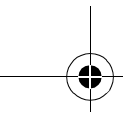

opening a homepage 40  
opening a WAP page 40  
preparing the phone 37  
WAP profiles 42

Commercial Use