

Electrical repair manual

K800



K810



ABOUT

General information

The purpose of this document is to provide enhanced technical information for Sony Ericsson repair technicians in order to assist during service, repair and troubleshooting operations on Sony Ericsson mobile phones. It should be used as a complement to other repair instructions and tools as notified by the local Sony Ericsson representative.

To search for components throughout the entire document use the "search" function in Adobe Acrobat Reader 7.0 (or later version) and enter the component name or other word. Use zoom to enlarge.

For easier navigation of the document you can use the bookmarks that appear in the Bookmarks tab on the left side of the Adobe Acrobat Reader window. Each bookmark jumps to a page in the document.

Instruments used

- Power supply Agilent 6632B
- Power supply.....Agilent 66311B
Power supply set to 3,8V and limited to 2A
- Oscilloscope Tektronix TDS 2012
- MultimeterFluke 83
- Spectrum Analyzer..Hewlett Packard 8596E
- Mobile Phone Tester.....Yokogawa VC230

Disclaimer

This document is Sony Ericsson confidential and should be treated as confidential in accordance with the agreement with Sony Ericsson. This document is intended for use by authorized service technicians only. Sony Ericsson is not to be held responsible for any damages or losses caused intentionally or unintentionally due to unauthorised use of the information in this document.

Revision History

Rev.	Date	Changes / Comments
1	6/29/2007	Initial revision.

CONTENTS

ABOUT	2	Flash Problems - Audio Internal Problems	53
General Information	2	Audio External Problems - Camera Problems	54
Contents	2	FM Radio Problems - Vibrator Problems	55
FUNCTION OVERVIEW	3	Memory Stick Problems - Bluetooth Problems	56
Description	3	Network Problems - Display Problems	57
General	3	Test Current Consumptions	58
Mechanical Design	3	Test Charging	58
RF Parts	3	Test the ASIC Revisions	59
Logic/Audio Part	5	Test Backup Capacitor	59
Antenna	5	Test the Joystick Switch S2504 and Diodes V2503, V2506-09	60
Bluetooth	5	Test the Diode V2500	61
IR	6	Test the Protection Diodes V2510 to V2514	61
FM Radio	6	Test the diode V2504 and Switch S2500	62
External Connections	6	Test the Switches S2505 & S2506	62
High Level	7	Test the Switch S2502	63
Radio	8	Test the Switches S2503 & S2507	63
Baseband	9	Joystick and Other Keys Problems	64
Data and Signals	10	Test the System Connector Protections	64
Acoustics	11	Reference MP	65
Power Distribution	12	APPENDIX	66
Baseband Top - Radio Top - Bluetooth - FM Radio	13	K800 Mechanical Parts List	66
Radio - Top	14	K810 Mechanical Parts List	70
Radio - Power Supply	15	Part List Main Board	73
Radio - UMTS	16	Components A1200	74
Radio - GSM	17	Components A1300	83
Radio - Bluetooth	18	Components B2100, B4100	90
Baseband - Logic Top	19	Components C2217, D1400	91
Baseband - System Control Top	20	Components D2301, D2304	92
Baseband - System Control Clocks and Resets	21	Components H2300, D3100, D3101	93
Baseband - System Control Test	22	Components N2000, N2200	94
Baseband - Power Top	23	Components N2202, N2203, N2300	95
Baseband - Regulators and Charging	24	Components N2600, N3100, N4100	96
Baseband - Power Camera	25	Components N4202, S2500, S2502	97
Baseband - Power ASICs	26	Components S2504, S2505, S2506	98
Baseband - Power Memories	27	Components V2201, V2202	99
Baseband - Operation & Services Top	28	Components V2220, V2301, V2552	100
Baseband - Operation & Services Memories	29	Components V2500, V4101, V2504	101
Baseband - Operation & Services GPIO	30	Components V3101, V3102	102
Baseband - Operation & Services ADC & DAC	31	Components V3103, V3110	103
Baseband - Operation & Services MS Pico & SIM	32	Components V3113, X1000	104
Baseband - Operation & Services Connectivity	33	Components X1002, X2200	105
Baseband - UMTS Access Top	34	Components X2301, X2302	106
Baseband - UMTS Access WCDMA	35	Components X2501, X2505, X2510	107
Baseband - UMTS Access GSM	36	Components X2550, X3102	108
Baseband - MMI Top	37	Keyboard K800	109
Baseband - MMI Keypad	38	Keyboard K810	110
Baseband - MMI Display	39	Display	111
Baseband - MMI Audio	40	VGA Camera KNC20116	112
Baseband - MMI Camera	41	Camera Module KNC20125	112
Baseband - MMI FM Radio	42	Xeon Flash Module	113
COMPONENT OVERVIEW	43	SI Can't Power On	114
Front Side B - C	43	SI Can't Power On	115
Front Side D - Z	44	SI Joystick Switch Replacement	116
Back Side A - Z	45	SI Support Pad for Camera Switch	116
SAMPLE POINTS	46	SI Problem with Front Spare Part	117
Front Side	46	SI Problem with On/Off Button	117
Back Side	47	SI Emma 3 White Screen Patch	118
TROUBLESHOOTER	48	SI Activate Sporadic Behaviour	118
Repair Actions	48	SI Pre-Configuration Change	119
Repair Actions	49	SI Vincenne Replacement	120
On/Off - Dead Phone	50	SI Emma 3 Important Start-Up Operation, SI New Software	120
Charging Problems - VBUS Charging Problems	51	Torque Settings	121
Keyboard & Display Backlight - SIM	52	Placing in a Shield Box	121

DESCRIPTION

1 General

The Sony Ericsson Mobile Communication phone K800 is a 3G dual mode mobile phone supporting WCDMA and triple band GSM/GPRS in the 900, 1800 and 1900 frequency bands. The phone is a GPRS class 10 terminal supporting voice, circuit switched (CS) and packet switched (PS) data. This Sony Ericsson dual mode 3G product is designed to be compatible with all mandatory GSM phase 2+ recommendations.

The phone has an in-built antenna, a 3.2 Mega Pixel Camera with a lens cover and an associated xenon flash, a VGA-Camera for Video Call, a Display, and a slot for a Memory Stick M2 external memory.

There is only one size of battery. A connector at the bottom of the phone makes it possible to connect various accessories like chargers and hands-free units. A USB cable can also be connected to the bottom connector. The external antenna connector can be used to connect to an external antenna, disconnecting the internal phone antenna.

The electronic functions are divided into RF parts, logic/audio parts, opto-electronic parts, Bluetooth parts, an IR transceiver, and an FM radio. The electronics parts consists of the main PCB with components placed on both sides, the Key-Flexible-PCB that has Key-Matrix-circuit/LEDs, loudspeaker box with the internal antenna, ear speaker, microphone, vibrator, 3.2 mega pixel camera, xenon flash module, VGA camera, the Display, Bluetooth module, and FM radio parts. The RF parts are mainly housed in separate modules.

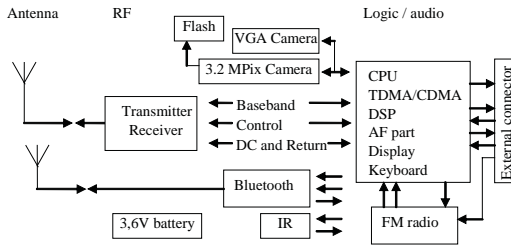

Figure 1. Block diagram of the K800.

2 Transceiver

This description provides only a simple general description of the transceiver section and its components.

2.1 Mechanical Design

The phone is built up around a core unit consisting of a plastic frame with the BT antenna mounted on which the assembled PCB, the cameras, the vibrator, a plastic LCD holder and the LCD, a plastic keyboard support plate and the keyboard dome foil, the loud speaker box with loudspeaker and antenna, and the xenon flash module are mounted. This core unit is then snapped and screwed in the front cover together with the keys, joystick, and the M2 cover. The antenna cover with the sliding camera lens cover is then mounted. The battery fits in a dedicated cavity and is covered with a battery cover.

Dimensions

Length	106mm
Width	47mm
Thickness	18mm (22mm across the lens cover)
Weight	115g

2.2 RF parts

2.2.1 GSM 900

The GSM 900 part of the transceiver is including E-GSM and has a frequency range spanning from 925.2 to 959.8 MHz for the receiver, and from 880.2 to 914.8 MHz for the transmitter. This gives 174 channels with 200kHz channel separation. The TX – RX frequency separation is always 45MHz.

2.2.2 GSM 1800

The GSM 1800 part of the transceiver has a frequency range spanning from 1805.2 to 1879.8 MHz for the receiver, and from 1710.2 to 1784.8 MHz for the transmitter. This gives 374 channels with 200kHz channel separation. The TX – RX frequency separation is always 95MHz.

2.2.3 GSM 1900

The GSM 1900 part of the transceiver has a frequency range spanning from 1930.2 to 1989.8 MHz for the receiver, and from 1850.2 to 1909.8 MHz for the transmitter. This gives 299 channels with 200kHz channel separation. The TX – RX frequency separation is always 80MHz.

2.2.4 WCDMA

The WCDMA part of the transceiver has a frequency range spanning from 2110 to 2170 MHz for the receiver, and from 1920 to 1980 MHz for the transmitter. This gives 12 channels with 5MHz channel separation. The TX – RX frequency separation is always 190MHz.

2.2.5 RF architecture

VCXO

A voltage controlled crystal oscillator (VCXO) running at 13 MHz is used as a reference for all frequencies generated in the transceiver.

Antenna

The internal antenna is common for all GSM bands and the WCDMA band. There is an antenna switch between the antenna and the RF electronics allowing usage of an external antenna.

GSM 900/1800/1900

One synthesizer is used for both RX and TX operation. Direct conversion is used for RX and TX. In TX mode, the PLL works directly on the transmitted frequency, whereas the RX VCOs operates at the double received frequency. The LO is then divided by two just before entering the RX mixer.

The main component for the frequency synthesis and up-conversion is the GSM RF ASIC. A direct modulation concept is used and the base-band chip has, together with the GSM RF ASIC, all the required functions for direct modulation. The use of direct modulation means that no intermediate frequency (IF) in the transmitter chain is needed. The receiver is of direct conversion type, i.e. a homodyne receiver (the RX VCOs operates at two times the received frequency). Thus, there is no need for any other LOs than a "main loop" in this radio.

The modulated transmitter signal is amplified by a power amplifier before being routed to the front end module and the antenna.

The front end module contains all necessary functions for separating GSM and WCDMA, and routing WCDMA signals to and from the WCDMA RF module. It also contains a TX/RX switch for GSM for routing the received GSM RF signal to the correct GSM receiver input, and routing the GSM TX signal to the antenna. Band selection filtering for GSM RX is also done in the front end module.

All the GSM parts including the front end module are housed in a separate module.

WCDMA

The WCDMA receiver ASIC contains the receiver chain, the RF synthesizer and the circuitry needed for the 13 MHz crystal reference oscillator, plus the 2.3GHz RF synthesizer. The transmitter ASIC is also used to generate the IF signal (4*190MHz) needed in Rx receiver.

2.2.6 GSM/DCS/PCS Receiver

The first stage of the receiver is a band selection filter, which suppresses unwanted frequencies. The receiver is a homodyne receiver. The local oscillator frequency is generated by a frequency synthesizer, which allows the receiver to be set at frequencies in intervals of 200 kHz. The synthesizer is controlled from the logic/audio part. The receiver chip also contains A/D converters, and thus I and Q samples are sent to the logic/audio parts as serial data.

2.2.7 WCDMA Receiver

The receiver is of classical super-heterodyne type, with intermediate frequency at 190MHz.

The signal picked up from the antenna is sent, through the antenna switch (which is used to switch among GSM TX/RX, DCS TX/RX, PCS TX/RX and UMTS) to the WCDMA duplexer.

The main purpose of the WCDMA duplexer is to route the received signal from the antenna towards the receiver, while simultaneously allowing the transmitter signal from the PA to go to the antenna and limiting the leakage from the PA to the LNA inside the receiver ASIC.

The receive signal from the duplexer reaches then the LNA (integrated into the WCDMA RX ASIC) and the amplified signal is filtered by means of an external inter stage SAW filter. The filtered signal returns into the WCDMA RX ASIC to be down converted to the IF frequency, 190MHz, by means of a mixer. The first local oscillator signal is generated in the WCDMA RX ASIC and is 190MHz higher than the input signal, so it ranges between 2300 and 2360MHz.

The IF signal is filtered by an external IF SAW filter, then amplified and demodulated. After demodulation, a chain of amplifiers and low pass filters will render the analog I and Q signals. High pass filtering (needed to remove DC offset) is provided externally using series capacitors.

The analog I and Q signals are then processed by the WCDMA signal processor, that contains the 4-bit, analog to digital converters. The sampling rate is 15.36MHz, which is four times the chip rate (3.84MHz).

2.2.8 GSM/DCS/PCS Transmitter

The I and Q signals generated from the baseband is modulating the output frequency directly, this is done in the dedicated GSM/DCS/PCS RF ASIC.

An output power control loop, controlled by the logic, is regulating the output power of the power amplifier during the burst.

The transmitter has a dedicated GSM/GPRS output power control block with a logarithmic 8 bit DAC in a mixed signal ASIC, and one dual band power amplifier. The DAC is controlled by a serial bus from the GSM/GPRS baseband controller ASIC.

The PA control block applies a transfer function (2nd order low pass) to the reference value from the DAC. This new value becomes an internal reference value. The regulator in the PA control block measures I_{PA} (feed current to the power amplifier) and calculates the error signal by taking the difference between the I_{PA} and the internal reference signal. This error signal is integrated (PI-regulator) and then adjusts the PA regulator voltage to cancel the error. The PAREG signal is filtered by a low-pass to give a smooth ramping signal.

2.2.9 WCDMA Transmitter

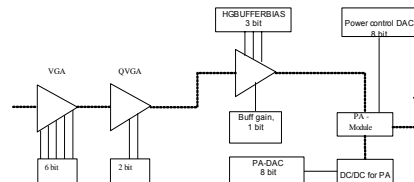

Figure 2. WCDMA transmitter.

The picture above shows in a generalized way how the WCDMA transmitter works. A TX ASIC is able to generate a dynamic range of more than 81dB while the power amplifier work as an amplifier with fixed amplification.

The VGA, QVGA and "HGBufferbias" plus "Buffgain" are all inside the TX ASIC.

The TX ASIC is the main component for controlling the power. The VGA is able to handle at least 50dB power dynamic in 1dB steps while the QVGA handles 1dB in 0.25dB steps.

"Buffgain" is a programmable PA buffer in which the bias current is optimized and finally is the buffer possible to be used in low gain mode, which generates about 30dB lower output power compared with the highest output setting.

The PA has also a variable voltage created by a DC/DC converter. By changing the PA voltage it's possible to have a better efficiency and it's done with the reference signal from a DAC.

It's also possible to change the bias current in the PA by tuning a DAC.

By combining the variable voltage and bias current it's possible to have the best current efficiency and still cope with the linear performance demands.

2.3 Logic/Audio Part

2.3.1 Functions

The purpose of the logic part is to control and monitor the transmission and reception functions of the mobile phone and to maintain contact with the mobile phone system. The logic therefore has links to all the relevant parts of the radio. Its functions, with reference to the radio, include selection of radio channel and control of the transmitter power and the overall radio timing. It also generates the base-band modulation after encryption, channel coding and demodulates the received base-band signal including equalization, decryption and channel decoding.

Its functions, with reference to the audio parts, include volume control of the earphone and loudspeaker. Speech codec and PCM A/D and D/A are also performed here, together with the appropriate audio frequency filtering.

The external tasks of the logic part include monitoring and control of links with the control unit and power supply and also the communication to the SIM/USIM and external units connected to the external connectors.

The Logic/Audio part also includes a 32.768 kHz XTAL used for the real time clock.

2.4 Antenna

The in-built antenna is made as a pattern on a flexible printed circuit foil supported by a plastic carrier containing the loudspeaker and attached to PCB. This HDA type antenna is fed via 2 contacts springs, one grounded and one connected to RF signal.

The antenna signal is also accessible through the external antenna connector located at the upper part on back of the phone.

2.5 BLUETOOTH™

The Bluetooth implementation is compliant with Bluetooth specification 2.0 + EDR

2.5.1 RF part

The Bluetooth™ transceiver has frequency channels with 1 MHz separation from 2402 to 2480 MHz. The same band is used for both transmission and reception. This gives 79 frequency channels.

2.5.2 Frequency generation

The Bluetooth™ transceiver uses the 13 MHz system clock as reference clock to the synthesizer. One synthesizer is used for both RX and TX. To separate the receiver from the transmitter an integrated antenna switch is used.

2.5.3 Receiver

The first stage of the receiver is an external antenna filter, which suppresses unwanted frequencies. The receiver is of a "near-zero" IF receiver architecture. The local oscillator is generated by a frequency synthesizer, which allows the receiver to be set at frequencies in intervals of 1 MHz. The synthesizer is controlled from the logic part.

The received signal is sampled in the logic for later signal processing.

2.5.4 Transmitter

The synthesizer generates the TX frequency which modulated by the BT baseband block. It is then amplified. The BT system is a class 1 device with maximum of +4 dBm output power (minimum setting is about -50 dBm).

2.5.5 Logic/Audio part

The purpose of the logic part is to control and monitor the transmission and reception functions of the Bluetooth™ transceiver in the mobile phone. The logic therefore has links with all the relevant parts of the radio. Its functions, with reference to the radio, include selection of radio channel and control of radio timing. It also generates the data to be sent over the link after burst building and channel coding. The logic/audio part also demodulates the received base-band signal including channel decoding.

Its functions, with reference to the audio parts, include a PCM interface.

2.5.6 Antenna

The antenna is in-built and located in the bottom part of the phone. The antenna is in contact with the PCB by means of two metal springs.

2.6 IR

The IR transceiver is IrDA compatible.

2.7 FM radio

The FM radio receiver is a stereo radio able to decode RDS information.

2.7.1 RF part

The FM radio can tune to the US/European broadcast FM frequency band, 87.5 – 108 MHz

2.7.2 Frequency generation

The FM radio receiver uses a 32.768 kHz reference clock to tune the local oscillator.

2.7.3 Receiver

The RF signal to the FM radio is first fed into a low noise amplifier. The amplified signal is then mixed with the local oscillator. The IF is of low frequency-type.

The signal is then further amplified, limited and demodulated. The demodulated signal is fed into a decoding circuitry where the right and left audio signals and RDS information are separated.

2.7.4 Logic part

The logic part of the FM radio controls the frequency tuning system, and various settings within the FM radio system. It also handles the communication, including transfer of RDS data, with the CPU of the mobile phone. The communication with the CPU is over a two-wire I²C interface.

2.7.5 Antenna

The cord to the portable hands-free headset functions as the antenna for the FM radio.

2.8 External Connectors

External units are connected to the transceiver by means of a 12-pin connector on the bottom of the phone. The pin numbering is starting from the left when looking at the system connector with the back of the phone up.

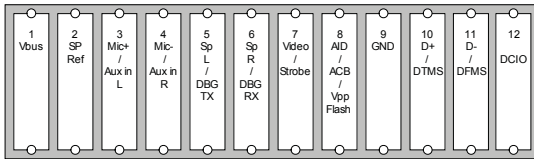
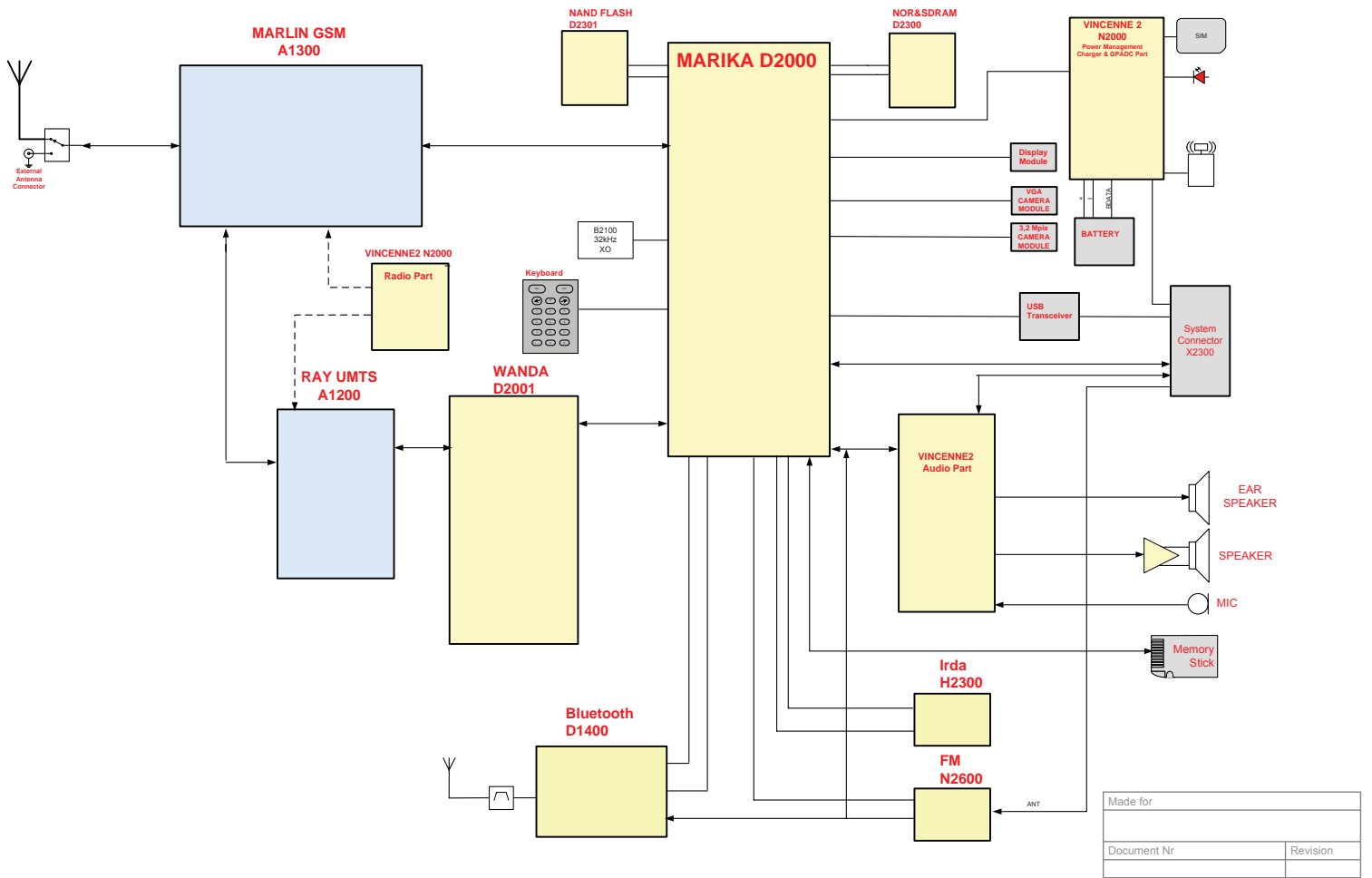
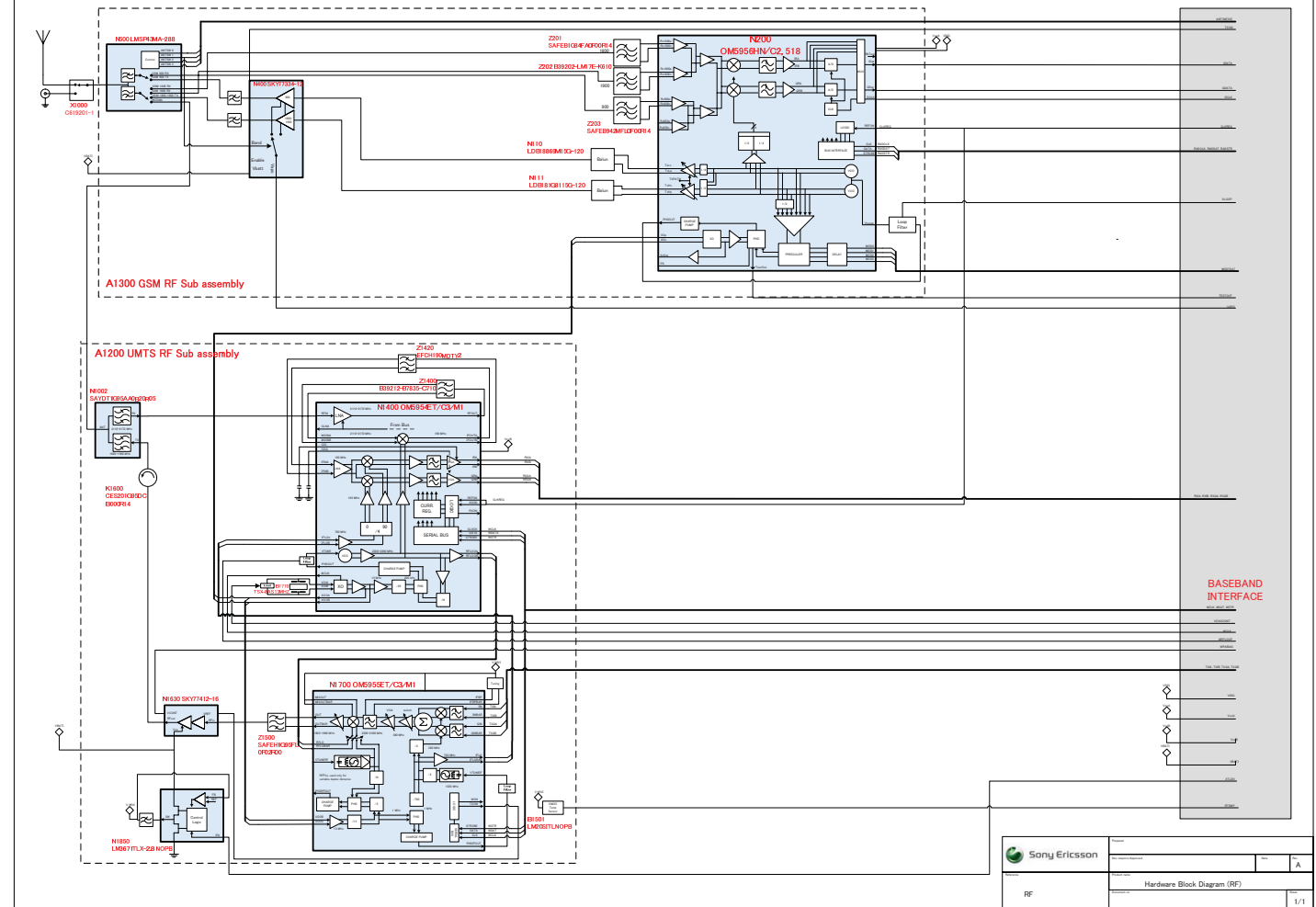

Figure 3. System connector pin out



Made for	
Document Nr	Revision

FUNCTION OVERVIEW



FUNCTION OVERVIEW

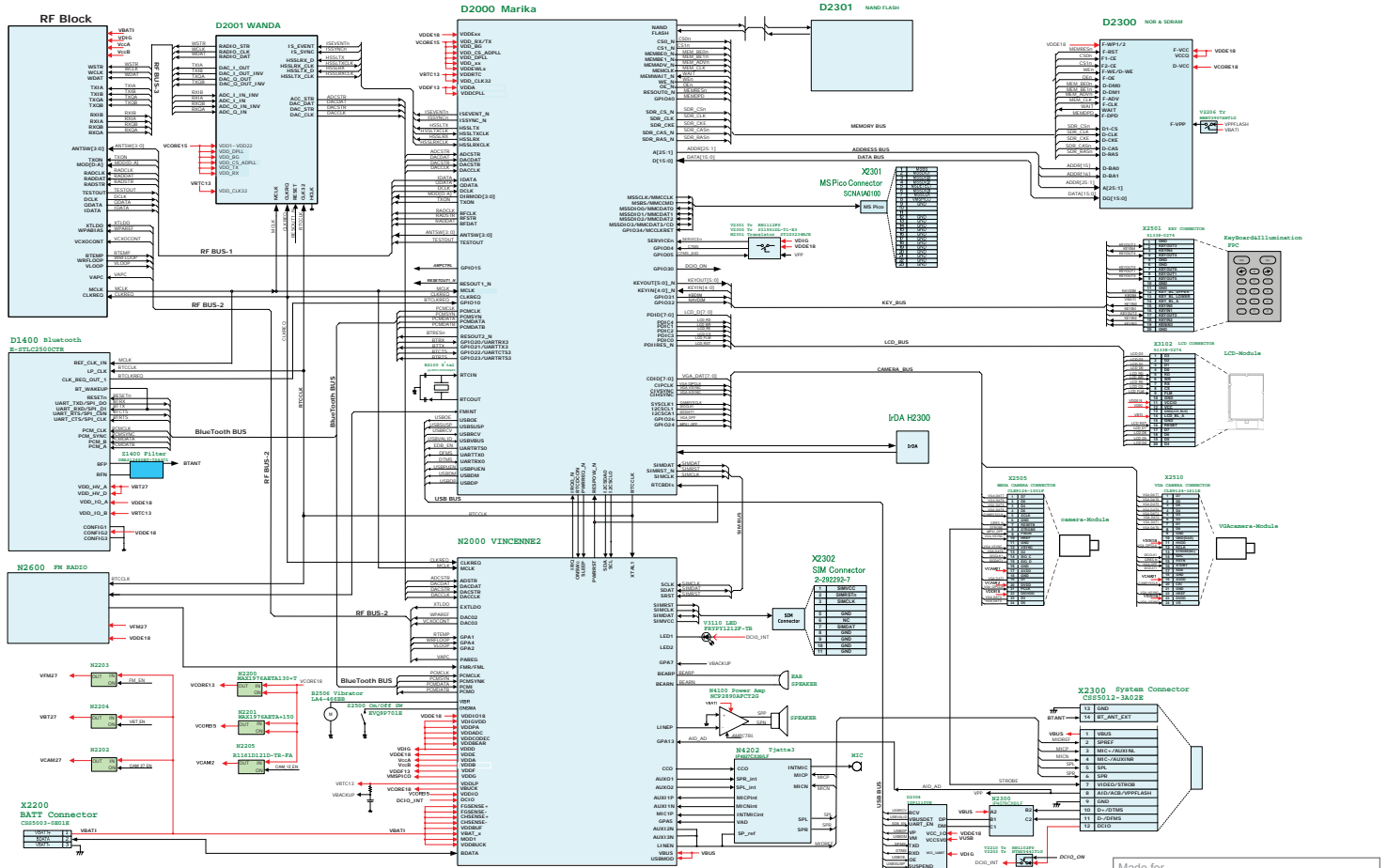

Made for	
Document Nr	Revision

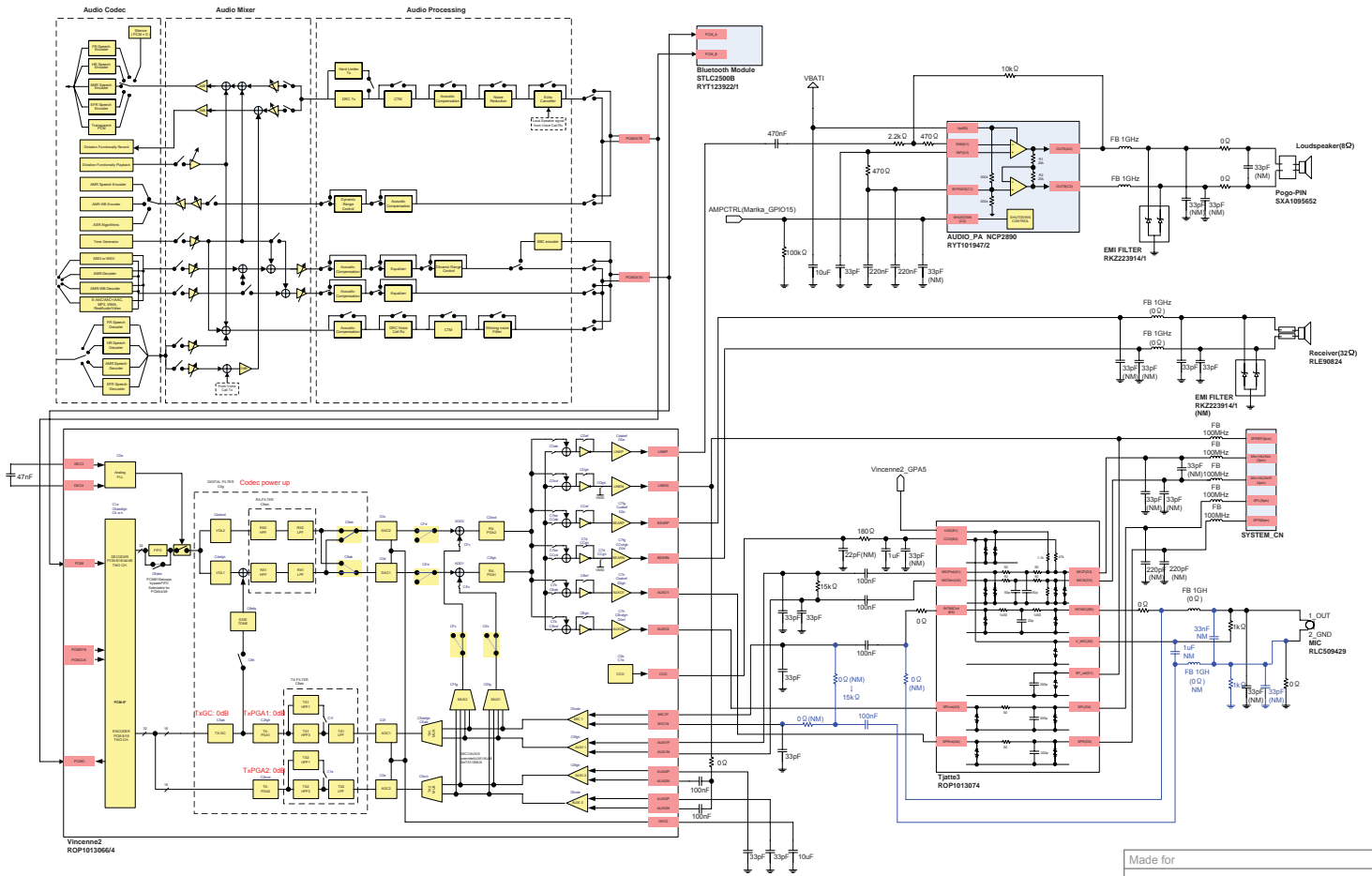

Made for	
Document Nr	Revision

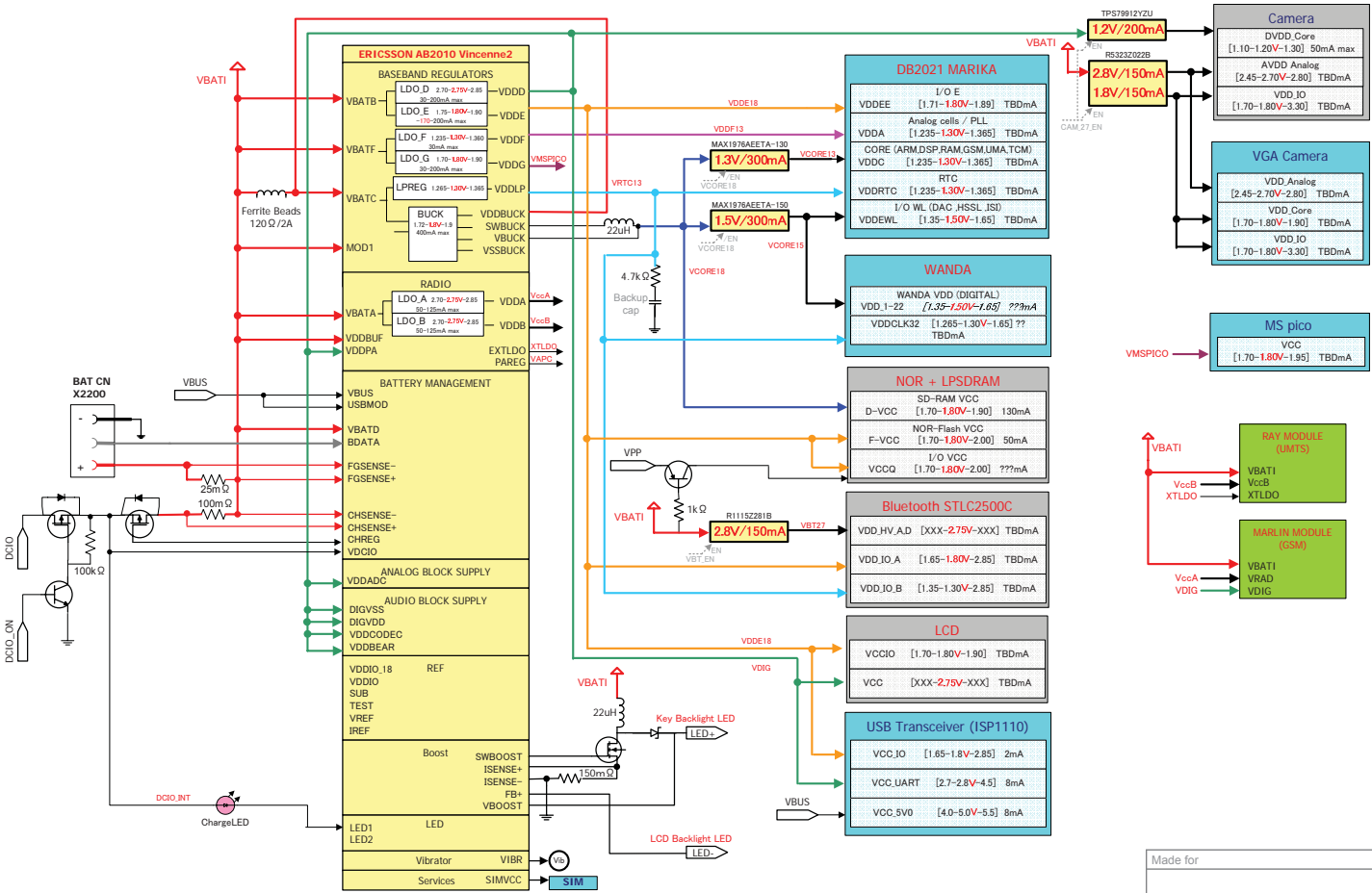

Made for	
Document Nr	Revision

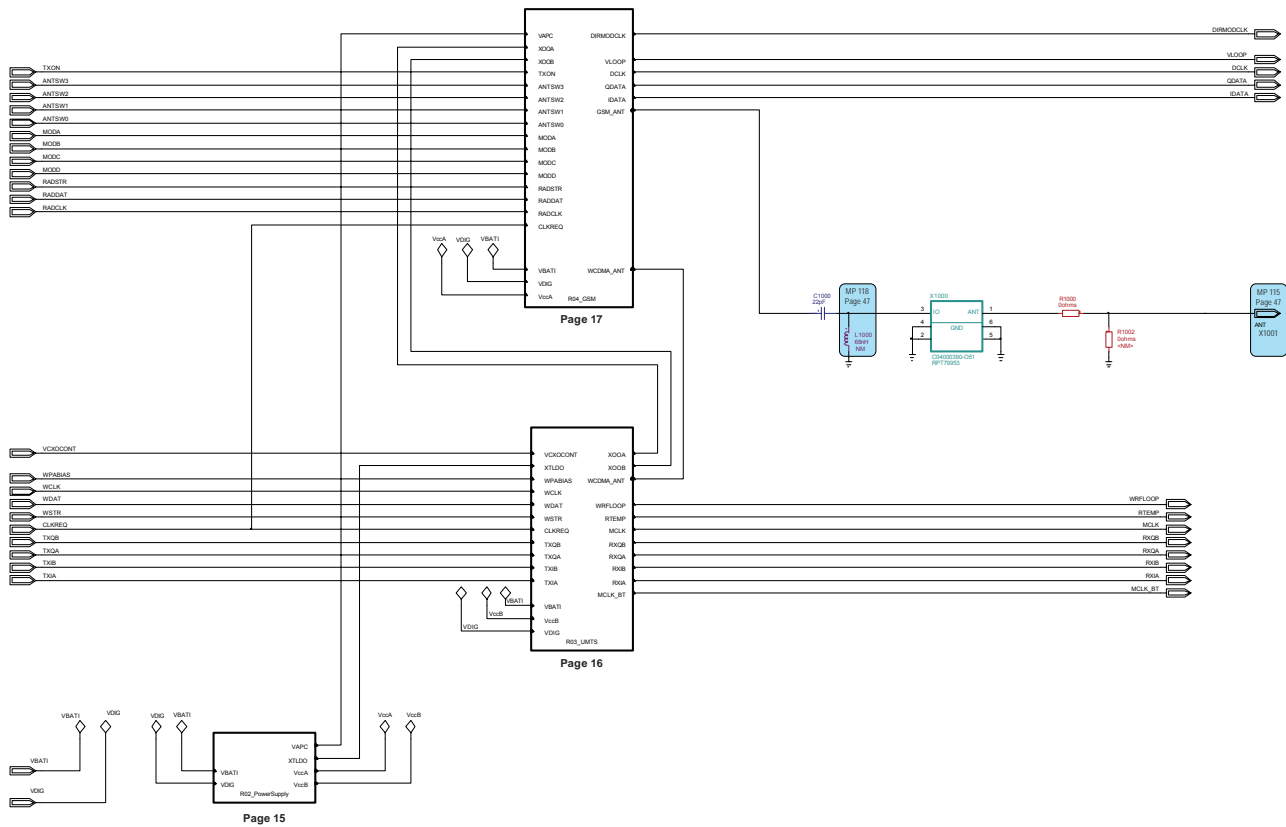

Made for RADIO TOP	
Document Nr 1/1911 - ROA 128 1534/2	Revision A

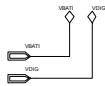
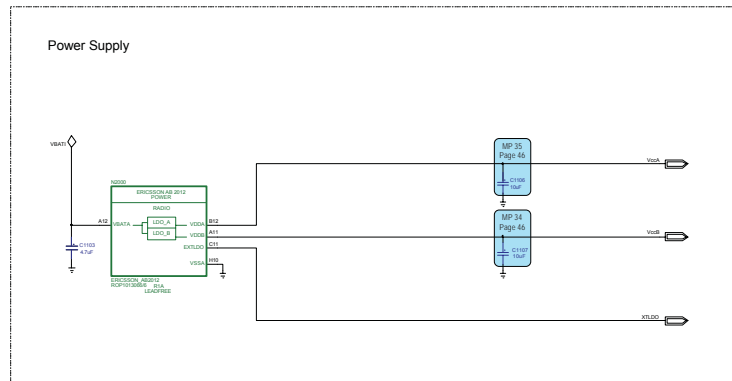
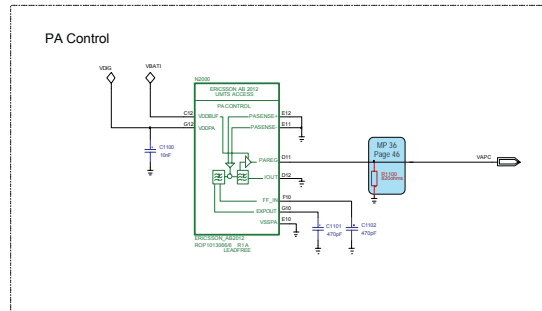

Made for RADIO - Power Supply	
Document Nr 1/1911 - ROA 128 1534/2	Revision A

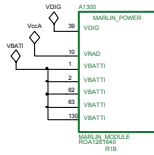
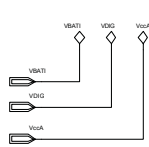
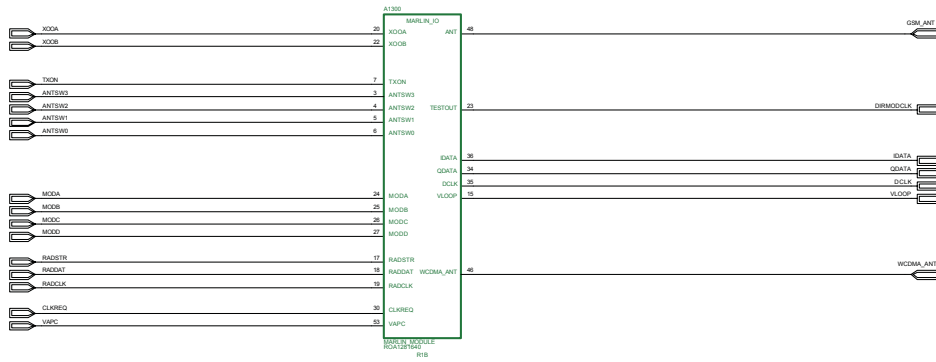

Made for RADIO - GSM	
Document Nr 1/1911 - ROA 128 1534/2	Revision A

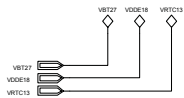
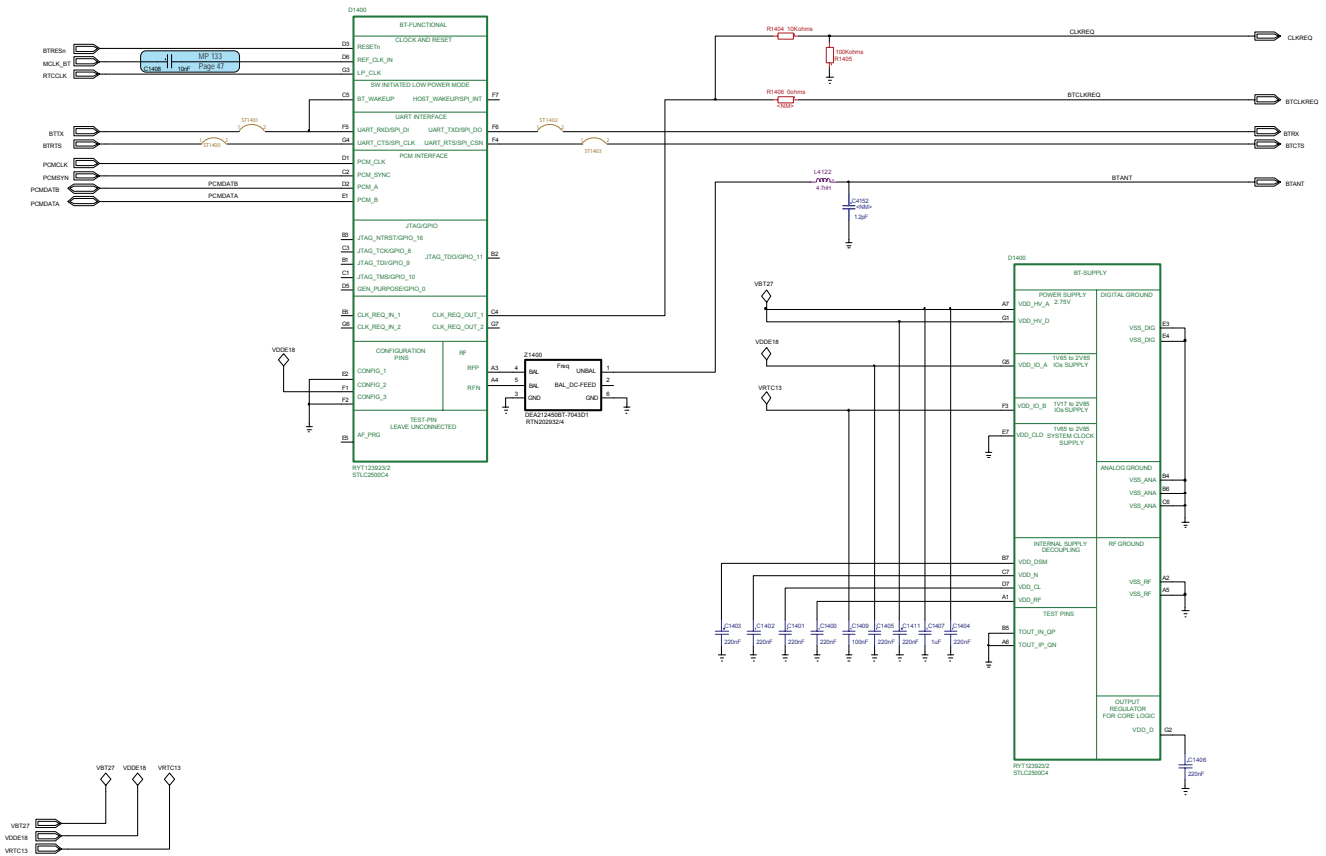

Made for RADIO - Bluetooth	
Document Nr 1/1911 - ROA 128 1534/2	Revision A

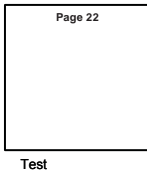
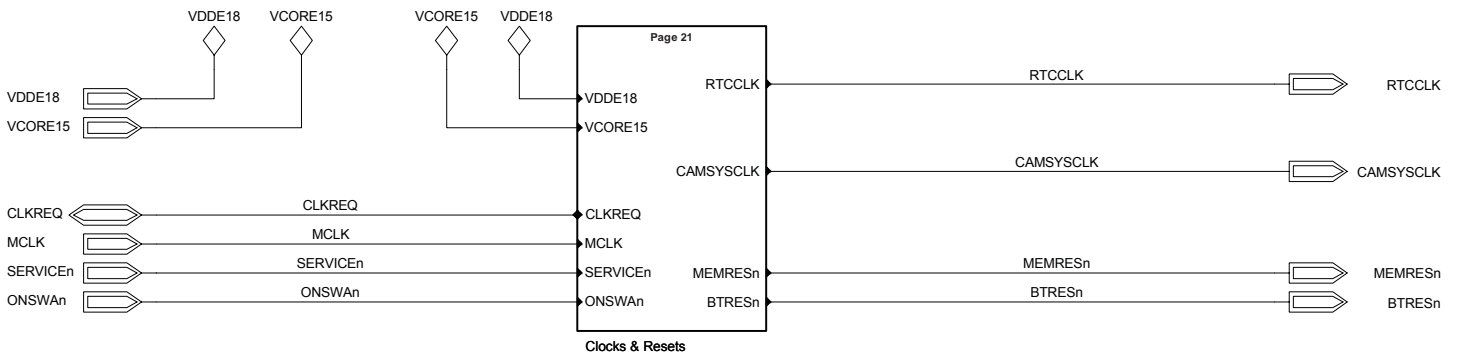

Made for	
BASEBAND - System Control Top	
Document Nr	Revision
2/1911 - ROA 128 1534/2	A

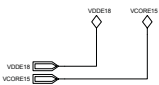
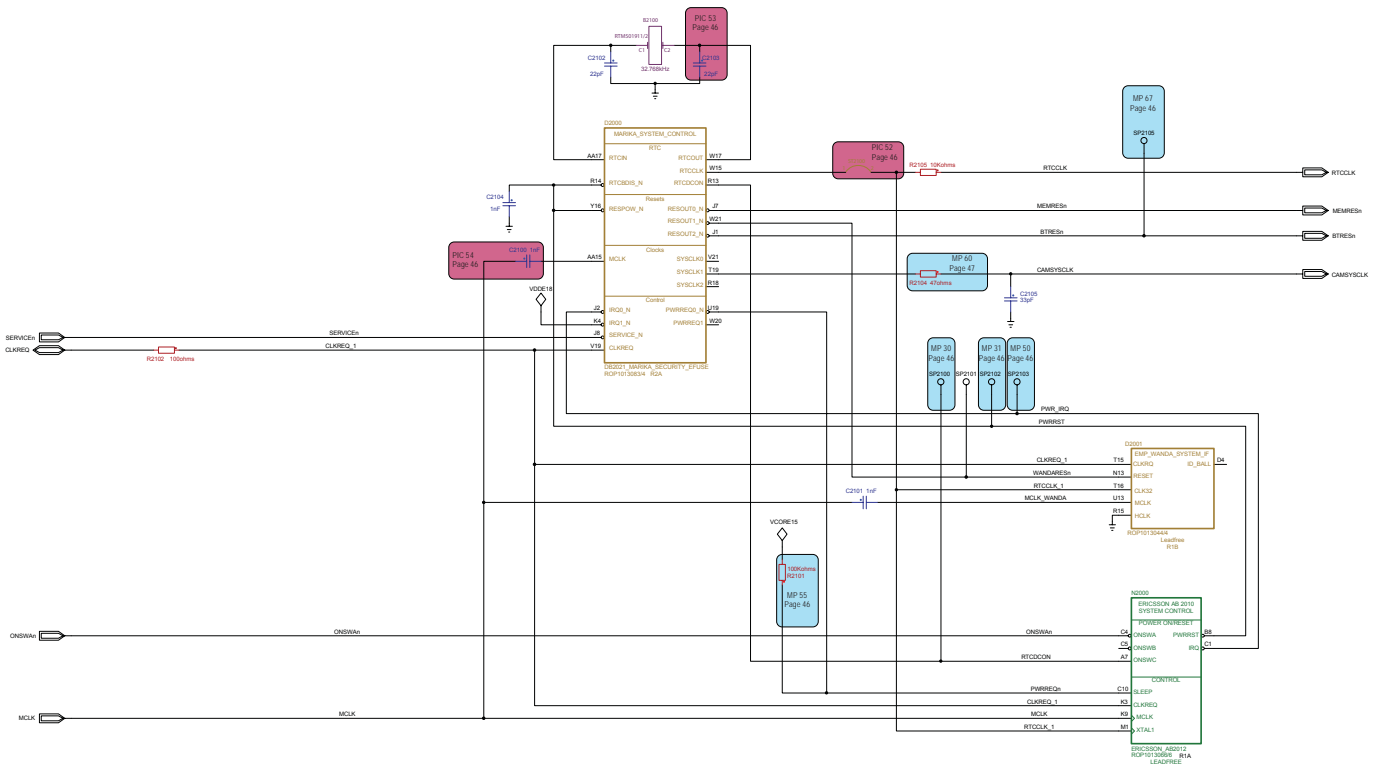

Made for	
BASEBAND - System Control Clocks & Resets	
Document Nr	Revision
2/1911 - ROA 128 1534/2	A

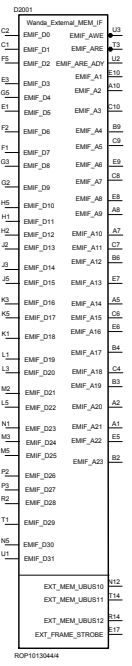
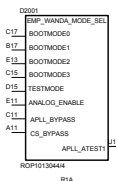
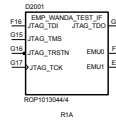
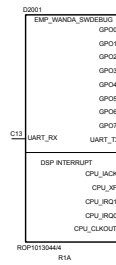
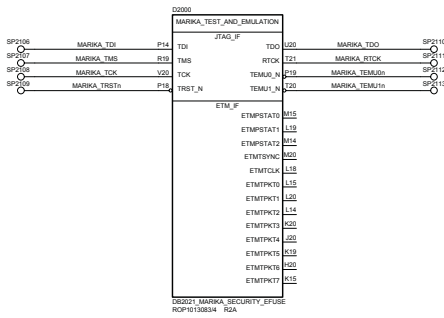

Made for	
BASEBAND - System Control Test	
Document Nr	Revision
2/1911 - ROA 128 1534/2	A

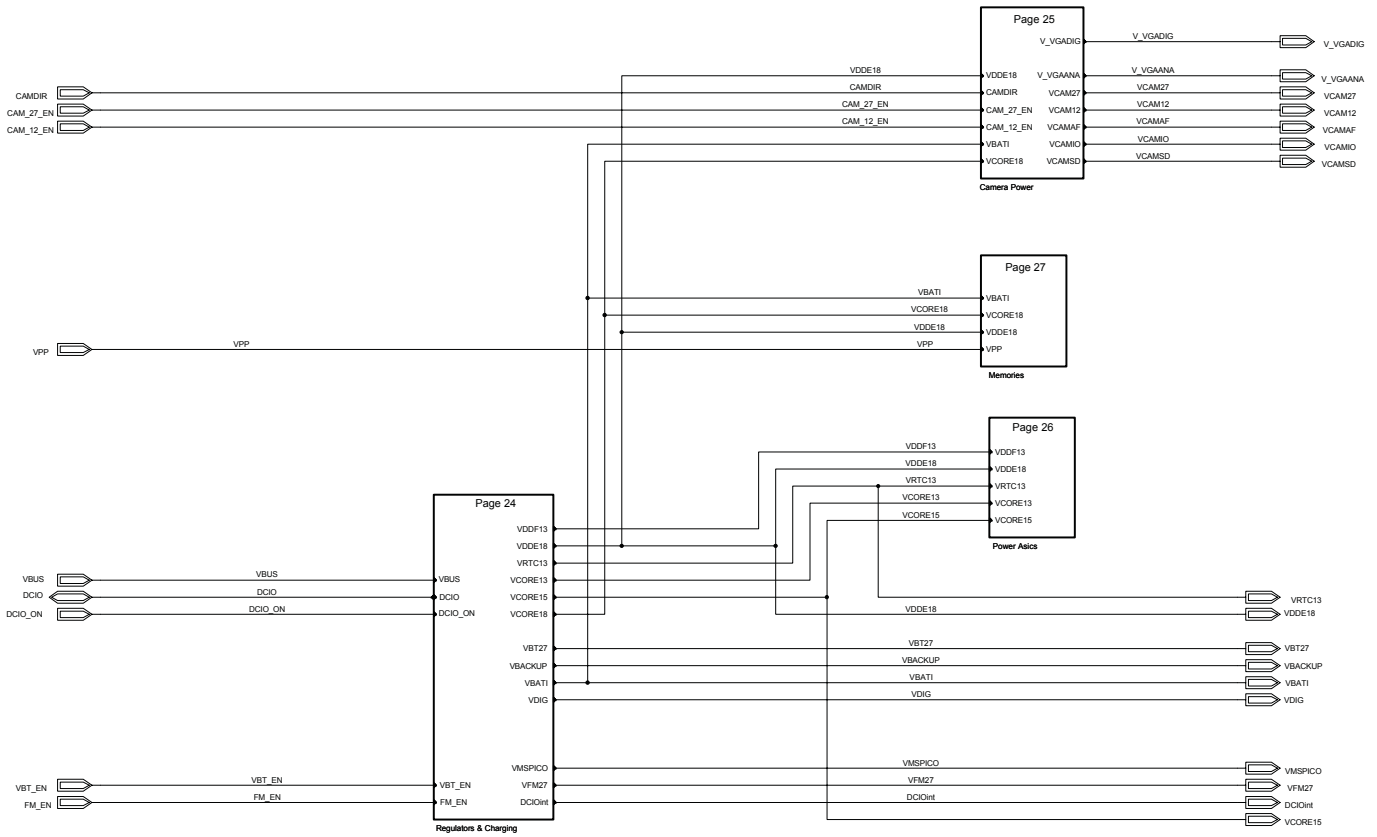

Made for	
BASEBAND - Power Top	
Document Nr	Revision
2/1911 - ROA 128 1534/2	A

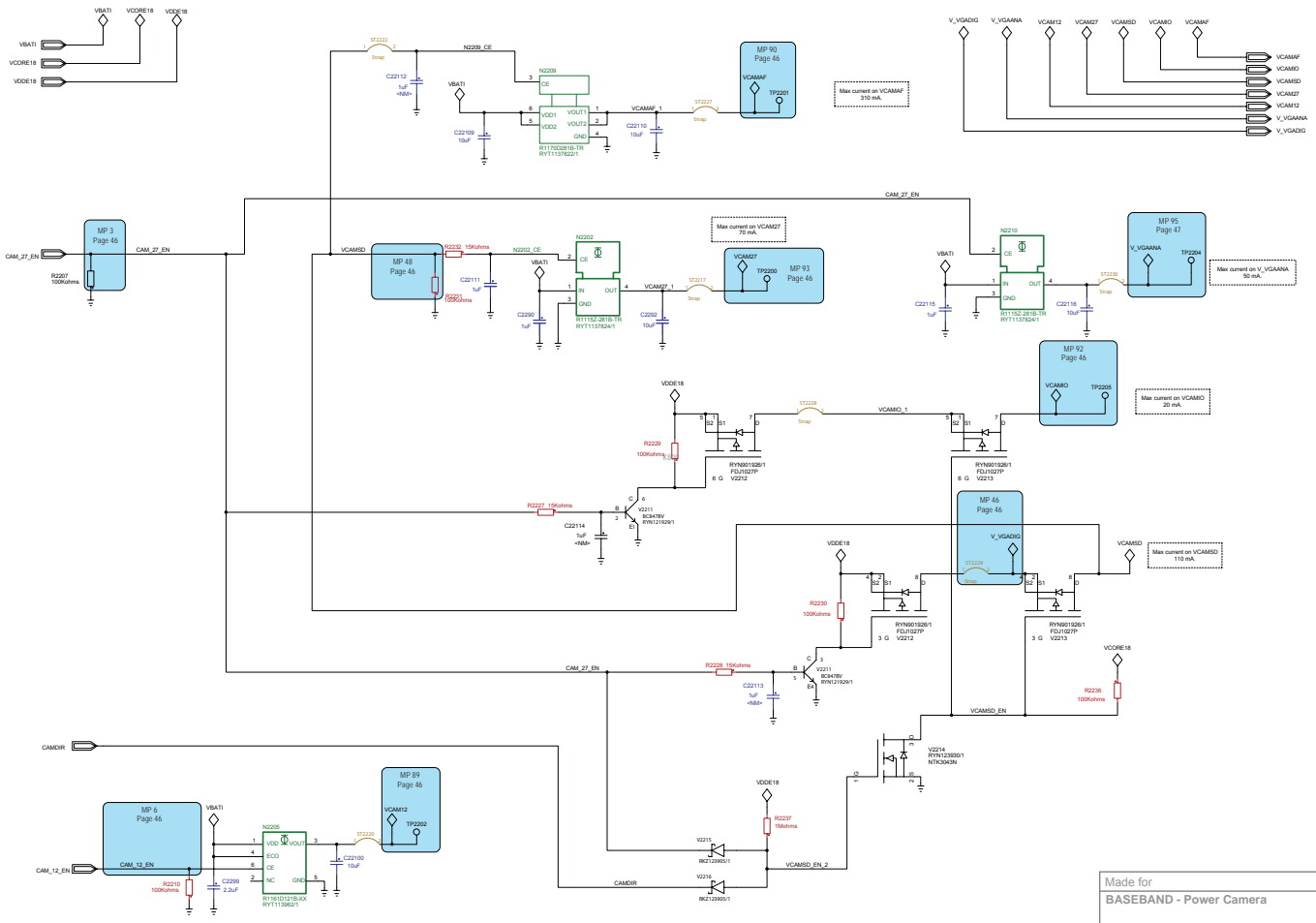

Made for BASEBAND - Power Camera	
Document Nr 2/1911 - ROA 128 1534/2	Revision A

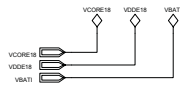
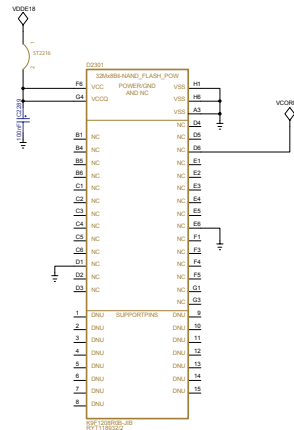
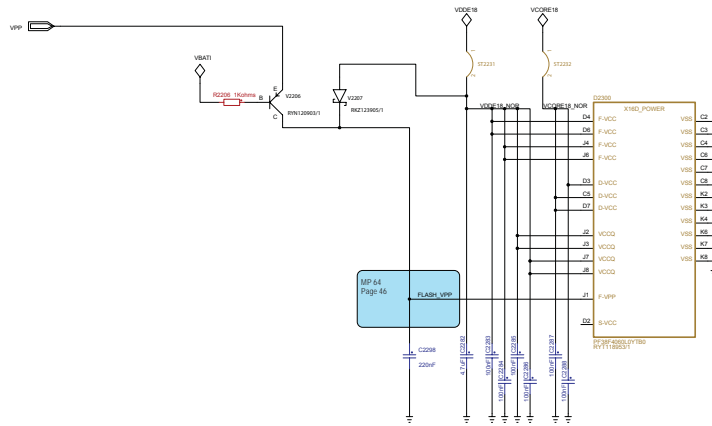

Made for	
BASEBAND - Power Memories	
Document Nr	Revision
2/1911 - ROA 128 1534/2	A

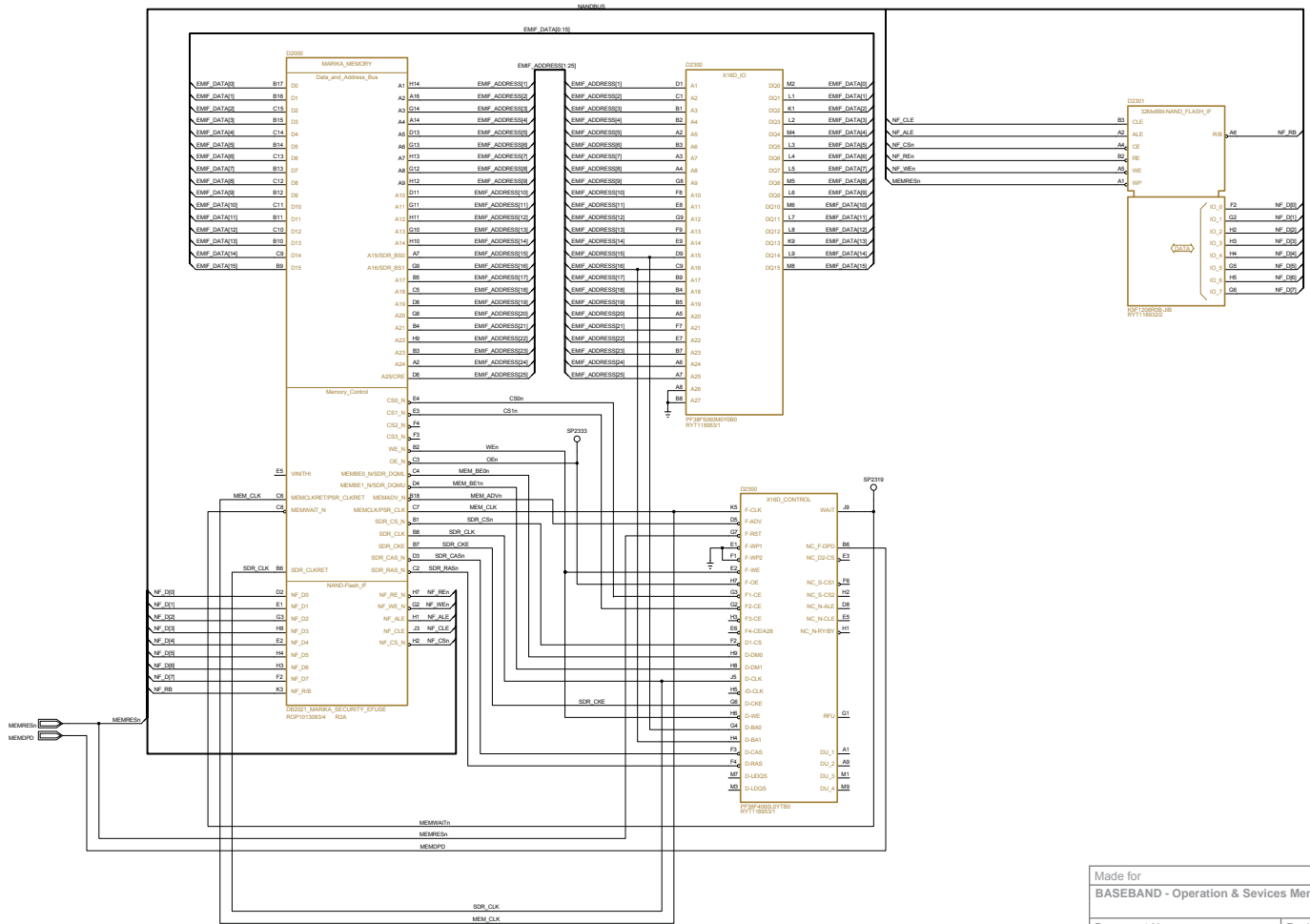

Made for	
BASEBAND - Operation & Services Memories	
Document Nr	Revision
2/1911 - ROA 128 1534/2	A

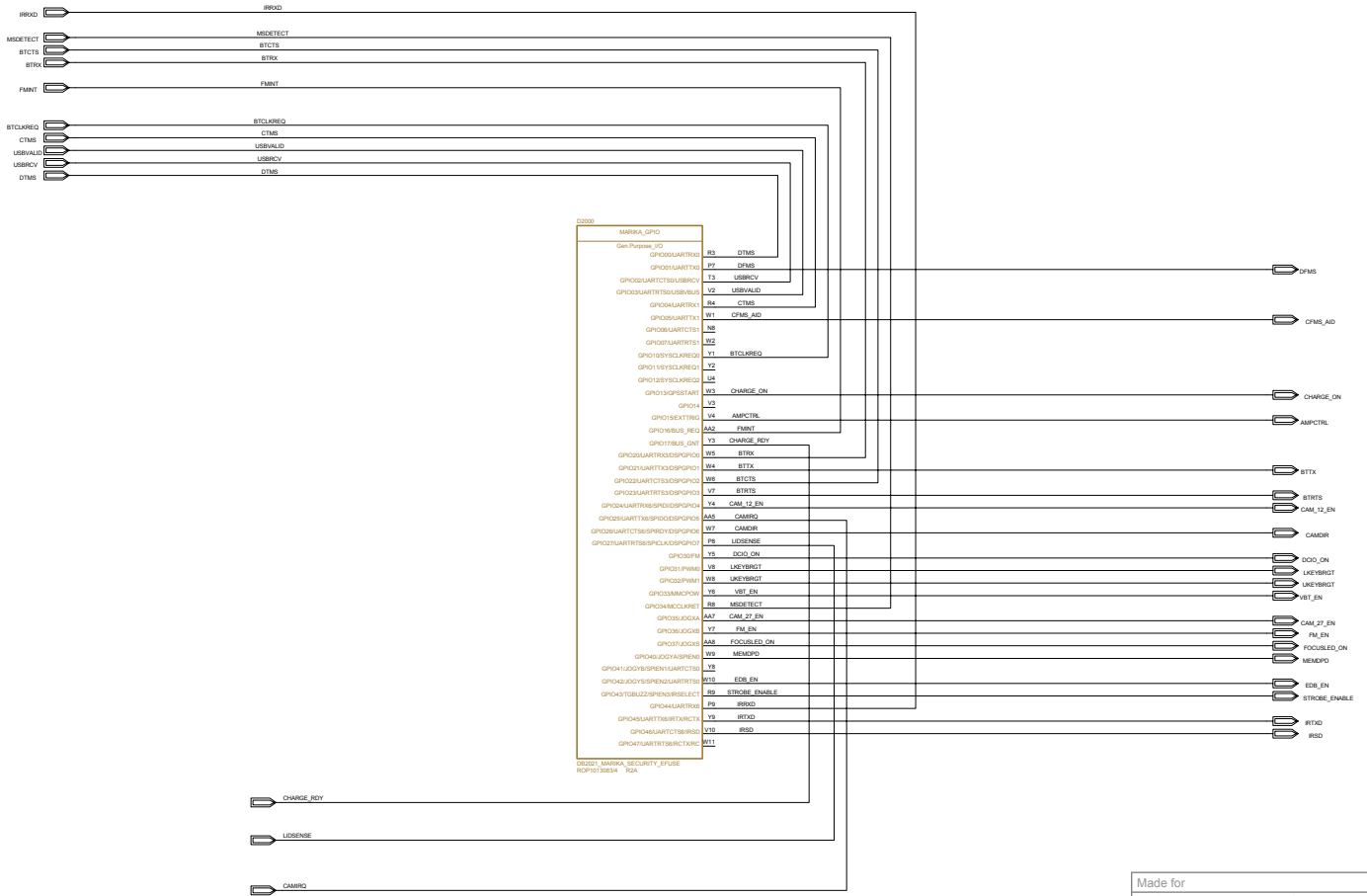

Made for	
BASEBAND - Operation & Services GPIO	
Document Nr	Revision
2/1911 - ROA 128 1534/2	A

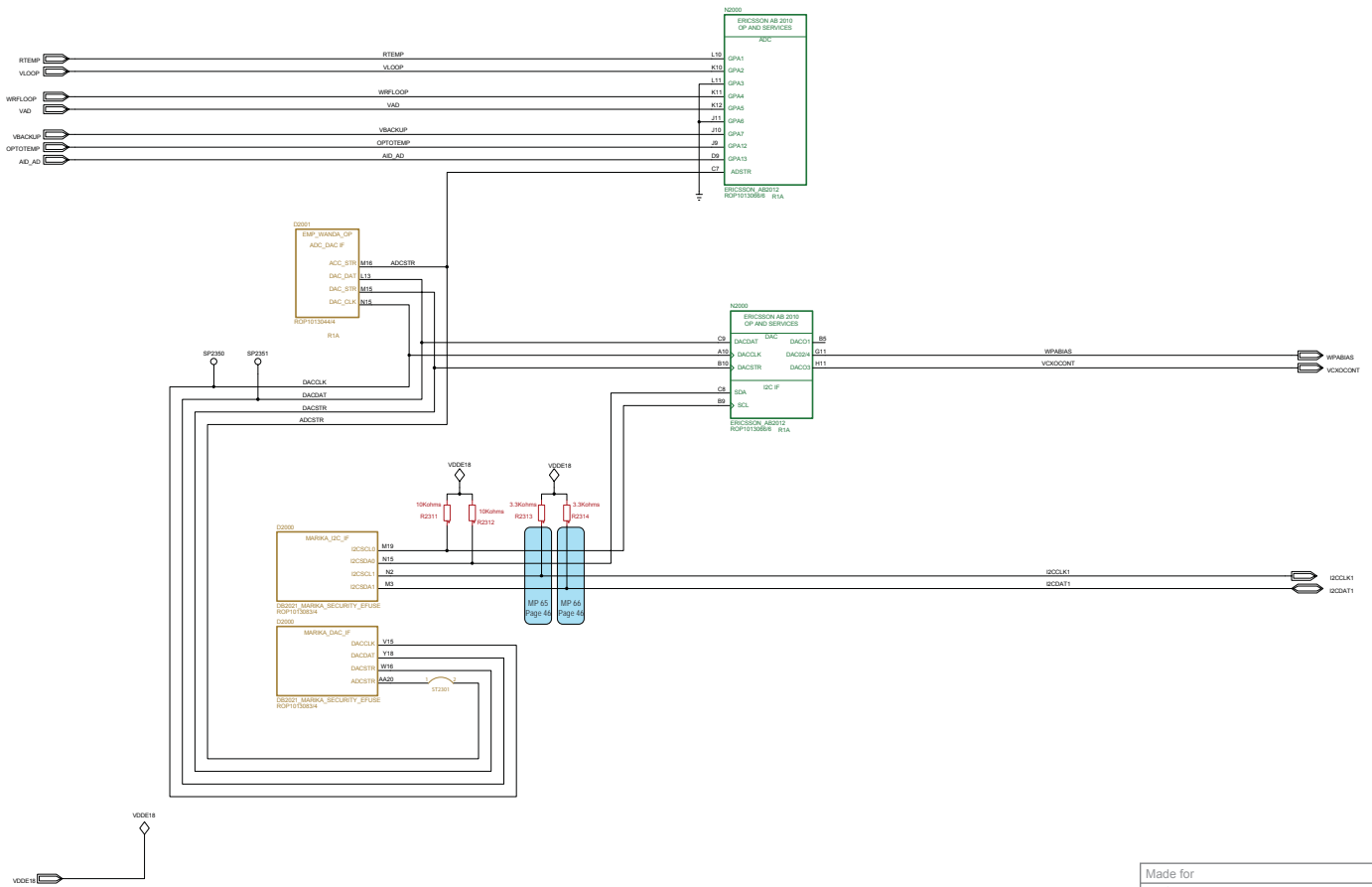

Made for	
BASEBAND Operation & Services ADC & DAC	
Document Nr	Revision
2/1911 - ROA 128 1534/2	A

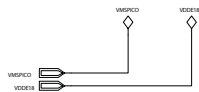
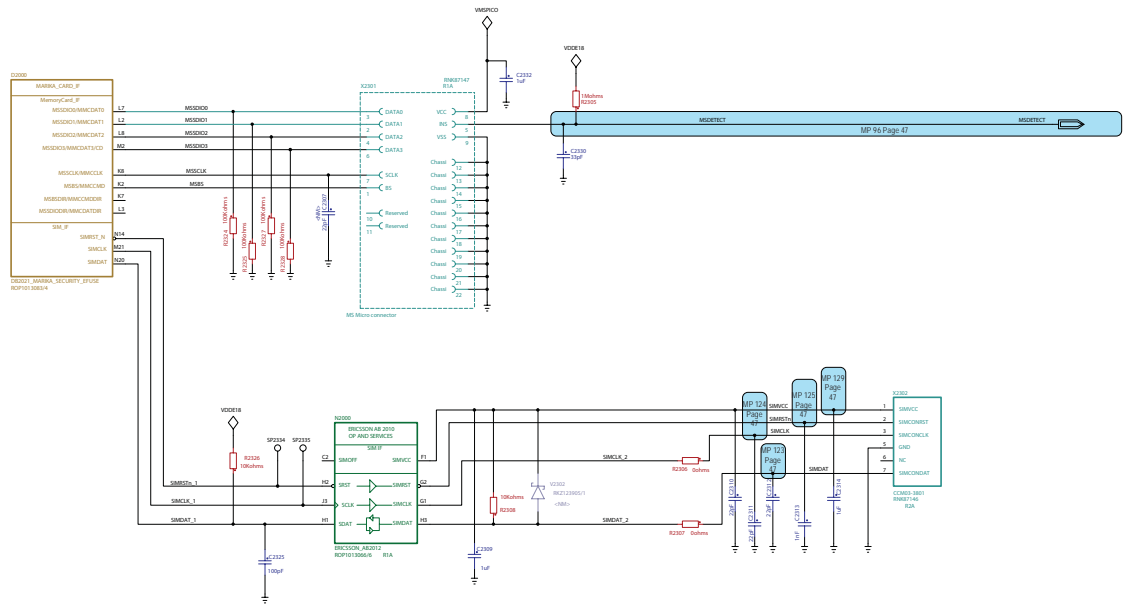

Made for	
BASEBAND Operation & Services MS Pico and SIM	
Document Nr	Revision
2/1911 - ROA 128 1534/2	A

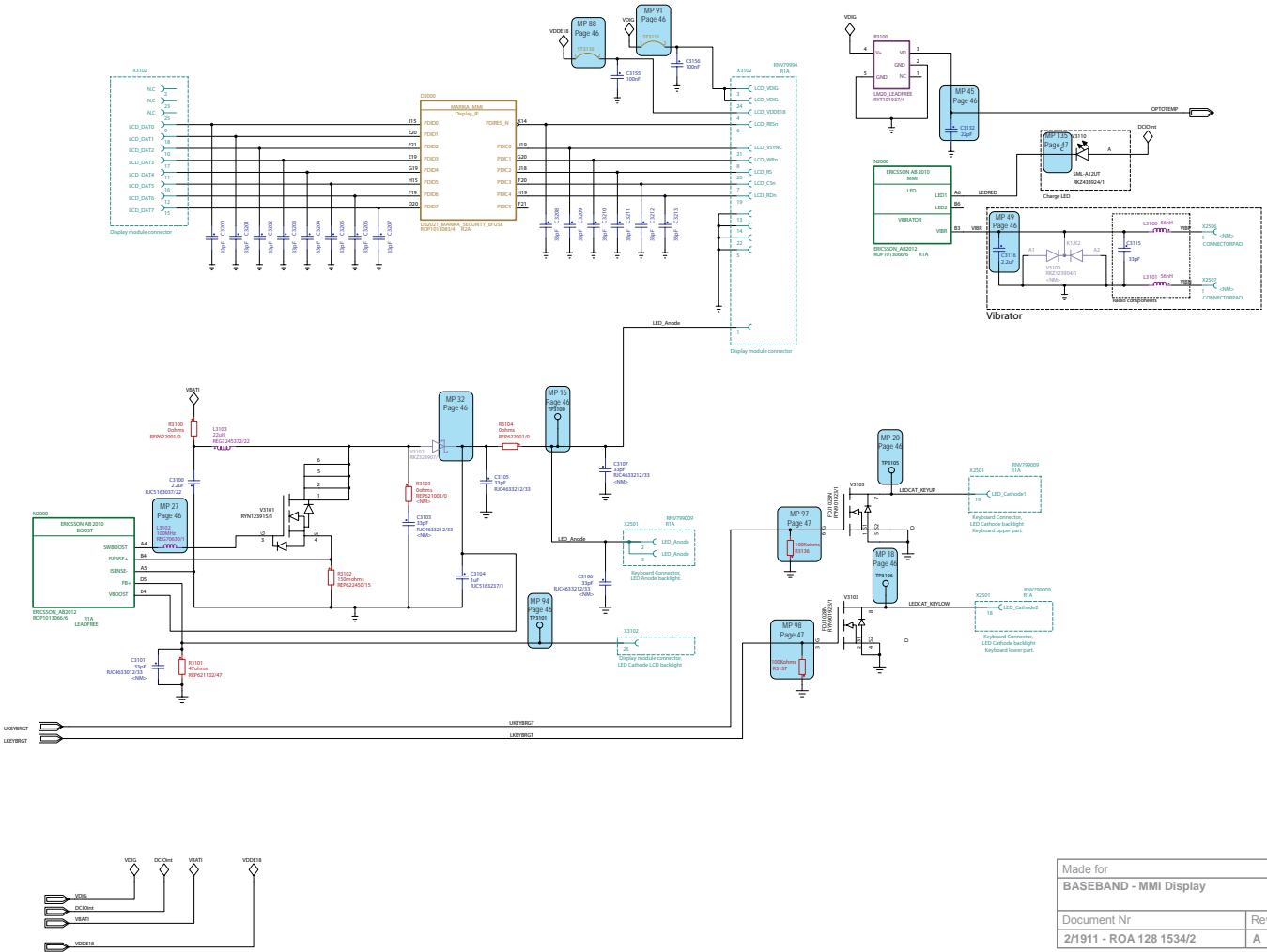

Made for BASEBAND - MMI Display	
Document Nr 2/1911 - ROA 128 1534/2	Revision A

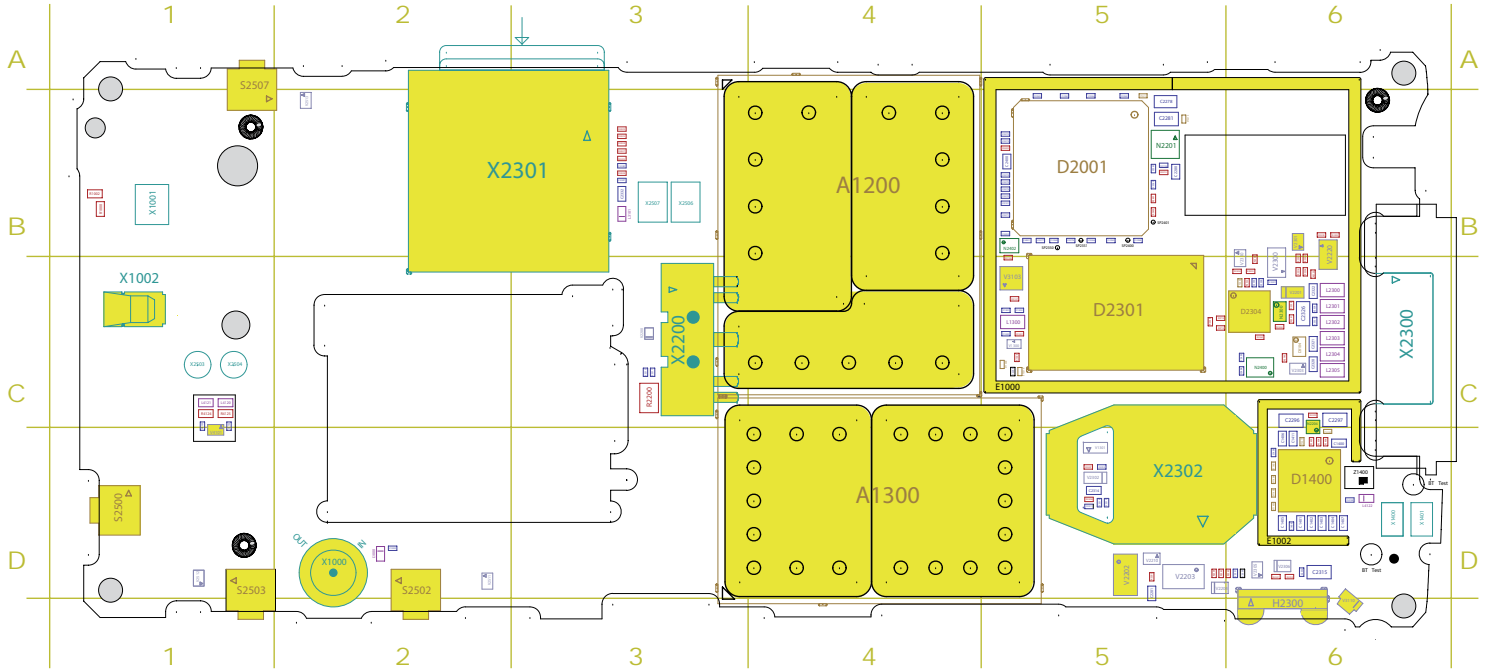

A1300	ROA 128 1112	C4	R	C2212	RJC 463 3011/33	C3	C2277	RJC 516 4016/1	B5	C2321	RJC 516 3026/22	C6	E1002	SXA 109 4043	D8	N2403	RYT 109 914/1	C5	R2304	REP 621 002/47	C4	R2350	REP 621 005/22	C6	V2300	RYN 901 918/2	C6	
A1300	ROA 128 1640	D4	R	C2360	RJC 516 4016/1	B5	C2178	REV 501 10120/1	B5	C2322	RJC 516 3026/22	C6	H2300	RKZ 923 919/1	E1	R1000	REP 622 001/0	B2	R2305	REP 621 006/1	B3	R2400	REP 621 105/43	B5	V2301	RYN 121 931/1	B6	R
C1000	RJC 463 3012/22	D2	R	C2261	RJC 516 4016/1	B5	C2279	RJC 516 4016/1	B5	C2326	RJC 516 3537/1	C6	L1000	REG 724 55 410/98	D2	R1003	REP 622 001/0	B2	R2306	REP 621 001/0	D5	R3136	REP 621 106/1	C5	V2303	RKZ 223 914/1	C6	R
C1300	RJC 516 4016/1	C5	C2262	RJC 516 4016/1	B5	C2280	RJC 516 3027/1	B5	C2327	RJC 516 3514/1	C6	L2300	REG 706 05/19	C6	R1301	REP 621 002/1	C5	R2307	REP 621 001/0	D5	R3137	REP 621 106/1	C5	V2305	RKZ 223 914/1	D6	R	
C1400	RJC 516 3026/22	D6	C2263	RJC 516 4016/1	B5	C2281	RJC 516 3037/47	B5	C2328	RJC 516 3514/1	C6	L3301	REG 706 05/19	C6	R1304	REP 621 104/39	C5	R2309	REP 621 002/33	D5	R4124	REP 622 001/0	C1	V2310	RYN 121 916/2	C6	R	
C1401	RJC 516 3026/22	D6	C2264	RJC 516 4016/1	B5	C2289	RJC 516 4016/1	C4	C2330	RJC 463 3012/33	B3	L3302	REG 706 05/19	C6	R1404	REP 621 105/1	D6	R2310	REP 621 006/1	D6	R4125	REP 622 001/0	C1	V2311	RKZ 223 914/1	D2	R	
C1402	RJC 516 3026/22	D6	C2265	RJC 516 4016/1	B5	C2296	RJC 516 3037/47	C6	C2332	RJC 516 3027/1	B3	L3303	REG 706 05/19	C6	R1405	REP 621 104/1	D6	R2316	REP 621 105/47	D1	S2500	RMD 101 16/4	D1	V2312	RKZ 223 914/1	D1	R	
C1403	RJC 516 3026/22	D6	C2266	RJC 516 4016/1	B5	C2297	RJC 516 3037/22	C6	C2400	RJC 516 3526/1	B5	L3304	REG 706 05/19	C6	R2200	REP 624 650/025	C3	R2321	REP 621 006/1	D6	S2502	RMD 101 16/4	D1	V2313	RKZ 223 914/1	B2	R	
C1404	RJC 516 3026/22	D6	C2267	RJC 516 4016/1	B5	C2300	RJC 516 4016/1	C6	C2401	RJC 516 4016/1	B5	L3305	REG 706 05/19	C6	R2202	REP 621 006/1	D5	R2322	REP 621 106/1	C6	S2503	RMD 101 16/4	D1	V2315	RYN 901 923/1	C5	R	
C1405	RJC 516 3026/22	D6	C2268	RJC 516 4016/1	B5	C2301	RJC 516 4016/1	C6	C2402	RJC 516 4016/1	B5	L3301	REG 724 9342/56	B3	R2209	REP 621 006/1	C6	R2324	REP 621 006/1	B3	S2507	RMD 101 16/4	B1	V3110	RKZ 433 924/1	E4	R	
C1406	RJC 516 3026/22	D6	C2269	RJC 516 4016/1	B5	C2302	RJC 516 4016/1	C6	C2403	RJC 516 4016/1	C6	L4120	REG 724 55 42/56/1	C1	R2213	REP 621 004/47	B5	R2325	REP 621 006/1	B3	V4101	RKZ 223 914/1	D1	V3101	RYN 121 933/2	C5	R	
C1407	RJC 516 3027/1	D6	C2270	RJC 516 4016/1	B5	C2310	RJC 463 3012/22	D5	C2404	RJC 516 4016/1	C6	L4121	REG 724 55 42/56/1	C1	R2233	REP 621 006/1	B6	R2327	REP 621 006/1	B3	V1301	RYN 121 933/2	C5	X1000	RPT 799 51	D1	R	
C1408	RJC 516 3026/22	D6	C2271	RJC 516 4016/1	B5	C2311	RJC 463 3012/22	D5	O1400	RYT 123 923/2	B6	L4122	REG 724 9301/47	D6	R2234	REP 621 006/22	C6	R2328	REP 621 006/1	B3	V2200	RKZ 123 911/1	C3	X1001	RPT 799 51	B1	R	
C1409	RJC 516 4016/1	D6	C2272	RJC 516 4016/1	B5	C2312	RJC 463 3012/22	D5	O3001	RDP 101 3044/4	B5	N2201	RYT 113 781/2	B5	R2235	REP 621 006/1	B6	R2338	REP 621 006/1	C5	V2201	RKZ 123 901/1	C6	X1002	RPT 799 51	C1	R	
C1411	RJC 516 3026/22	D6	C2273	RJC 516 4016/1	B5	C2313	RJC 516 3014/1	D5	O3001	RYT 118 932/2	C5	N2204	RYT 113 782/41	D6	R2300	REP 621 006/1	C6	R2341	REP 621 006/47	C6	V2202	RYN 122 484/2	D5	X2200	SND 106 22	C1	R	
C2101	RJC 516 3514/1	B5	C2274	RJC 516 4016/1	B5	C2314	RJC 516 3027/1	D5	O3204	RYT 109 912/1	C6	N2300	RKZ 923 923/1	C6	R2301	REP 621 006/1	C6	R2342	REP 621 002/33	D6	V2203	RYN 122 484/2	D5	X2201	RNK 871 47/1	B2	R	
C2106	RJC 516 4016/1	B5	C2275	RJC 516 4016/1	B5	C2315	RJC 516 3037/47	D4	O3104	RYT 109 914/1	C6	N2400	RYT 113 995/1	C6	R2302	REP 621 103/56	C6	R2343	REP 621 002/33	D6	V2204	RKZ 123 915/0	D5	X2202	RNK 871 46	D5	R	
C2211	RJC 463 3012/22	C3	C2276	RJC 516 4016/1	B5	C2320	RJC 516 3026/22	C6	E1000	SXA 109 5997	C5	N2402	RYT 109 914/1	B5	R2303	REP 621 004/47	C6	R2344	REP 621 006/47	C6	V2220	RYN 123 919/1	C6	X2400	R7N 202 932/4	D6	R	

R - Replaceable
See Appendix for
more information.

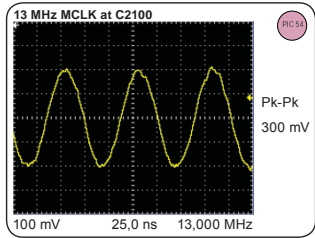
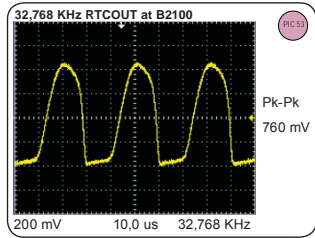
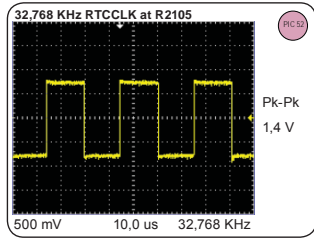
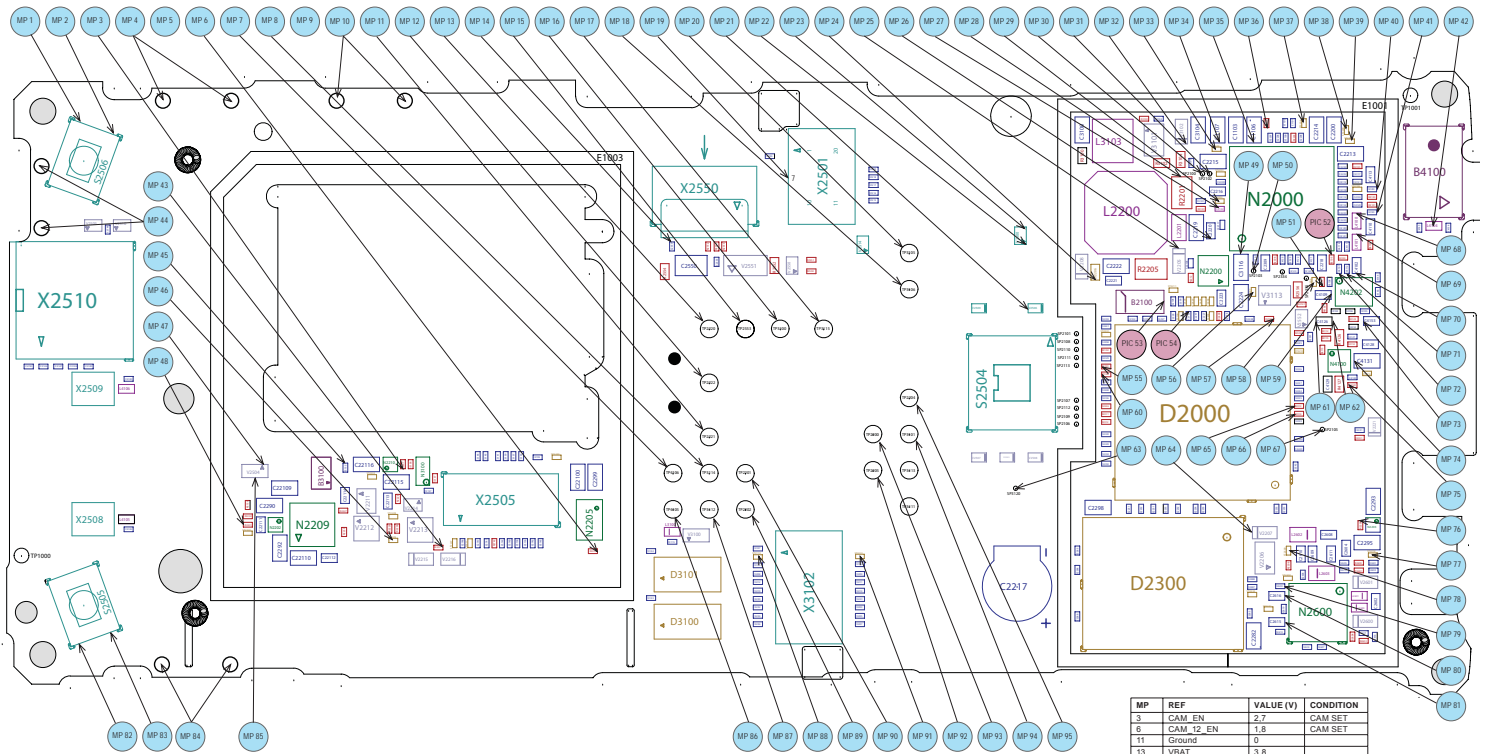

MP	REF	VALUE (V)	CONDITION
3	CAM_EN	2.7	CAM SET
6	CAM_T2_EN	1.8	CAM SET
11	Ground	0	
13	VBAT	3.8	
24	VCORE18	1.8	
26	VDOBURUCK	3.8	
28	VDDF13	1.3	
34	VccB	2.75	
35	VccA	2.75	
37	VDOE18	1.8	
38	VBATI	3.8	
39	VDIG	2.75	
43	VCAMSD_EN 2	1.8	CAM SET
46	V_VGADIG	1.8	CAM SET
48	VCAMSD	1.8	CAM SET
56	VCORE13	1.3	
58	VRTC13	1.3	
77	VFM27	2.7	FM SET
89	VCAM12	1.2	CAM SET
90	VCAMAF		CAM SET
92	VCAM0	1.8	CAM SET
95	V_VGANA	2.7	CAM SET
100	VCORE15	1.5	
137	VBT27	2.7	BT SET

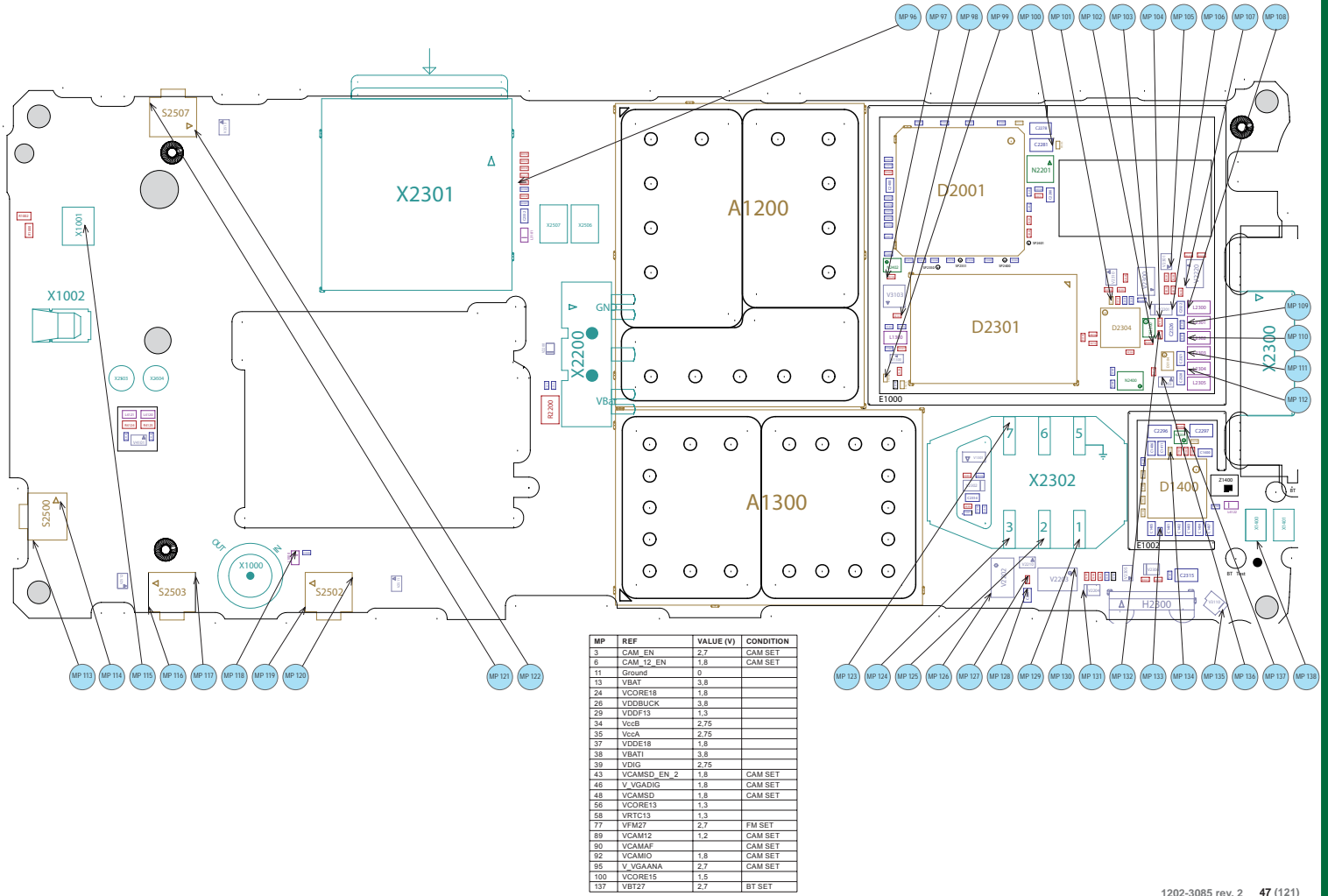

General

The purpose of this document is to indicate the electrical level repair actions associated with the different failure symptoms.

For symptoms that have multiple repair actions, the repair actions are listed in order of their probability of creating a successful repair. The first action has the highest probability, and subsequent actions have lower probabilities. The intention is for the repair technician to implement the first repair action and then retest the phone. If the phone continues to fail the same test, then the technician should continue to the second repair action. If the phone continues to fail the same test after all of the repair actions are exhausted, then the phone will be considered not repairable at this level. This document should be used only after the actions from the Mechanical Trouble Shooting Guide have been exhausted for the specific symptom.

Voltage, current, and resistance information is provided for some symptoms to enable faster repairs. Perform current measurements using a dummy battery and power supply with digital current display. The phone should be fully assembled. The phone should be fully assembled. Perform voltage and resistance measurements with a multimeter. Purchasing this equipment and performing these measurements is optional but recommended.

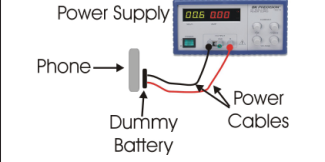
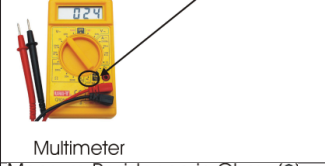
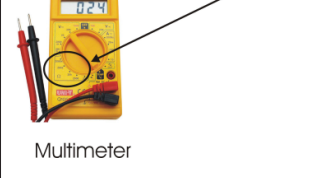
<p>Measure Current in Milliamps (mA)</p> 	<p>Perform current measurements using a dummy battery and power supply with digital current display. The phone should be fully assembled.</p>
<p>Measure Diode Voltage (VDC →→)</p> 	<p>Perform voltage measurements with a multimeter.</p>
<p>Measure Resistance in Ohms (Ω)</p> 	<p>Perform resistance measurements with a multimeter.</p>

Repair Actions for Manual Test Failures

Failure	Failure Symptom	Repair Action
Power On / Off	Current draw greater than 300 mAmps	<ul style="list-style-type: none"> N2000 C22109 K790 ONLY – N1100 K800/K810 ONLY – A1200 – Approved Centers Only C22109
	Current draw when powered off	<ul style="list-style-type: none"> K790 ONLY – N1100 K800/K810 ONLY – A1200 – Approved Centers Only A1300 – Approved Centers Only
	Hangs at gray display. Constant vibration. Will not power off.	<ul style="list-style-type: none"> B2100
	Draws current when pushing power key, returns to zero	<ul style="list-style-type: none"> Run pre-configuration using EMMA N2000 D2301 N2200
	Powers on by itself after installing battery. Will not power off.	<ul style="list-style-type: none"> Replace S2500 if damaged V2504
	No response when pushing power key (no current change)	<ul style="list-style-type: none"> Replace S2500 if damaged
	Phone hang when Bluetooth is turned on. If you can't recreate the phone hang problem, you should check that Bluetooth is switched on to eliminate this possibility	<ul style="list-style-type: none"> D1400
	Permanent phone hangs at start up or in standby	<ul style="list-style-type: none"> K790 ONLY (ROA revision R3A and R3B only) – Replace R1404 and R1405 Replace X2200 if damaged
	Other symptoms	<ul style="list-style-type: none"> N2000, D2301
	Software Flash	USB icon does not flash Error message "USB device not recognized"
USB icon flashes Progress indicator appears with red X		<ul style="list-style-type: none"> V2301
No response from computer or phone Measure V2201 with positive lead on the Anode. VDC should equal 0.15 to 0.19.		<ul style="list-style-type: none"> If VDC is outside of range, then replace V2201 V2220
Other symptoms		<ul style="list-style-type: none"> D2301, D2304

Failure	Failure Symptom	Repair Action
Charging	Charging from power outlet	<ul style="list-style-type: none"> V2202 N2000
	Charging from computer via USB Measure V2201 with positive lead on the Anode. VDC should equal 0.15 to 0.19.	<ul style="list-style-type: none"> If VDC is outside of range, then replace V2201 V2220
Charging indicator (RED LED)		<ul style="list-style-type: none"> V3110
Hands-Free connection (PHF)		<ul style="list-style-type: none"> N4202 N2000
SIM		<ul style="list-style-type: none"> Replace X2302 if damaged N2000
Display		<ul style="list-style-type: none"> Replace X3102 if damaged Replace X3102 if damaged Replace X2501 if damaged If VDC is outside of range, then replace V3102
Display / Keypad LED Illumination	Display and keys work, but they are dark. Measure V3102 with the Positive (red) probe on the anode = 0.16 to 0.19	<ul style="list-style-type: none"> V3101 N2000 R3101
	Display light works, but keys are dark	<ul style="list-style-type: none"> V3103
Keypad Keys		<ul style="list-style-type: none"> Replace X2501 if damaged
Volume Down/Up Keys		<ul style="list-style-type: none"> Replace S2502, S2503 if damaged
Camera Key		<ul style="list-style-type: none"> Replace X2501 if damaged
On/Off key		<ul style="list-style-type: none"> Replace S2500 if damaged
Gaming (A and B) Keys		<ul style="list-style-type: none"> Replace S2505, S2506 if damaged
Media Player Key		<ul style="list-style-type: none"> Replace S2507 if damaged Replace S2504 if damaged
Navigation Key (Joystick)		<ul style="list-style-type: none"> V2500 N2000
Vibrator		<ul style="list-style-type: none"> N2000
Earphone (Speaker, Receiver)		<ul style="list-style-type: none"> N2000 V4101
Polyphonic Speaker (Alert, Speakerphone)		<ul style="list-style-type: none"> N4100
Backup Battery		<ul style="list-style-type: none"> N2000 C2217 B4100
Microphone		<ul style="list-style-type: none"> N4202 N2000 B2100
Real Time Clock		<ul style="list-style-type: none"> Replace X2505 if damaged
Camera (Large, Rear)		<ul style="list-style-type: none"> N2202 N3100 (Can't take picture) K800/K810 ONLY. K790 does not include this camera.
VGA Camera (Small, Front)		<ul style="list-style-type: none"> Replace X2510 if damaged D3100, D3101 N2210

Failure	Failure Symptom	Repair Action
Camera Flash		<ul style="list-style-type: none"> Replace X2550 if damaged V3113 V2552
Camera Lens Cover Sensor		<ul style="list-style-type: none"> Replace X2550 if damaged V2500 H2300
IR		<ul style="list-style-type: none"> N2204
Bluetooth		<ul style="list-style-type: none"> N2000 D1400
FM Radio		<ul style="list-style-type: none"> N2203 N2600 N2000
Memory Card		<ul style="list-style-type: none"> Replace X2301 if damaged

Repair Actions for Go/No Go Test Failures

Failure	Repair Action
Fails any part of Go/No Go testing	<ul style="list-style-type: none"> run the calibration routine
Fails Go/No Go test, but passes calibration	<ul style="list-style-type: none"> replace the antenna Replace X1002 if damaged rerun the phone through Go/No Go testing
Fails Go/No Go test after passing calibration	<ul style="list-style-type: none"> change X1000 and retest

Repair Actions for Calibration Failures

K790

Failure	Repair Action
Fails any part of the calibration routine	<ul style="list-style-type: none"> Replace X1002 if damaged Replace X1000 if damaged N1100

K800

Failure	Repair Action
Fails any part of the calibration routine	<ul style="list-style-type: none"> Replace X1002 if damaged Replace X1000 if damaged A1200 UMTS – Approved Centers Only A1300 GSM – Approved Centers Only

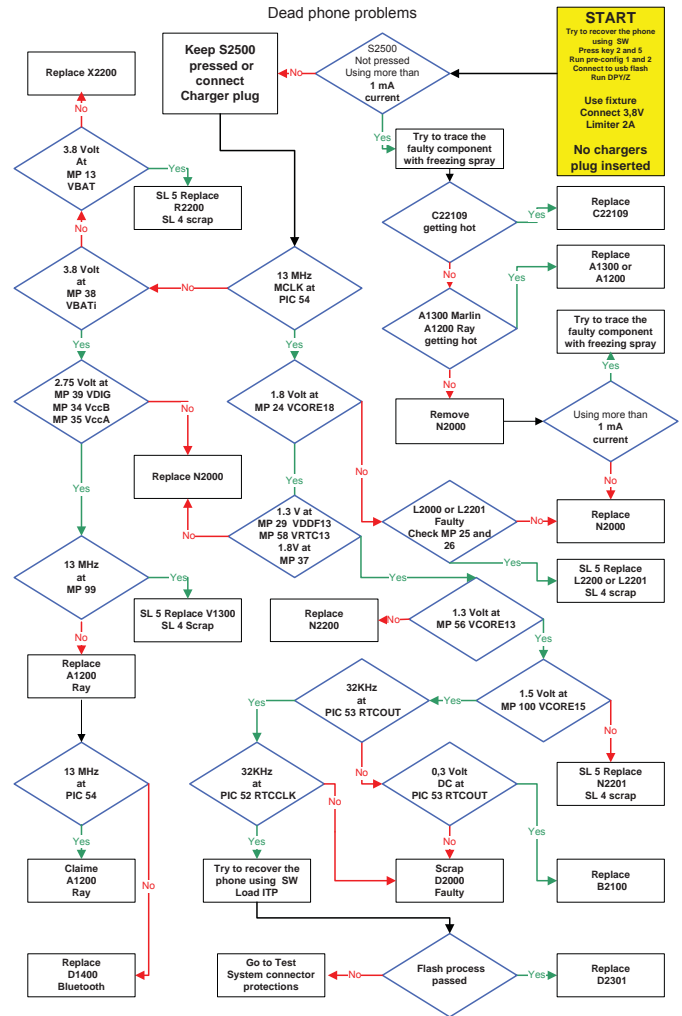
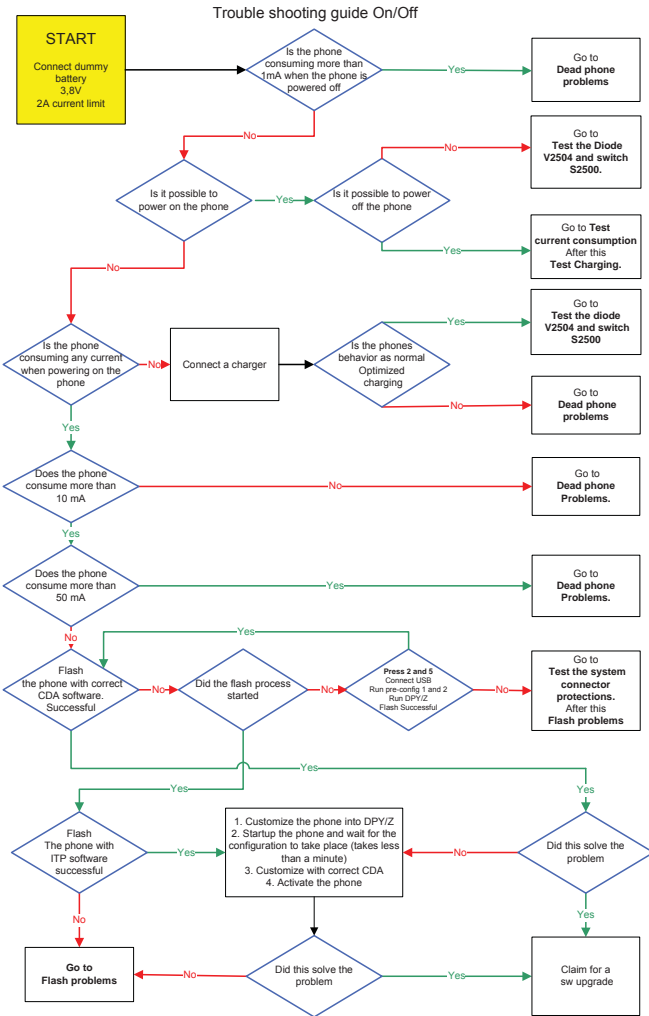

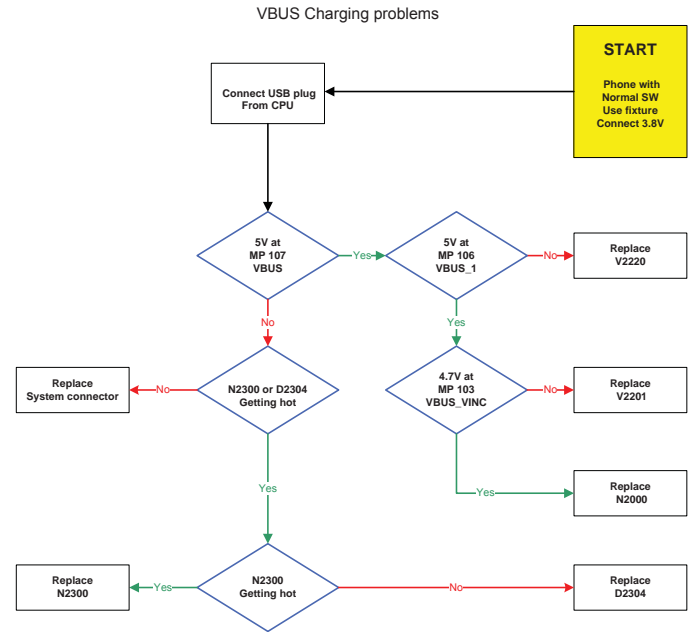
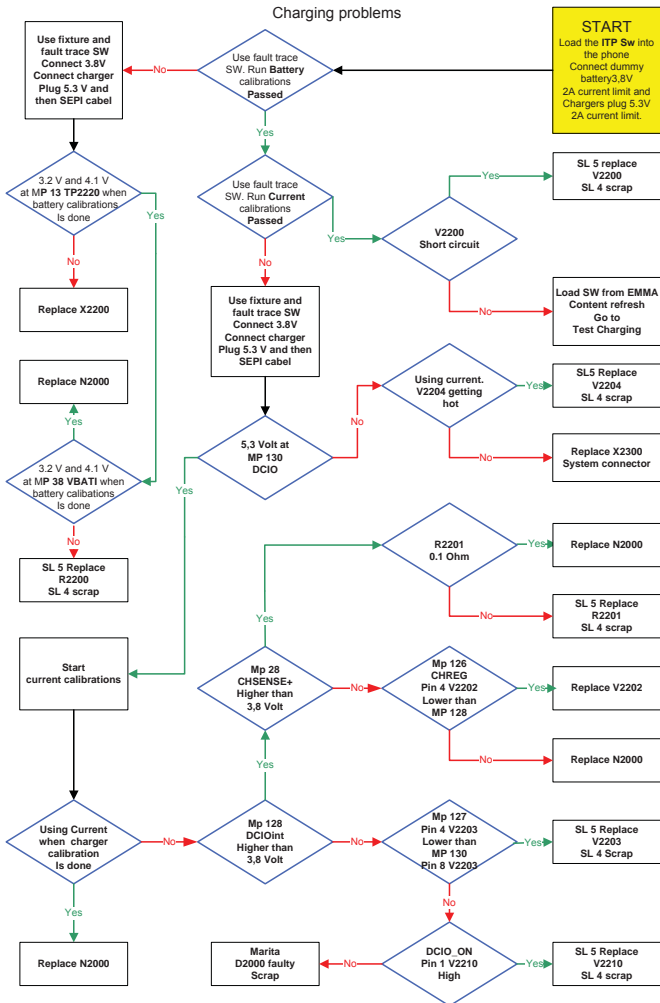

Keyboard and Display backlights problems

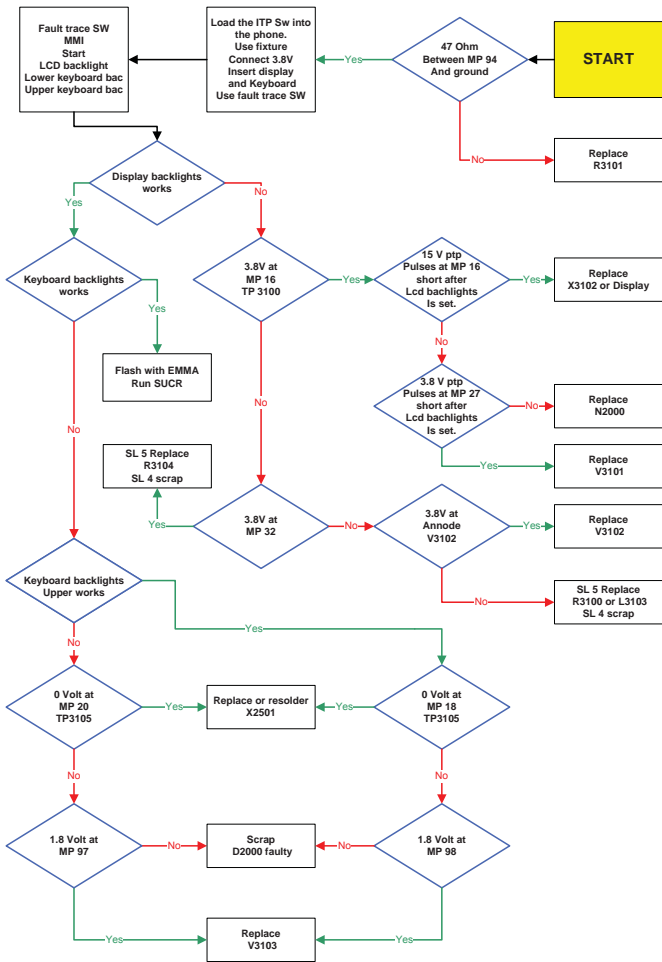

SIM problems

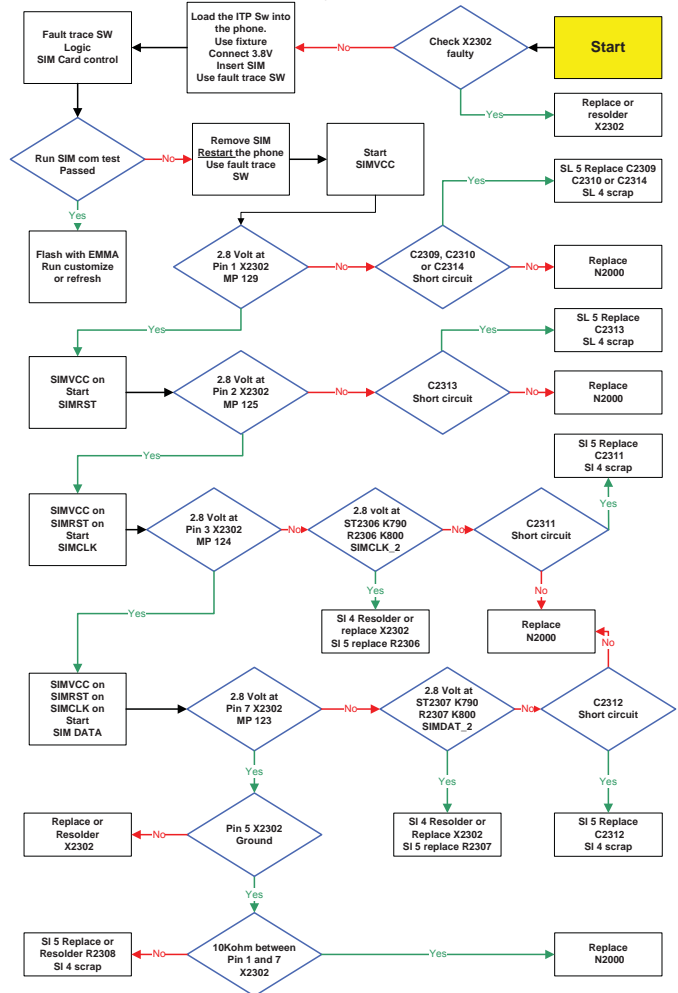

Flash problems

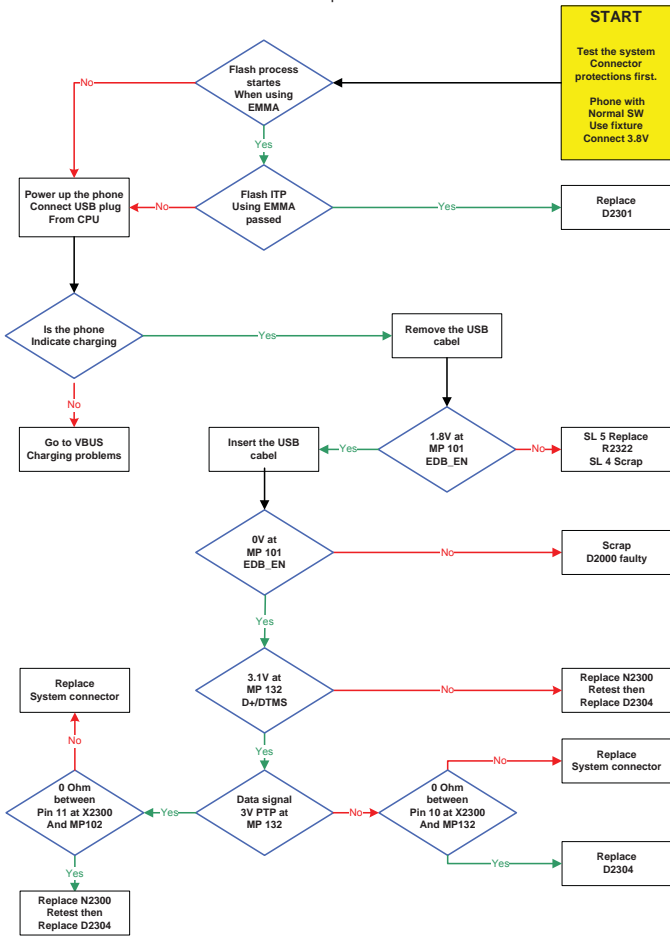

Audio internal problems

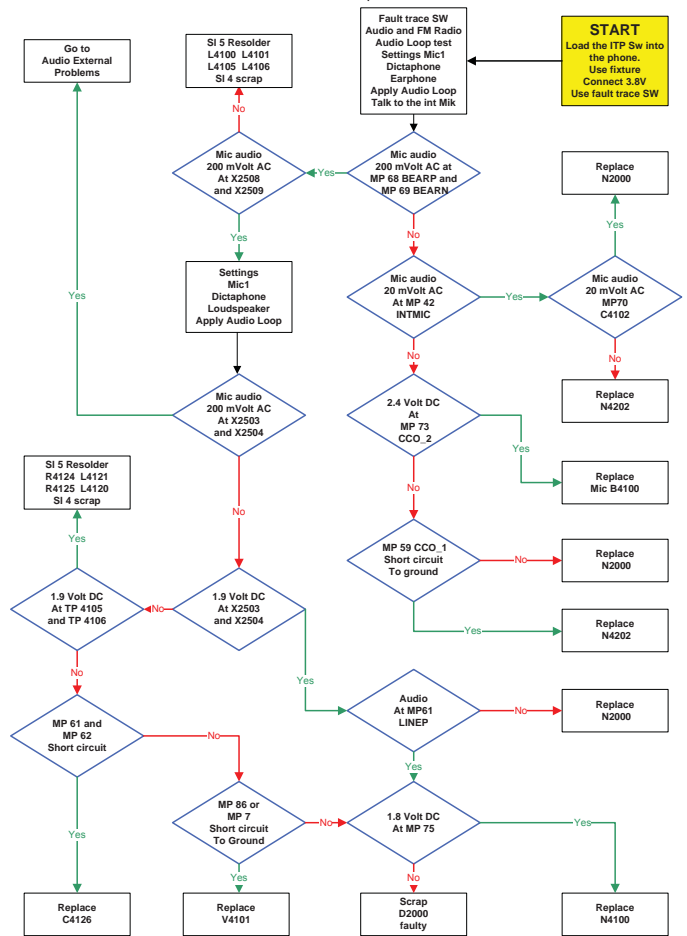

Audio external problems

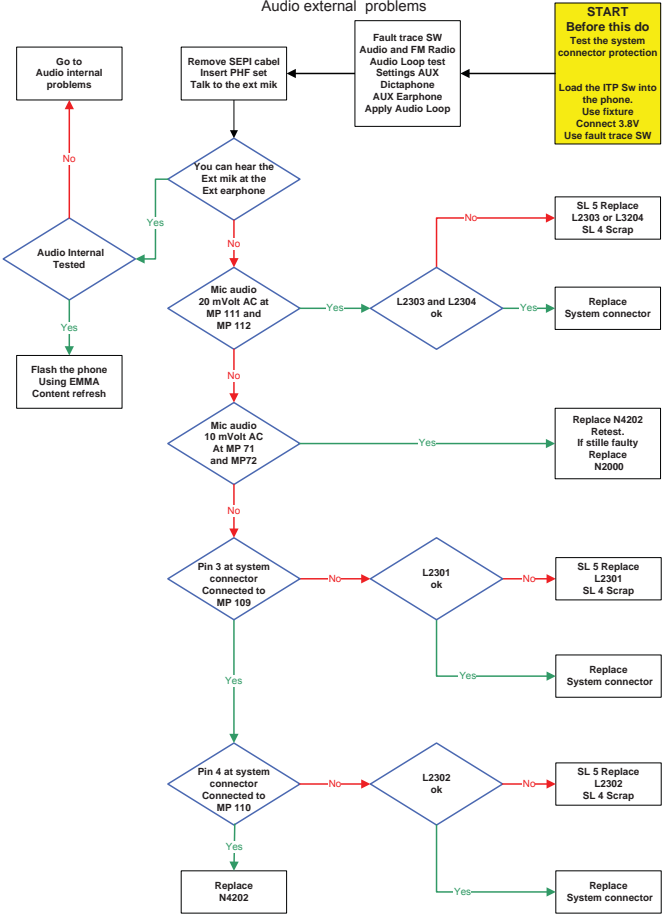

Camera problems

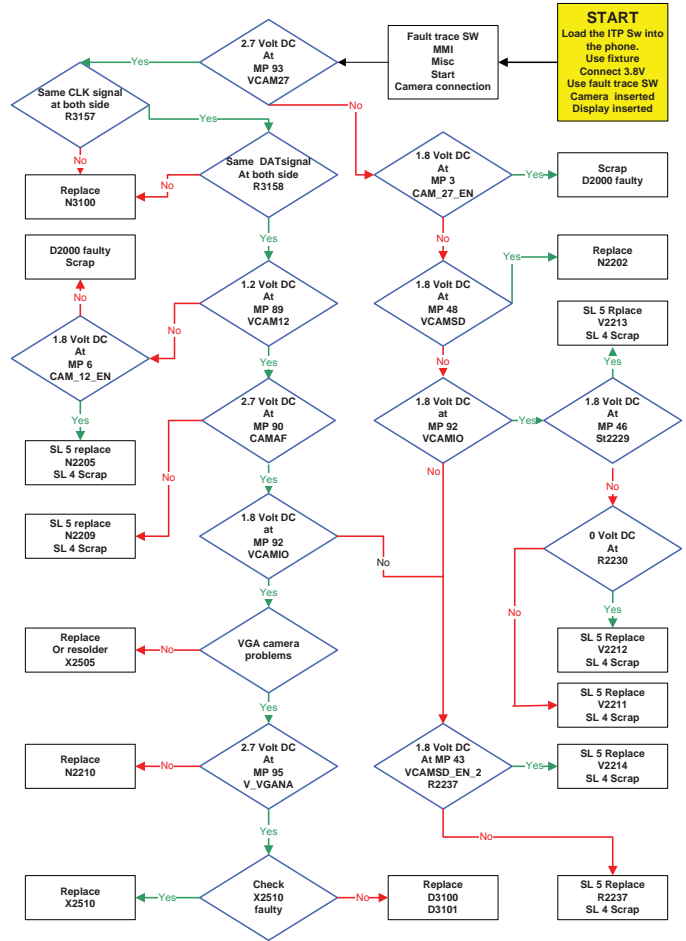

FM Radio problems

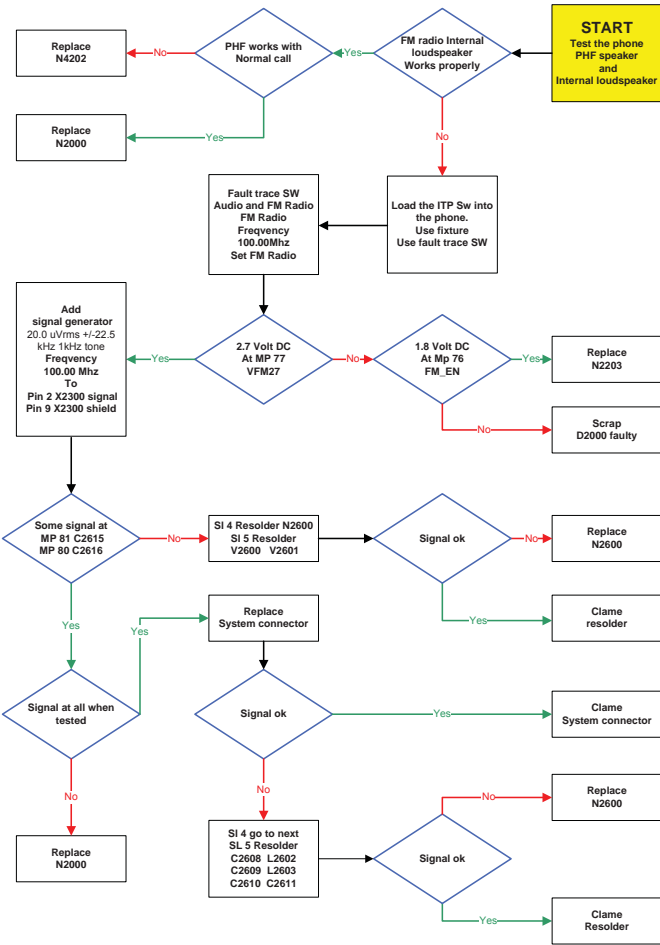

Vibrator problems

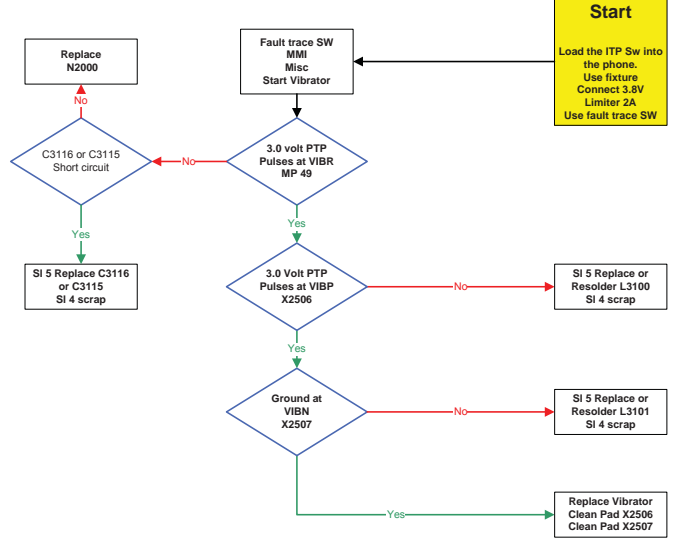

Memory stick problems

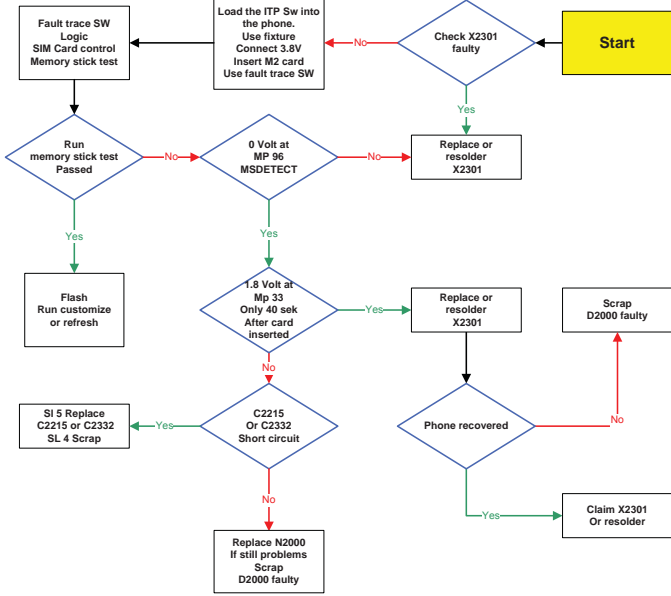

Bluetooth problems

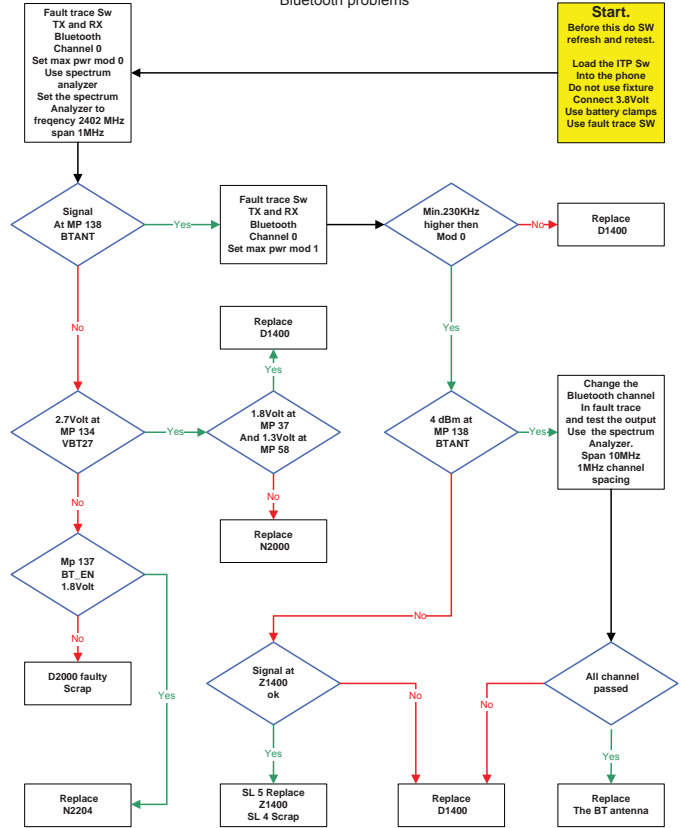

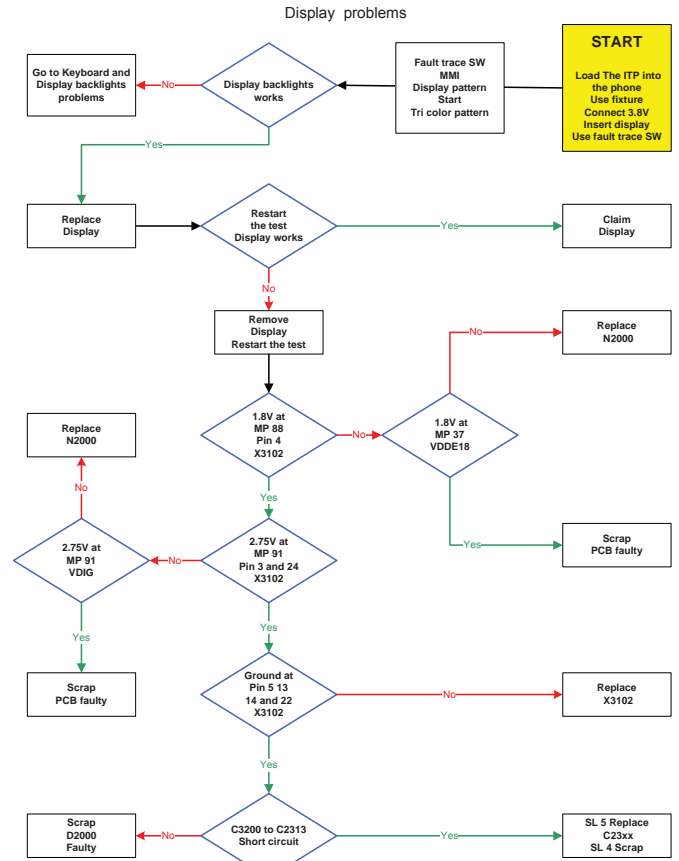
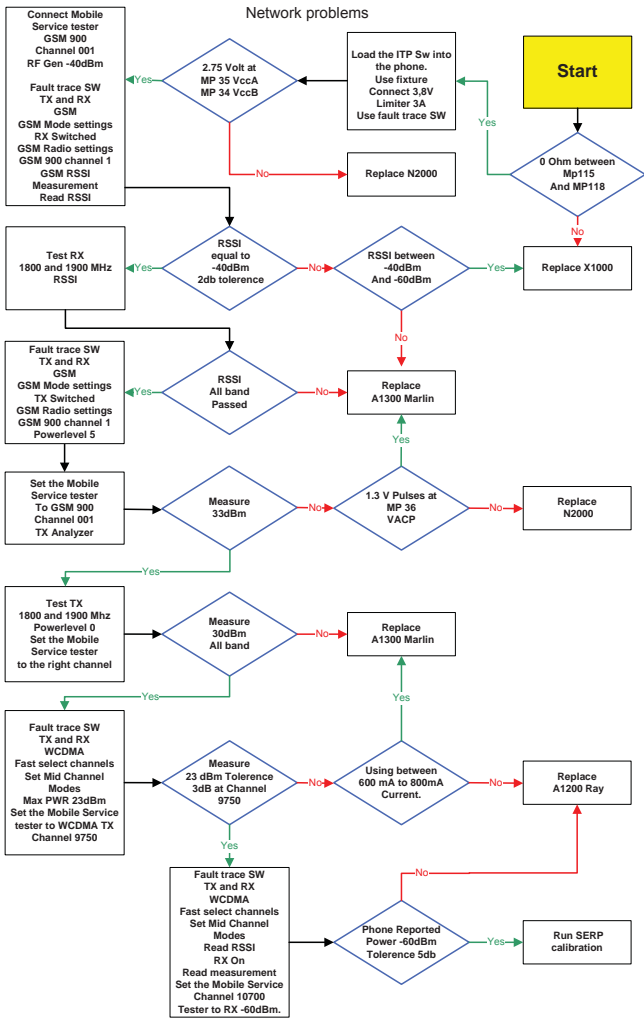

Test current consumptions

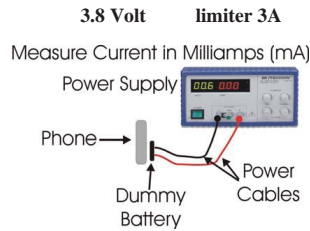

Connect the Dummy Battery (3.8 Volt, limiter 3A)
Measure the current in off mode, less than 1mA. If more, it could be Marlin A1300 or A1200 fault.

Insert a live SIM and power up the phone.

Measure the deep sleep current max 6mA typical between **0-3mA**.
If the phone uses more than 6mA, make a master reset. Make sure that the operator is running with deep sleep. (This operation can be switched off by operator if the network is busy).

Insert a test SIM and power up the phone to a network tester.

Measure the current in idle mode max 6mA typical between **0-3mA**.
Measure the Transmitter current 900 MHz power level 5. Max **400mA** (RMS) 1800mA (peak)
Measure the Transmitter current 1800 and 1900 MHz power level 0. Max **300mA** (RMS) 1500mA (peak)
Measure the Transmitter current WCDMA at 23dBm output power. Max **900mA** (RMS) 3000mA (peak).
If the phone uses more the fault could be fixed by running SERP calibrating or the fault is in the Marlin A1300, Ray A1200 or Vincenne N2000.

If Using fault trace Sw and ITP loaded in the phone the current consumptions are as followed.
Transmitter current 900 MHz at power level 5. Typical **300mA** (RMS)
Transmitter current 1800 and 1900 MHz at power level 0. Typical **250mA** (RMS)
Current in WCDMA mode at max power level 23 dBm and Rx on. Typical **750mA** (RMS)

If the current consumptions are equal to the sheet then go to **charging test**.

Test Charging

Current at 20sek. after chargers plug
I has been inserted (20 % tolerance)

Dummy battery (Volt)	3.0	3.1	3.2	3.3	3.4	3.5	3.6	3.7	3.8	3.9	4.0	4.1	4.2
Chargers plug 5.3 Volt. Current mA	250	250	600	700	800	800	800	800	800	800	800	800	0
LCD show charging X % to 100% indicator			0	0	0	10	10	20	60	80	90	90	
LCD show	Nothing											Fully charged	

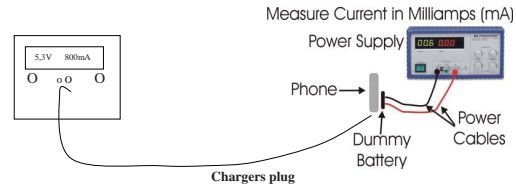

The power supplier at 3.8 Volt must allow reverse current.

If the charging current is **not** equal to the sheet go to **Charging problems**.

If the charging current is equal to the sheet then insert the normal battery and test the charging current to define if the battery is working properly.

Measure the voltage at the battery to define the current level.

If the battery is receiving the right current, then the phone and the battery are working properly.

Test the ASIC revisions

The purpose with this test is to see that all larger ASICs used are working, that the communication to the ASICs works and that the revisions of the ASICs are correct.

The ASICs tested are:

D2000 Marika , N2000 Vincenne2, D1400 Bluetooth ASIC,

N2600 FM Radio ASIC and D2301 NAND memory.

How to perform the test?

Load ITP to the phone.
Use fault trace SW
General
ASIC revisions
READ all

	ASIC	Product number	Return value (hex)
D2000	Marika Volume	ROP 101 3083/X	99 00
N2000	Vincenne2	ROP 101 3066/4	E3
D1400	Bluetooth:	RYT 123 922/1	
	HCI Revision		0402
	LMP Subversion		0520
N2600	FM Radio	RYT 109 905/3	5764
D2301	NAND memory:	RYT 118 932/2	
	Samsung, 512 MBit		EC,36
	ST, 512 MBit		20,36

Test Backup Capacitor.

This test should be performed in 3 steps.

Step1:

Measure the voltage at the Back up capacitor using **fault trace SW, Logic ADC Channels GP7-Vbackup** and read the Adc value (reading1).

Step2:

This step should be done **10 seconds** after step 1. Measure the voltage at the Back up capacitor using **fault trace SW Logic ADC Channels GP7-Vbackup** and read the Adc value (reading2).

Step3:

Compare the difference between reading 1 and reading 2 with the limits.

Limits

	Min	Max	Unit
Absolute readout Reading 1	1	120	Dec

Reading 1 (Dec)	Reading 2-Reading 1 (Dec)	
	Min	Max
Interval 1 (1 – 32)	4	40
Interval 2 (33 – 64)	2	35
Interval 3 (65 – 96)	2	25
Interval 4 (97 – 120)	1	12

Note: The upper table contains the absolute limits for the readouts. The lower table contains the allowed delta between the first and the second readout, separated in time with 10s.

If the readings is out of limits replace C2217 Backup capacitor.

If the fault exists replace N2000 Vincenne2.

Test the joystick Switch S2504 and the diodes V2503, V2506, V2507, V2508 and V2509.

Place the phone as picture Joystick up, system connector at right.
Remove the keyboard.
Connect the black probe onto **MP 22** or pin 7 (frame) at joystick.
Connect red probe onto **MP 1** to **MP 82**.

Measure Diode Voltage (VDC →)



Multimeter

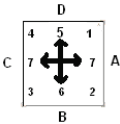
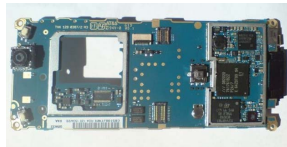

Joystick	10	4	82	47	1	MP
No action	1.8-OL	1.8-OL	1.8-OL	1.8-OL	1.8-OL	Volt
A Right	1.8-OL	0.0-0.6	0.6	0.6	1.8-OL	Volt
B Down	1.8-OL	0.0-0.6	0.6	1.8-OL	0.6	Volt
C Left	0.6	0.0-0.6	1.8-OL	1.8-OL	0.6	Volt
D Up	0.6	0.0-0.6	1.8-OL	0.6	1.8-OL	Volt
Center push	1.8-OL	0.0-0.6	1.8-OL	1.8-OL	1.8-OL	Volt
	V2509	V2503	V2508	V2506	V2507	Diode

Go to **Test the joystick Switch S2504** if the measurements are **not** equal to the reference sheet
Go to **Test the diode V2500** if the measurements are equal to the reference sheet

Test the joystick Switch S2504

Connect the black probe onto pin 7 (frame) at joystick.
Connect the Red probe onto pin 1-6 at joystick.

Measure Diode Voltage (VDC →)



Multimeter

If the measurement are equal to the reference sheet,
the joystick is working properly.

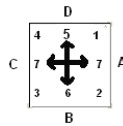

Joystick	4	6	2	1	3	Pin
No action	1.8-OL	1.8-OL	1.8-OL	1.8-OL	1.8-OL	Volt
A Right	1.8-OL	0.0	0.0	0.0	1.8-OL	Volt
B Down	1.8-OL	0.0	0.0	1.8-OL	0.0	Volt
C Left	0.0	0.0	1.8-OL	1.8-OL	0.0	Volt
D Up	0.0	0.0	1.8-OL	0.0	1.8-OL	Volt
Center push	1.8-OL	0.0	1.8-OL	1.8-OL	1.8-OL	Volt

Repair action if both joystick and diode test and joystick test is failed then replace the joystick switch S2504.

Repair action if joystick and diode test is failed and joystick test is passed.
SL5: compare the column in the sheet and replace the diode.
SL4: scrap the phone.

Test the diode V2500.

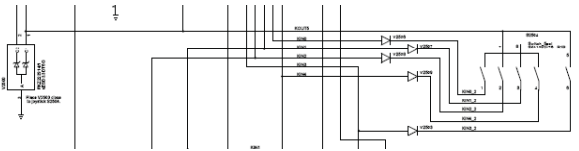

MP 23 MP22

Connect the Red probe onto **MP 44** or Ground.
Connect Black probe onto **MP 22** and **MP 23**.

Measure Diode Voltage (VDC →)



Multimeter

If the measurement are equal to the reference sheet,
the diode V2500 is working properly.

22	23	MP
0.6	0.6	Volt

Tolerance up to 20 %

Replace V2500 if the measurements are not equal to the reference sheet.

Test the protection diodes V2510 to V2514.

Connect the Black probe onto **MP 44** or Ground.
Connect the Red probe onto MP 1 to MP 120.

Measure Diode Voltage (VDC →)



Multimeter

2	82	10	120	4	117	MP
1.2-OL	1.2-OL	1.2-OL	1.2-OL	1.2-OL	1.2-OL	Volt
V2510	V2510	V2511	V2511	V2512	V2512	

83	1	47	19	MP
1.2-OL	1.2-OL	1.2-OL	1.2-OL	Volt
V2513	V2513	V2514	V2514	

If the measurement are equal to the reference sheet,
the diode V2511,V2511,V2512,V2513 and V2514 is not short circuit.

Repair action.

SL 5: Replace the faulty diode if the measurement is **not** equal to the reference sheet.
At very old product the diode is not mounted, Z2500 EDS filter is mounted instead.

SL 4: scrap the phone.

Test the diode V2504 and switch S2500.

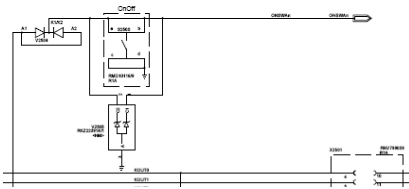

MP 47 MP 44 MP 85

Connect the Black probe onto MP 44 or Ground.
Connect the Red probe onto MP 47 and MP 85

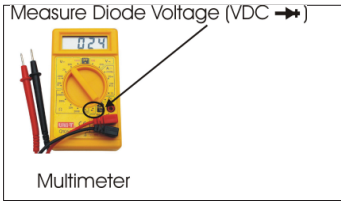

If the measurement are equal to the reference sheet,
The diode V2504 and S2500 is working properly.

S2500	47	85	MP
No action	1.4-OL	1.4-OL	Volt
Pressed	0.6	0.0	Volt

V2504 S2500
Tolerance up to 20 %

Repair actions if the measurements are **not** equal to the reference sheet.
Replace V2504 if MP 47 is wrong and MP 85 is right.
Remove S2500 if MP 85 is 0 Volt when S2500 is **not** pressed.
Replace N2000 if MP 85 is still 0 Volt after S2500 is removed.
Replace S2500 if MP 47 and MP 85 is 1.4 Volt when S2500 is pressed.

Test the Switch S2505 Game A.

Connect the Black probe onto MP 82.
Connect the Red probe onto MP 83.

Measure Diode Voltage (VDC →→)



Multimeter

No key pressed	1.4-OL	Volt
S2505 pressed	0	Volt

If the measurement are equal to the reference sheet,
The switch S2505 is working properly.
Replace S2505 if the measurements are **not** equal to the reference sheet.

Test the Switch S2506 Game B.

Connect the Black probe onto MP 1.
Connect the Red probe onto MP 2.

Measure Diode Voltage (VDC →→)



Multimeter

No key pressed	1.4-OL	Volt
S2506 pressed	0	Volt

If the measurement are equal to the reference sheet,
The switch S2506 is working properly.
Replace S2506 if the measurements are **not** equal to the reference sheet.

Test the Switch S2502 Volume down.

Place the phone as picture joystick down, system connector at right.

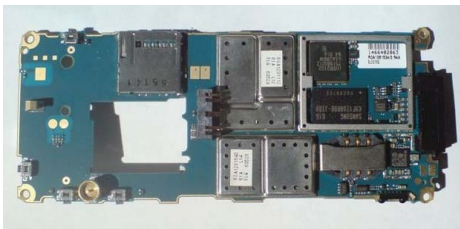

Connect the Black probe onto **MP 120**.
Connect the Red probe onto **MP 119**.

Measure Diode Voltage (VDC →)



Multimeter

No key pressed	1.4-0l	Volt
S2502 pressed	0	Volt

If the measurement are equal to the reference sheet,
The switch S2502 is working properly.
Replace S2502 if the measurements are **not** equal to the reference sheet.

Test the Switch S2503 Volume Up.

Connect the Black probe onto **MP 117**.
Connect the Red probe onto **MP 116**.

Measure Diode Voltage (VDC →)



Multimeter

No key pressed	1.4-0l	Volt
S2503 pressed	0	Volt

If the measurement are equal to the reference sheet,
The switch S2503 is working properly.
Replace S2503 if the measurements are **not** equal to the reference sheet.

Test the Switch S2507 Music.

Connect the Black probe onto **MP 122**.
Connect the Red probe onto **MP 121**.

Measure Diode Voltage (VDC →)



Multimeter

No key pressed	1.4-0l	Volt
S2507 pressed	0	Volt

If the measurement are equal to the reference sheet,
The switch S2507 is working properly.
Replace S2507 if the measurements are **not** equal to the reference sheet.

Joystick and other keys problems.

All the measurements are equal to the reference sheet.

The fault is:

1. Keyboard,
2. ESD Z2500 if mounted. (Z2500 is mounted at very old product)
3. Marika D2000

Start replacing the keyboard.

SL 5 if the fault exists then re solder or replace Z2500 if mounted.

If the fault exists the fault is Marika D2000, scrap the phone.

Keyboard problems.

1. All the measurements are equal to the reference sheet.
2. Joystick, side keys and game keys are working properly.

The fault is:

- 1: keyboard
- 2: keyboard connector X2501.

Start replacing the keyboard if the fault exists then re solder or replace X2501.

Test the system connector protections.

Perform voltage measurements with a multimeter.

Connect the black probe at ground (Pin 9 system connector)

Measure Diode Voltage (VDC)



Multimeter



Pin 1 Pin 9 Pin 12

Pin at system connector	1	2	3	4	5	6	7	8	9	10	11	12
Diode measurements if lower than x.x Volt	2.0	1.0	1.4	0.7	1.0	1.0	2.0	0.9	0.0	2.0	1.8	2.0
Do this repair action												
Service level 4 replace	N2300	N4202	N4202	N4202	N4202	N4202	Scrap	Scrap	Ground	N2300	N2300	Scrap
Service level 5 replace		V2303					V2303	V2221				V2204

Reference MP

MP: To Vincenne 2.

MP	MP 11	MP 13	MP 38	MP 12	MP 26	Power sup 3.8 Volt
	Ground	VBAT	VBATI	VBATA		
Phone Off	0.00	3.80	3.80	0.00	3.80	
Phone On	0.00	3.80	3.80	0.00	3.80	
Phone On	0.00	3.80	3.80	0.00	3.80	

MP: FromVincenne 2.

MP	MP 34	MP 35	Mp 39	Mp 24	MP37	MP 100	MP29	MP 56	MP 58	MP 51	
	VccB	VccA	VDIG	VCORE18	VDDE18	VCORE15	VDDF13	VCORE13	VRTC13		
	0.00	0.00	0.00	0.00	0.00	0.00	0.00	0.00	1.30	1.30	Power sup 0.0 Volt
Phone Off	0.00	0.00	0.00	0.00	0.00	0.00	0.00	0.00	1.30	1.30	Power sup 3.80 Volt
Phone On	2.75	2.75	2.75	1.80	1.80	1.50	1.3	1.30	1.30	1.30	Power sup 3.80 Volt
										C 2217	completely charged

MP: Bluetooth

MP	MP 134	Mp 137
	VBT27	VBT_EN
BT Off	0.00	0.00
BT On	2.70	1.80

MP: FM Radio

MP	MP 77	Mp 76
	VFM27	FM_EN
FM Off	0.00	0.00
FM On	2.70	1.80

MP: Charging.



Power sup 3.8 Volt						Phone loaded SW ITP
MP	Mp 28	Mp 128	Mp 126	Mp 127	Mp 130	
onto	R2201	Dicoint	V2202 pin 4	V2210 pin 4	DCIO	
Charging off	3.8	3.6	3.6	3.6	0.0	Charger voltage 0 Volt
Charging off	3.8	5.0	5.0	5.0	5.3	Charger voltage 5.3 Volt
Charging 100mA	3.9	4.7	3.6	4.7	5.3	Charger voltage 5.3 Volt
Charging 800mA	4.1	4.3	2.9	4.3	5.0	Charger voltage 5.3 Volt

MP: Cameras.









MP	MP 3	Mp 95	MP 6	Mp 43	MP 46	MP 48	MP 92	MP 89	Power sup 3.8 V.
	CAM_EN	V_VGAANA	CAM_12_EN	VCAMSD_EN_2	V_VGADIG	VCAMSD	VCAMIO	VCAM12	
CAMERA Off	0.00	0.00	0.00	0.00	0.00	0.00	0.00	0.00	
CAMERA On	2.70	2.70	1.80	1.80	1.80	1.80	1.80	1.20	

Part	Part Location on Phone	Working Instruction Description	Webshop Description	Part Number	Comment
		Receiver	Ear Speaker	RLE 908 24/2	
		Antenna Port Plug	Plug (external antenna)	SXA 109 6481	Black
				SXA 109 6481/1	Brown
				SXA 109 6481/3	Silver
		1.4MM Screw	Screw M1.4 x 4	SXA 109 6306	
		1.7MM Screw	Screw 1.7mm self threading	SXA 109 5242	
		Board Frame	Frame Assembly	SXK 109 6856	
		Conductive Cylinder	Rubber Connector, Front	SXA 109 6537	
		LCD Conductive Cylinder	Rubber Connector, LCD	SXA 109 6540	

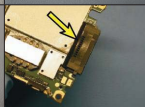
		LCD Assembly	LCD Assembly	RNH 942 268	
		LCD Holder	LCD Holder Assembly	SXK 109 6963	
		Metal Retaining Strap	ESD protection sheet, LCD	SXA 109 6413	
		Rear Camera Module	Camera	KNC 20125	
		Flash Assembly	Xenon Flash	RKZ 433970	
		Battery Cover	Battery Lid Assembly	SXK 109 6866	Black
				SXK 109 6866/2	Brown
				SXK 109 6866/3	Silver
		Co-brand Label	Co-brand Label	SXA 109 6313/2	Black/ CMCC
				SXA 109 6313/3	Black/ T-mobile
				SXA 109 6313/4	Black/ Orange
				SXA 109 6313/5	Black/ Vodafone
				SXA 109 6313/7	Black/ Hutchinson
				SXA 109 6313/8	Black/ Telefonica
				SXA 109 6313/9	Black/ Swisscom
				SXA 109 6313/10	Black/ SFR
				SXA 109 6313/11	Black/ Cingular
				SXA 109 6313/13	Black/ Mobilcom

				SXA 109 6313/15	Black / Virgin Mobile
				SXA 109 6824/2	Brown/ CMCC
				SXA 109 6824/5	Brown/ Vodafone
				SXA 109 6824/7	Brown/ Hutchinson
		Keyfoil Assembly	Keyfoil Assembly	ROA 128 1764	
		Keyfoil Support Plate	Key Support Plate	SXX 109 7140	
		Key Support Plate Adhesive Film	Key Support Plate Tape	SXA 109 6724	
		Label	KRH Label	SVF 930 1478	
		Numeric Keyboard	Numeric Keyboard	SXA 109 6376/1	Black/ Latin
				SXA 109 6376/2	Black/ Latin/Stroke
				SXA 109 6376/3	Black/ Bopomofo
				SXA 109 6376/4	Black/ Hebrew
				SXA 109 6376/5	Black/ Cyrillic
				SXA 109 6376/6	Black/ Latin / Thai
				SXA 109 6376/7	Black/ Hindi
				SXA 109 6376/8	Black/ Arabic
				SXA 109 6636/1	Brown/ Latin
				SXA 109 6636/2	Brown/ Stroke
				SXA 109 6636/3	Brown/ Bopomofo

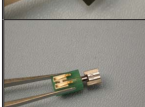
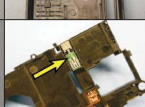

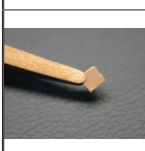
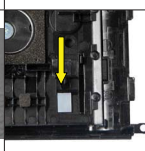







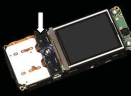

				SXA 109 6636/4	Brown/ Hebrew
				SXA 109 6636/5	Brown/ Cyrillic
				SXA 109 6636/6	Brown/ Latin Thai
				SXA 109 6636/7	Brown/ Hindi
				SXA 109 6636/8	Brown/ Arabic
				SXA 109 7317/1	Silver/ Latin
				SXA 109 7317/2	Silver/ Latin/Stroke
				SXA 109 7317/3	Silver/ Arabic
				SXA 109 7317/4	Silver/ Cyrillic
				SXA 109 6669/1	Black/ Generic
				SXA 109 6669/3	Black/ Vodafone
				SXA 109 6669/5	Black/ CMCC
				SXA 109 6669/6	Black/ Orange
				SXA 109 6669/7	Black/ T-Mobile
		Functional Keyboard	Functional Keyboard	SXA 109 6669/8	Black/ Cingular
				SXA 109 6669/9	Black / Hutchinson
				SXA 109 6669/2	Brown/ Generic
				SXA 109 6669/4	Brown/ Vodafone
				SXA 109 6669/11	Brown/ CMCC
				SXA 109 6669/12	Brown/ Hutchinson
				SXA 109 6669/13	Brown/ Orange
		Joystick Gasket	Joystick Gasket	SXA 109 8126	Only for Functional keyboards R2A (R3A for SXA 109 6669/9) or higher in order to have a good feeling when you add the gasket

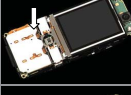





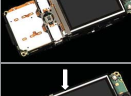



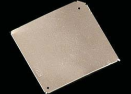

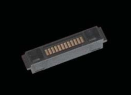







		System Connector	System Connector	RNV 79936	
		System Connector Foam Pad	Dust gasket large system connector	SXA 109 6165	
		Liquid Intrusion Indicator	Liquid Intrusion Indicator	SXA 109 4884	
		Rear Speaker Cloth	Loudspeaker Gasket	SXA 109 6300	
		Vibrator	Vibrator	BKE 90332	
		Antenna Cover	Antenna Cover Assembly	SXK 109 6859	Black
				SXK 109 6859/2	Brown
				SXK 109 6859/6	Silver (old part number SXK 109 6859/5)
		Camera Support Pad	Camera Support Pad	SXA 109 7348	







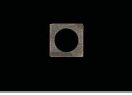





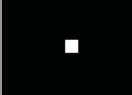





		Memory Stick Cover	MS Cover	SXA 109 6296	Black
				SXA 109 6296/2	Brown
				SXA 109 6296/3	Silver
		Volume Key	Volume Key	SXA 109 6292	Black
				SXA 109 6292/2	Brown
				SXA 109 6292/3	Silver
		Power Key	On/Off Key	SXA 109 6294	
				SXA 109 6295	Black
				SXA 109 6295/2	Brown
		Music Player Key	Music Player Key	SXA 109 6295/3	Silver
				SXA 109 6293	
				SXA 109 6293	
		Camera Key	Camera Key	SXA 109 6293	
				SXA 109 6161	
				SXA 109 6161	
		Insulation Label	Insulation Label (Shield Can)	SXA 109 6161	
				SXA 109 7268	
				SXA 109 7268	
		Shield Can Lid over Camera Connection	Shield can lid, camera assembly	SXK 109 7268	
				SXK 109 7268	
				SXK 109 7268	
		HPM-62 Stereo Headphones	HPM-62/Stereo PHF	RLF 501 62	
				RLF 501 62	
				RLF 501 62	

		64MB Memory Stick Micro(M2)	64MB Memory Stick Micro(M2)	KDR 109 171/64	
		Dust Preventing Tape	Dust Preventing Tape	SXA 109 8088	
		Antenna/Speaker Box Assembly	Antenna/Speaker Box Assembly	SXX 109 6930	
		Front Camera	VGA Camera	KNC 201 16	
		Front Cover Assembly	Front Assy Complete /Black	SXX 109 6857/Z	Black
			Front Assy Complete /Black Cybershot	SXX 109 6857/3Z	Black
			Front Assy Complete /Brown	SXX 109 6857/2Z	Brown
			Front Assy Complete /Brown Cybershot	SXX 109 6857/4Z	Brown
			Front Assy Complete /Silver Cybershot	SXX 109 6857/5Z	Silver
			Front Assy Complete /Silver	SXX 109 6857/6Z	Silver



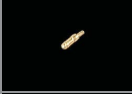







Part	Part Location on Phone	Working Instruction Description	Webshop Description	Part Number
		Battery lid assembly	Battery lid assembly/Noble Blue Battery lid assembly/Golden Ivory Battery lid assembly/Pulse Red	SXX1097675 SXX1097675/2 SXX1097675/3
		MS Cover	MS Cover/Noble Blue MS Cover/Golden Ivory MS Cover/Pulse Red	SXA1097683 SXA1097683/2 SXA1097683/3
		Antenna cover assembly	Antenna cover assembly Noble Blue Antenna cover assembly Golden Ivory Antenna cover assembly Pulse Red	SXX1097674 SXX1097674/2 SXX1097674/3
		Screw 1,7 x 6mm	Screw 1,7 x 6mm	SXA1097716
		Function keyboard Assys	Function keyboard Assys Nobel Blue Generic Function keyboard Assys Nobel Blue Orange Function keyboard Assys Nobel Blue Vodafone Function keyboard Assys Nobel Blue T-Mobile Function keyboard Assys Nobel Blue Hutch Function keyboard Assys Golden Ivory Generic Function keyboard Assys Golden Ivory Orange Function keyboard Assys Golden Ivory Vodafone Function keyboard Assys Golden Ivory T-mobile Function keyboard Assys Golden Ivory Hutch	SXX1097706/1 SXX1097706/2 SXX1097706/3 SXX1097706/4 SXX1097706/8 SXX1097706/21 SXX1097706/22 SXX1097706/23 SXX1097706/24 SXX1097706/28

		Function keyboard Assys	Function keyboard Assys Pulse Red Generic Function keyboard Assys Pulse Red Orange Function keyboard Assys Pulse Red Vodafone Function keyboard Assys Pulse Red T-mobile Function keyboard Assys Pulse Red TIM Function keyboard Assys Pulse Red Hutch Function keyboard Assys Pulse Red CMCC	SXX1097706/41 SXX1097706/42 SXX1097706/43 SXX1097706/44 SXX1097706/45 SXX1097706/48 SXX1097706/53
		Antenna/ Speakerbox assembly	Antenna/ Speakerbox assembly	SXX1097667
		Keyfoil Complete	Keyfoil Complete	SXX1097719
		ESD protection sheet LCD	ESD protection sheet LCD	SXA1097659
		Screw 1,7 x 7mm	Screw 1,7 x 7mm	SXA1097717
		LCD	LCD	RNH942286
		LCD holder assembly	LCD holder assembly	SXX1097669

		Shield can lid, camera assy	Shield can lid, camera assy	SXK1097268
		System connector	System connector	RNV79936
		Dust gasket, system connector	Dust gasket, system connector	SXA1096165
		Insulation label	Insulation label	SXA1096161
		Camera	Camera	KNC20125
		Frame Assembly	Frame Assembly	SXK1097666
		Vibrator	Vibrator	BKE90324
		Microphone gasket	Microphone gasket	SXA1096298
		VGA camera	VGA camera	KNC20116
		VGA Socket Gasket	VGA Socket Gasket	SXA1097865

		Screw M1.4x5	Screw M1.4x5	SXA1096306
		Liquid indicator	Liquid indicator	SXA1094884
		Plug (external antenna)	Plug (external antenna) Noble Blue Plug (external antenna) Golden Ivory Plug (external antenna) Pulse Red	SXA1097681 SXA1097681/2 SXA1097681/3
		Tape (holder capacitor)	Tape (holder capacitor)	SXA1097100
		Xenon flash	Xenon flash	RKZ433999
		Numeric keyboard	Numeric keyboard/Noble Blue Numeric keyboard/Golden Ivory Numeric keyboard/Pulse Red	SXA1097690/1 SXA1097690/2 SXA1097690/3
		Camera key	Camera key Camera key/Pulse Red	SXA1097663 SXA1097663/3
		Ground Connector	Ground Connector	SXA1097718
		VGA camera window	VGA camera window	SXA1097724

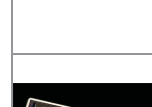
		Ear Speaker	Ear Speaker	RLE90824/2
		Front Assy	Front Assy Nobel Blue Front Assy Golden Ivory Front Assy Pulse Red	SXK1097673 SXK1097673/2 SXK1097673/3
		Earspeaker gasket	Earspeaker gasket	SXA1097673
		A/B key	A/B key Nobel Blue A/B key Golden Ivory A/B key Pulse Red	SXA1097661 SXA1097661/2 SXA1097661/3
		Loudspeaker gasket	Loudspeaker gasket	SXA1097771
		Music Player Key	Music Player Key/Noble Blue Music Player Key/Golden Ivory Music Player Key/Pulse Red	SXA1097665 SXA1097665/2 SXA1097665/3
		Volume key	Volume key/Noble Blue Volume key/Golden Ivory Volume key/Pulse Red	SXA1097662 SXA1097662/2 SXA1097662/3
		On/Off Key	On/Off Key/Noble Blue On/Off Key/Golden ivory On/Off Key/Pulse Red	SXA1097664 SXA1097664/2 SXA1097664/3
		KRH Label	KRH Label	SVF9301478

		Handstrap plate	Handstrap plate	SXA1097652
		128Mb Memory Stick micro (M2)	128Mb Memory Stick micro (M2)	KDR 109171/128
		Front complete	K810i/Front complete/Z/ Noble Blue/Latin/Cybershot K810i/Front complete/Z/ Noble Blue/Arabic/Cybershot K810i/Front complete/Z/ Noble Blue/Stroke/Cybershot K810i/Front complete/Z/ Noble Blue/Thai/Cybershot K810i/Front complete/Z/ Noble Blue/Bopomoto/Cybershot K810i/Front complete/Z/ Noble Blue/Cyrillic/Cybershot K810i/Front complete/Z/ Noble Blue/Latin/Orange K810i/Front complete/Z/ Noble Blue/Latin/T-Mobile K810i/Front complete/Z/ Noble Blue/Latin/TIM K810i/Front complete/Z/ Noble Blue/Latin/Telefonica	SXK1097852/1 SXK1097852/2 SXK1097852/3 SXK1097852/4 SXK1097852/5 SXK1097852/7 SXK1097852/8 SXK1097852/10 SXK1097852/11 SXK1097852/12
		Front complete	K810i/Front complete/Z/ Golden Ivory/Latin/Cybershot K810i/Front complete/Z/ Golden Ivory/Arabic/Cybershot K810i/Front complete/Z/ Golden Ivory/Stroke/Cybershot K810i/Front complete/Z/ Golden Ivory/Thai/Cybershot K810i/Front complete/Z/ Golden Ivory/Bopomoto/Cybershot K810i/Front complete/Z/ Golden Ivory/Cyrillic/Cybershot	SXK 109 7852/22 SXK 109 7852/23 SXK 109 7852/24 SXK 109 7852/25 SXK 109 7852/26 SXK 109 7852/28
		Front complete	K810i/Front complete/Z/ Pulse Red/Latin/Cybershot K810i/Front complete/Z/ Pulse Red/Arabic/Cybershot K810i/Front complete/Z/ Pulse Red/Stroke/Cybershot K810i/Front complete/Z/ Pulse Red /Thai/Cybershot K810i/Front complete/Z/ Pulse Red /Bopomoto/Cybershot K810i/Front complete/Z/ Pulse Red /Hebrew/Cybershot K810i/Front complete/Z/ Pulse Red /Cyrillic/Cybershot	SXK 109 7852/43 SXK 109 7852/44 SXK 109 7852/45 SXK 109 7852/46 SXK 109 7852/47 SXK 109 7852/48 SXK 109 7852/49

Part List Main Board

This list contains only components that are possible to replace on the main board. Pos. number refers to the components position number on the board. Component placing can be found on pages 43 – 45 in this manual.

Some components are noted as MSL X. These components are moisture-sensitive and are rated at various levels (MSL):

- Level 1:** Unlimited floor life; does not require dry pack or re-baking.
- Level 2:** 1 year floor life; </=30 C; 60%rh; shipped in dry pack; must be re-baked after being opened if floor life is exceeded.
- Level 2A:** 4 week floor life; </=30 C; 60%rh; shipped in dry pack; must be re-baked after being opened if floor life is exceeded.
- Level 3:** 168 hours floor life; </=30 C; 60%rh; shipped in dry pack; must be re-baked after being opened if floor life is exceeded.
- Level 4:** 72 hours floor life; </=30 C; 60%rh; shipped in dry pack; must be re-baked after being opened if floor life is exceeded.
- Level 5:** 48 hours floor life; </=30 C; 60%rh; shipped in dry pack; must be re-baked after being opened if floor life is exceeded.
- Level 5A:** 24 hours floor life; </=30 C; 60%rh; shipped in dry pack; must be re-baked after being opened if floor life is exceeded.
- Level 6:** 6 hours floor life; </=30 C; 60%rh; shipped in dry pack; must be re-baked after being opened if floor life is exceeded.

NOTE!
RF Calibration by using SERP can only be done by authorized repair centers.
Fence modification according to Working Instruction Electrical.

F = Front Side, B = Back Side

Side	Pos	Description	Part Number	Comments	Page
B	A1200	Ray/UMTS-module	ROA 128 1112/Z	Calibration Required MSL 5A Special Soldering Process Required	74
B	A1300	Marlin/GSM-module	ROA1281640/Z	Calibration Required MSL 5A Special Soldering Process Required	83
F	B2100	Crystal 32768HZ +20PPM 12.5pF	RTM501911/1	Calibration Required	90
F	B4100	Microphone RF Improved	RLC509427/3		90
F	C2217	0.07F 3.3V Capacitor	RJE3551335/7		91
F	C22109	Capacitor Ceramic 10,0 uF 6,3 V	RJC5164038/1		
B	D1400	MICROCIRCUIT/Bluetooth E-	RYT 123 923/2	MSL 3	91
B	D2301	512Mb NAND	RYT118932/2		92
B	D2304	USB transceiver and UART MUX	RYT109913/1		92
B	H2300	IRDA 6,7*2,45*1,7	RKZ923919/1		93
F	D3100 D3101	Octal bus transceiver	RYT109915/1		93
F	N2000	ASIC Vincenne2 A07 1.8V Cu-Plug Thin Ni (Pb-free package)	ROP1013066/6	Calibration Required MSL 3	94
F	N2200	LDO 1.3V	RYT1137810/1		94
F	N2202 N2203 N2204 N2210	Voltage regulator 2,8V	RYT1137824/1		95

Side	Pos	Description	Part Number	Comments	Page
B	N2300	USB FILTER NETWORK	RKZ923921/1		95
F	N2600	Single chip elec tuned FM stereo radio	RYT109905/3		96
F	N3100	Dual Bilateral Switch	RYT109933/1		96
F	N4100	1W OPAMP Pb-Free version	RYT101947/2		96
F	N4202	ASIC TJAATTE 3	ROP1013074/1		97
F	R3101	Resistor 47, Ohm +/-1% 50 mW	REP621102/47		
B	S2500 S2502 S2503 S2507	Side push switch	RMD10116/4		97
F	S2504	JOYSTICK SWITCH	SXA1092476		98
F	S2505 S2506	A/B key switch	RMD10147		98
B	V2201	Diode, Shottky, Pb Free	RKZ123918/1		99
B	V2202	P-CHANNEL MOSFET	RYN122684/2		99
B	V2220	Dual MOSFET complementary N-P	RYN123919/1		100
B	V2301	NPN transistor, SOT723, R1=22k	RYN121931/1	same as V2552	100
F	V2500	Dual ESD protection diode	RKZ223914/1	same as V4101	101
F	V2504	SWI X2 75V 2X75mA SC75	RKZ123904/1		101
F	V2552	NPN transistor, SOT723, R1=22k	RYN121931/1	same as V2301	100
F	V3101	Transistor, Mosfet, N-Channel, SC88	RYN123915/1		102
F	V3102	SCHOTTKY DIODE.	RKZ323907/1		102
B	V3103	Dual N-Channel 2.5V MOSFET	RYN901923/1		103
B	V3110	LED Red Side fire	RKZ433924/1		103
F	V3113	MOSFET, Dual P-CHANNEL NoPb	RYN122904/1		104
B	V4101	Dual ESD protection diode	RKZ223914/1	same as V2500	101
B	X1000	External Antenna connector	RPT79953		104
B	X1002	Int antenna connector	RPT79951		105
B	X2200	Battery connector	SND10622		105
B	X2301	M2 Memory Card Reader	RNK87147		106
B	X2302	Sim Reader	RNK87146		106
F	X2501	20 Pin BtB (female)	RNV799009		107
F	X2505	30 Pin BtB (male)	RNV79992		107
F	X2510	Socket VGA camera	RNV 799 015		107
F	X2550	FPC 10 pin (DDK)	RNV799019/10		108
F	X3102	26 Pin BtB (female)	RNV79994		108
B	Covers E1000	Shield can lid, Bb Prim/Assembly	SXK1096823		
F	Covers E1001	Shield can lid, Bb Sec	SXA 109 6371		
B	E1002	Shield Can BT	SXA 109 6043		

A1200 Ray/UMTS Module ROA 128 1112/Z

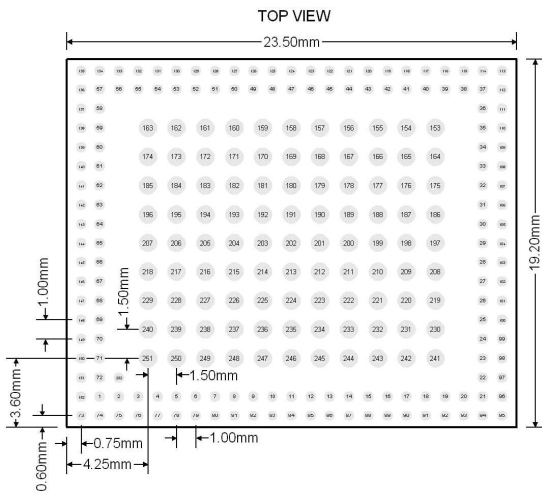

Note: Size 23.50 x 19.20 = Nominal PWB-size

Interface-pattern of the module:

Pin number	Copper pad	Soldermask opening
1-152	Round 0.57mm	Round 0.67mm
153-251	Round 1.00mm	Round 1.10mm
252 (pin 1 marking)	Round 0.57mm	Round 0.67mm

The interface have copper between the pads connected to signal: GND
Pins connected to GND could be connected the copper between pads.

Recommended interface-pattern for the motherboard:

Pin number	Copper pad	Soldermask opening
1-152	Round 0.67mm	Round 0.77mm
153-251	Round 1.10mm	Round 1.20mm
252 (pin 1 marking)	Round 0.67mm	Round 0.77mm

The outer layer using this footprint shall be filled with copper with good connection to GND. Isolation between signal copper and GND-plane filling: min 0.4mm

Pins / Signal cross-reference:

Pin number	Signal
1	VccB_mix
2-3, 6-8, 10-11, 13-14, 16-17, 18-19, 2129, 31, 33-34, 40-44, 46, 48-51, 55, 57, 62, 64-65, 67, 72, 73-251, 252	GND
4	XOOB
5	XOOA
9	VccB
12	CLKREQ
15	WRFLOOP
20	WCDMA_ANT
30	WCDMA_SENSE
32	WPABIAS
35-39	VBATI
45	RTEMP
47	XTLDO
52	WSTR
53	WDAT
54	WCLK
56	WON
58	TXIA
59	TXIB
60	TXQA
61	TXQB
63	MCLK
66	VCXOCONT
68	RXIB
69	RXIA
70	RXQB
71	RXQA

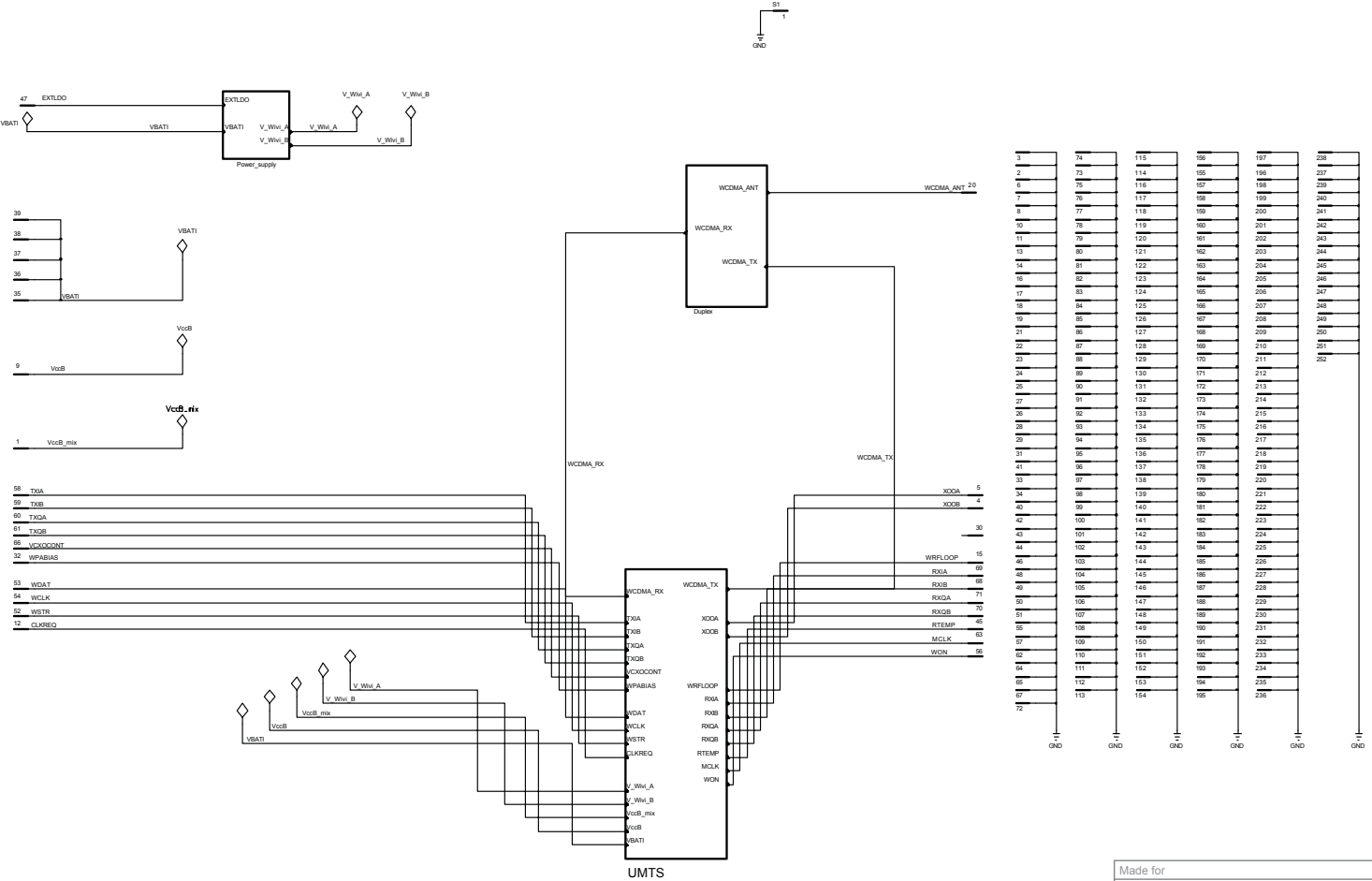

3	74	115	155	197	238
2	73	114	155	196	237
6	75	116	157	198	239
7	76	117	158	199	240
8	77	118	159	200	241
10	78	119	160	201	242
11	79	120	161	202	243
13	80	121	162	203	244
14	81	122	163	204	245
15	82	123	164	205	246
17	83	124	165	206	247
18	84	125	166	207	248
19	85	126	167	208	249
21	86	127	168	209	250
22	87	128	169	210	251
23	88	129	170	211	252
24	89	130	171	212	
25	90	131	172	213	
27	91	132	173	214	
28	92	133	174	215	
29	93	134	175	216	
31	94	135	176	217	
31	95	136	177	218	
41	96	137	178	219	
33	97	138	179	220	
34	98	139	180	221	
40	99	140	181	222	
42	100	141	182	223	
43	101	142	183	224	
44	102	143	184	225	
46	103	144	185	226	
48	104	145	186	227	
49	105	146	187	228	
50	106	147	188	229	
51	107	148	189	230	
52	108	149	190	231	
57	109	150	191	232	
62	110	151	192	233	
64	111	152	193	234	
65	112	153	194	235	
67	113	154	195	236	
72					

Made for	
RADIO TOP	
RAY/UMTS Module	
Document Nr	Revision
1/1911 - ROA 128 1112/1	

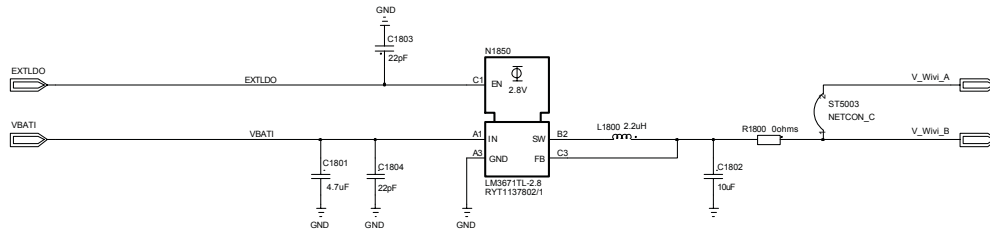

Made for	
RADIO Power Supply	
RAY/UMTS Module	
Document Nr	Revision
1/1911 - ROA 128 1112/2	

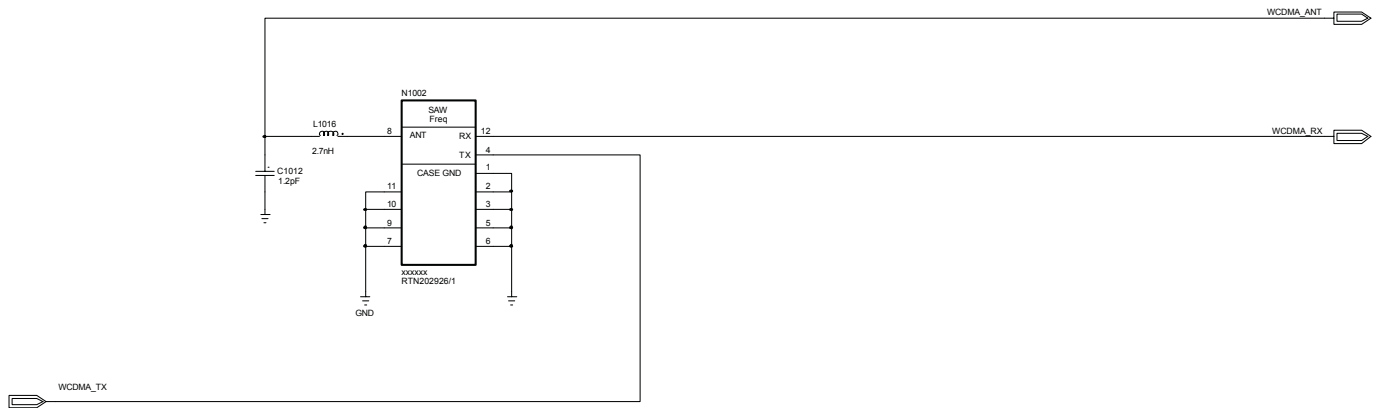

Made for	
RADIO Duplex	
RAY/UMTS Module	
Document Nr	Revision
1/1911 - ROA 128 1112/3	

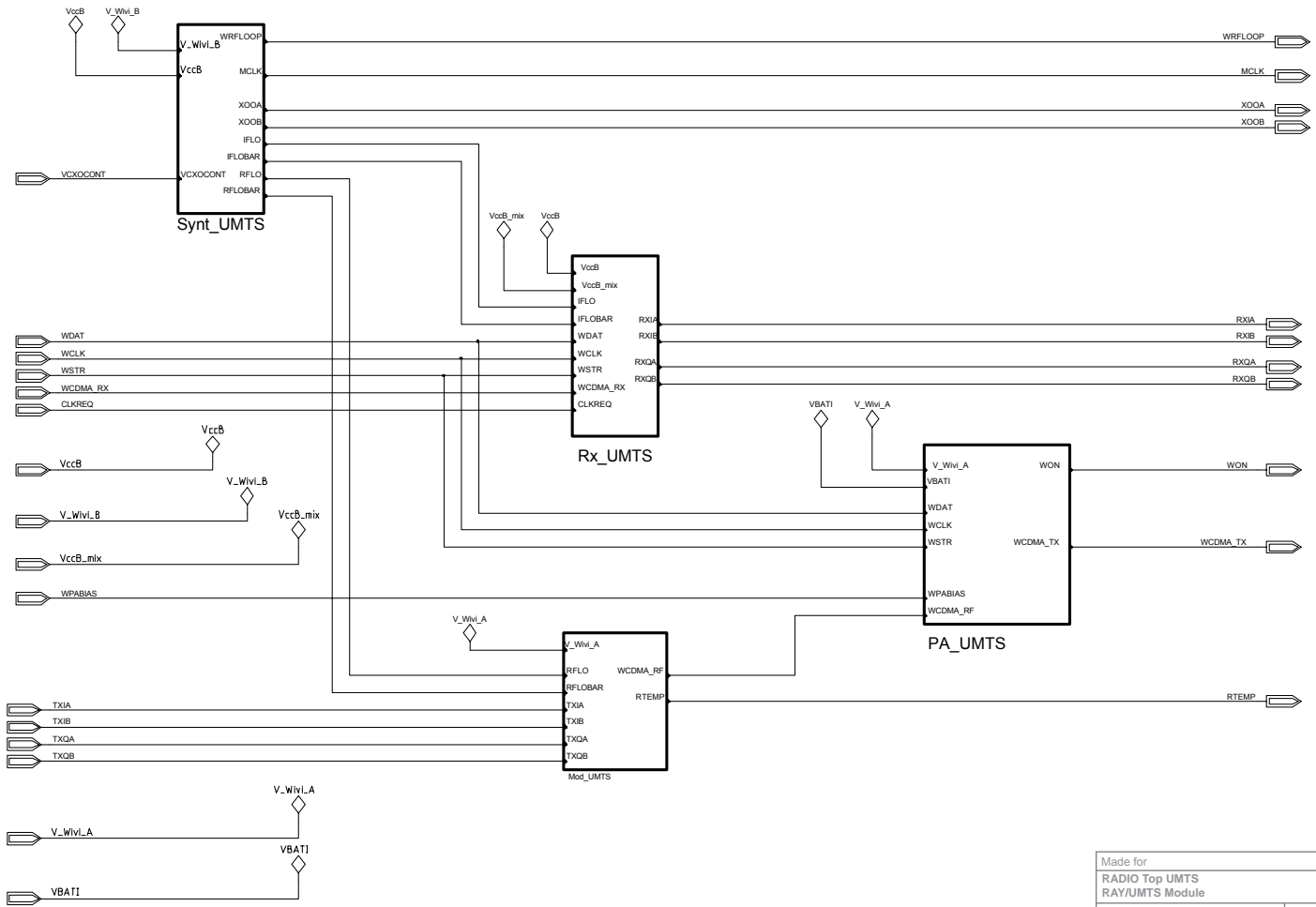

Made for	
RADIO Top UMTS RAY/UMTS Module	
Document Nr	Revision
1/1911 - ROA 128 1112/4	

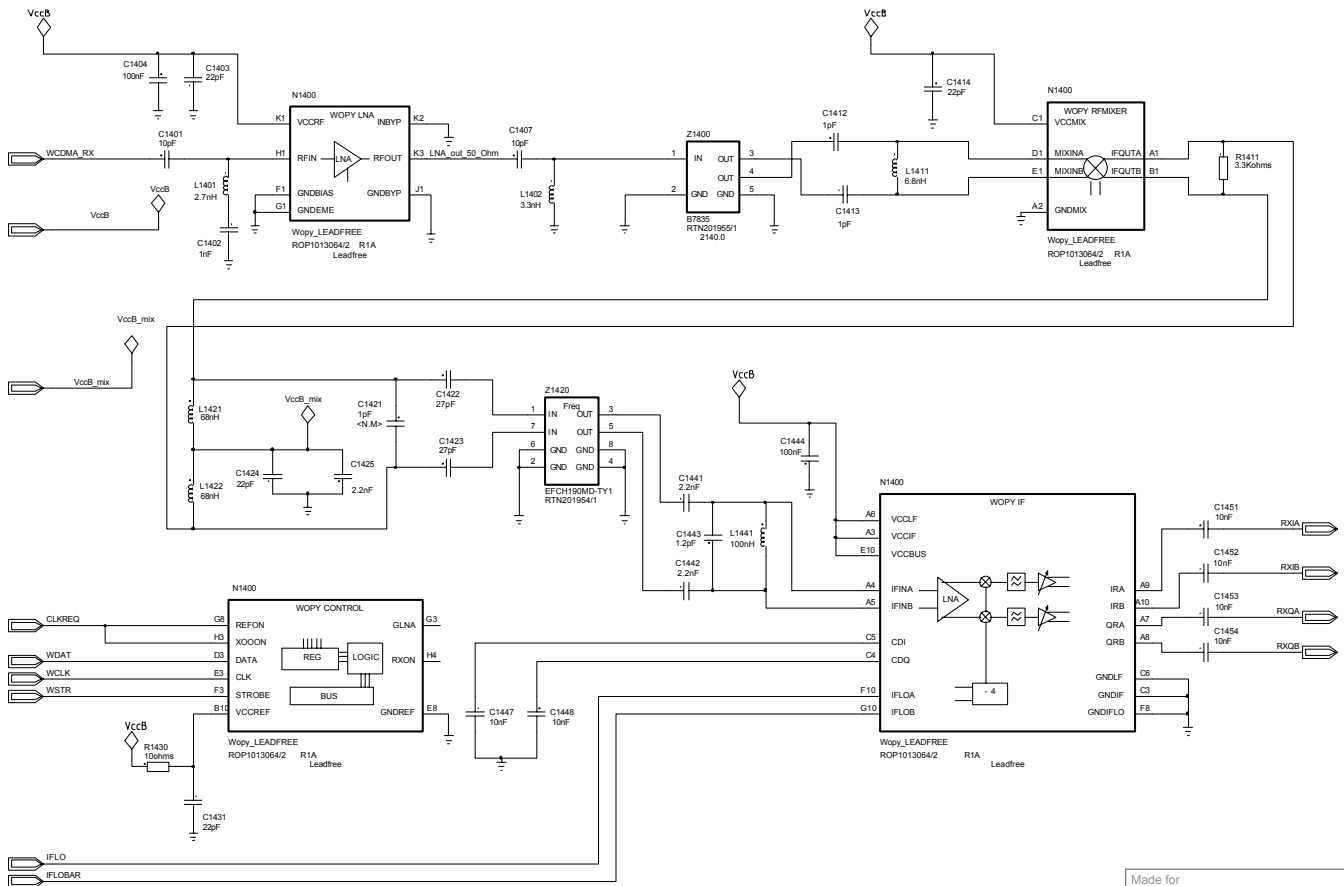

Made for	
RADIO Receiver UMTS RAY/UMTS Module	
Document Nr	Revision
1/1911 - ROA 128 1112/5	

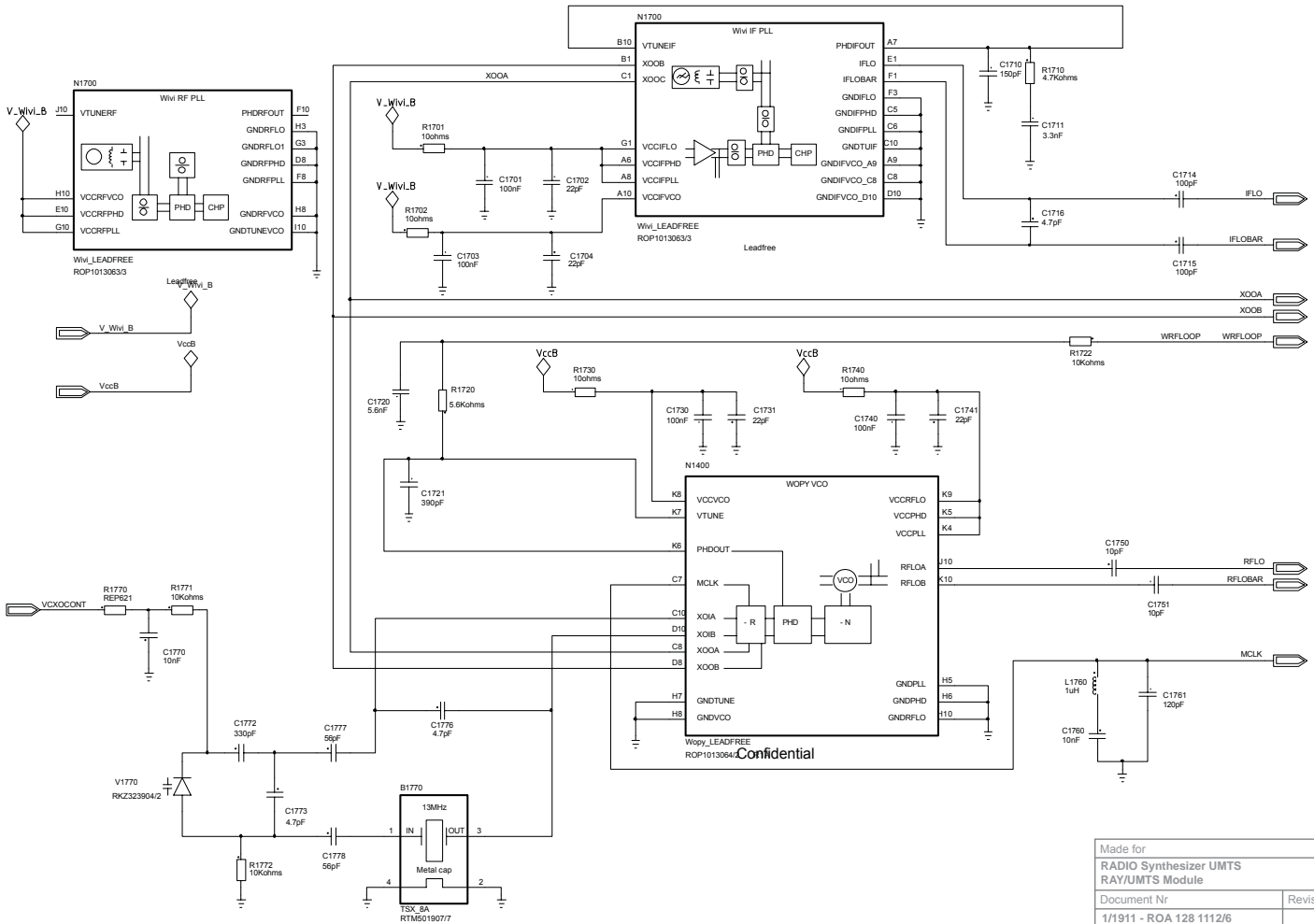

Made for	
RADIO Synthesizer UMTS RAY/UMTS Module	
Document Nr	Revision
1/1911 - ROA 128 1112/6	

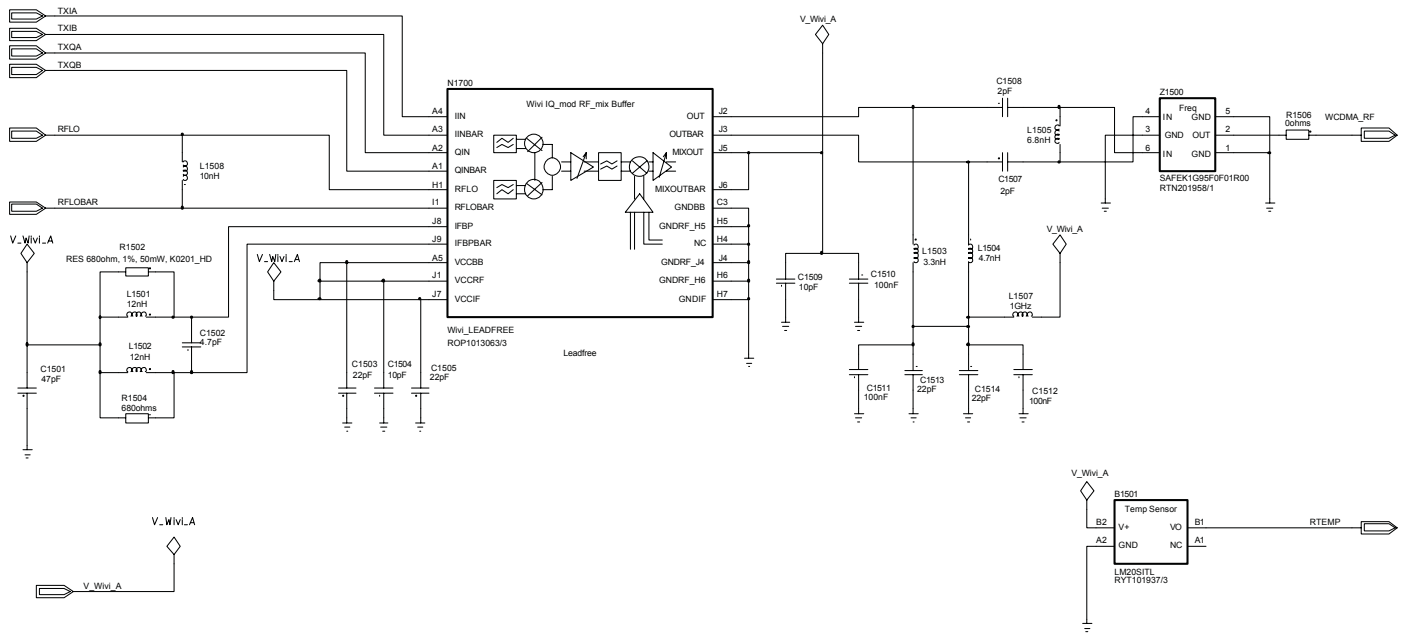

Made for	
RADIO Modulation UMTS RAY/UMTS Module	
Document Nr	Revision
1/1911 - ROA 128 1112/7	

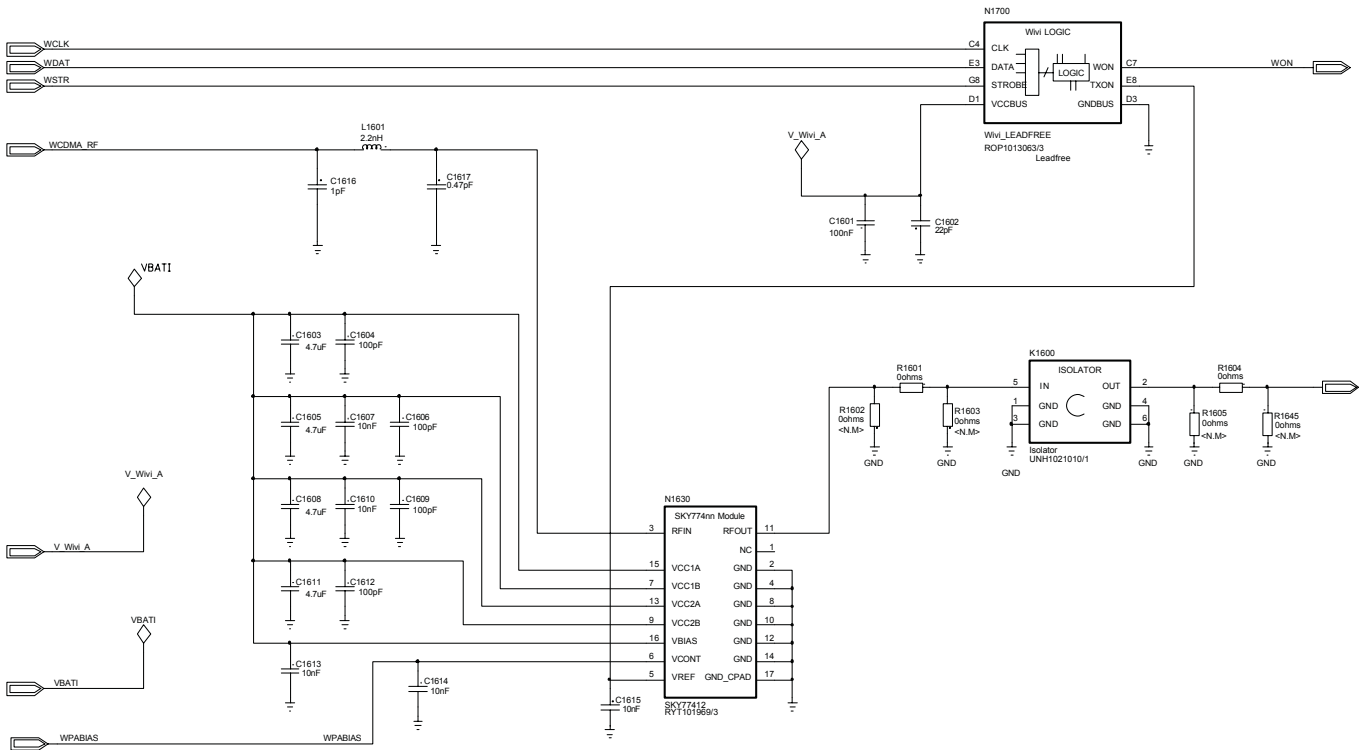

Made for	
RADIO Power Amplifier UMTS RAY/UMTS Module	
Document Nr	Revision
1/1911 - ROA 128 1112/8	

A1300 Marlin/GSM Module ROA1281640/Z

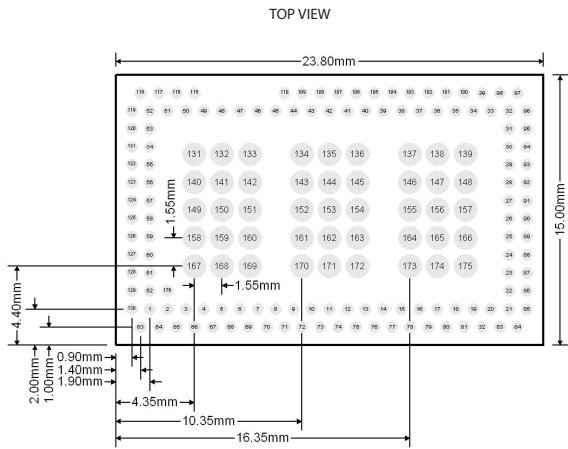

Note: Size 23.80 x 15.00 = Nominal PWB-size

Interface-pattern of the module:

Pin number	Copper pad	Solder mask opening
1-130	Round 0.67mm	Round 0.77mm
131-175	Round 1.35mm	Round 1.45mm

The interface has copper between pads, connected to signal: GND.

Pin number 176, are intended to be used as an "Pin-1"-marker

Recommended interface-pattern for the motherboard

Pin number	Copper pad	Solder mask opening
1-130	Round 0.57mm	Round ≤0.72mm
131-175	Round 1.25mm	Round ≤1.40mm

The outer layer using this footprint shall be filled with copper with good connection to GND. Isolation between signal copper and GND-plane filling: min 0.4mm

Pins / Signal cross-reference:

Pin number	Signal
1-2, 62-63, 130	VBATTi
8-9, 11-14, 16, 21, 28-29, 31-33, 37-38, 40-45, 47, 49-52, 54-61, 64-110, 115-129, 131-175, 176	GND
3	ANTSW3
4	ANTSW2
5	ANTSW1
6	ANTSW0
7	TXON
10	VccA
15	VLOOP
17	RADSTR
18	RADDAT
19	RADCLK
20	XOOB
22	XOOA
23	DIRMODCLK
24	MODA
25	MODB
26	MODC
27	MODD
30	CLKREQ
34	QDATA
35	DCLK
36	IDATA
39	VDIG
46	WCDMA_RF
48	ANT
53	VAPC

X001

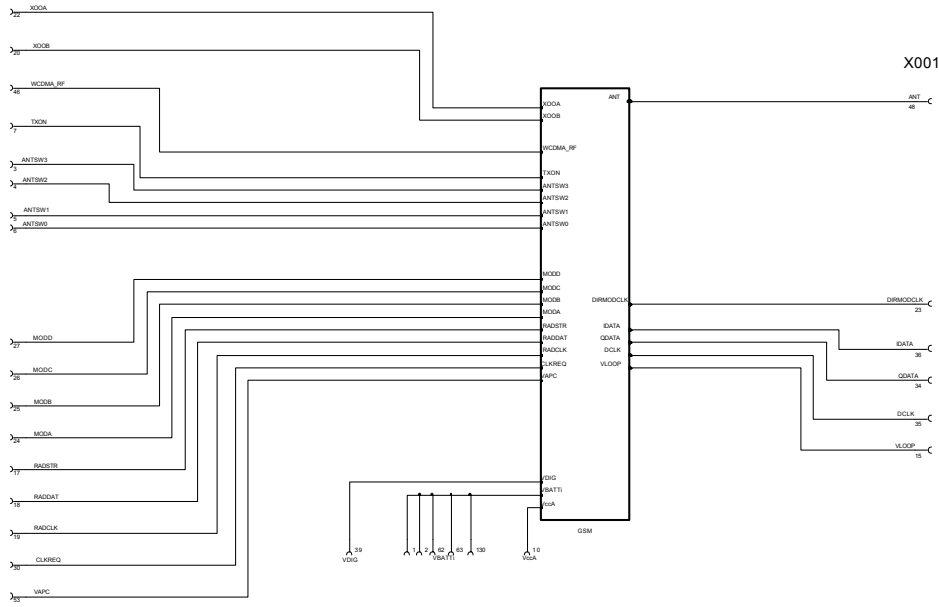

X001 - GND-intercae

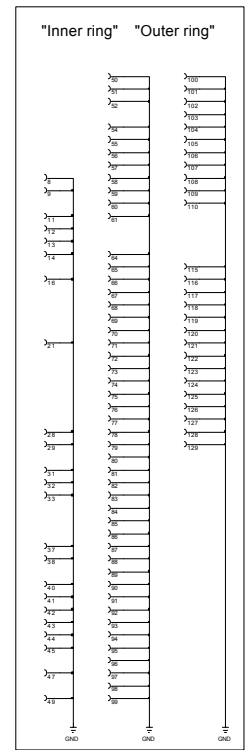

X001 - Heat-slag pins

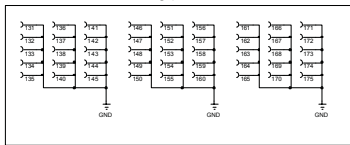

X001 - Pin1 marking

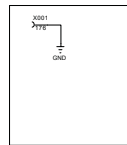

Shield can



Made for	
RADIO TOP	
Marlin/GSM-Module	
Document Nr	Revision
1911 - ROA 128 140/1	

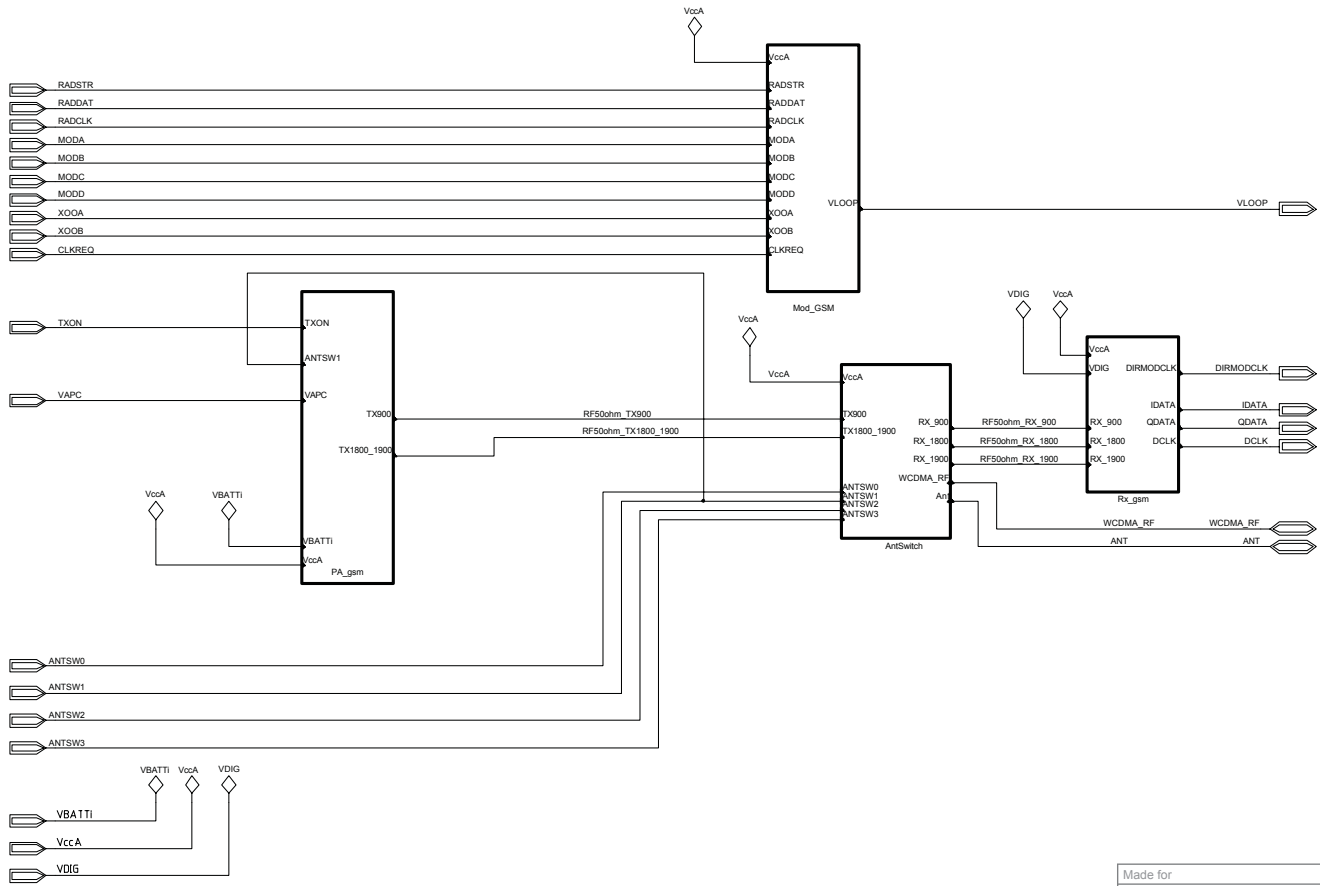

Made for	
RADIO TOP GSM Marlin/GSM-Module	
Document Nr	Revision
1911 - ROA 128 140/2	

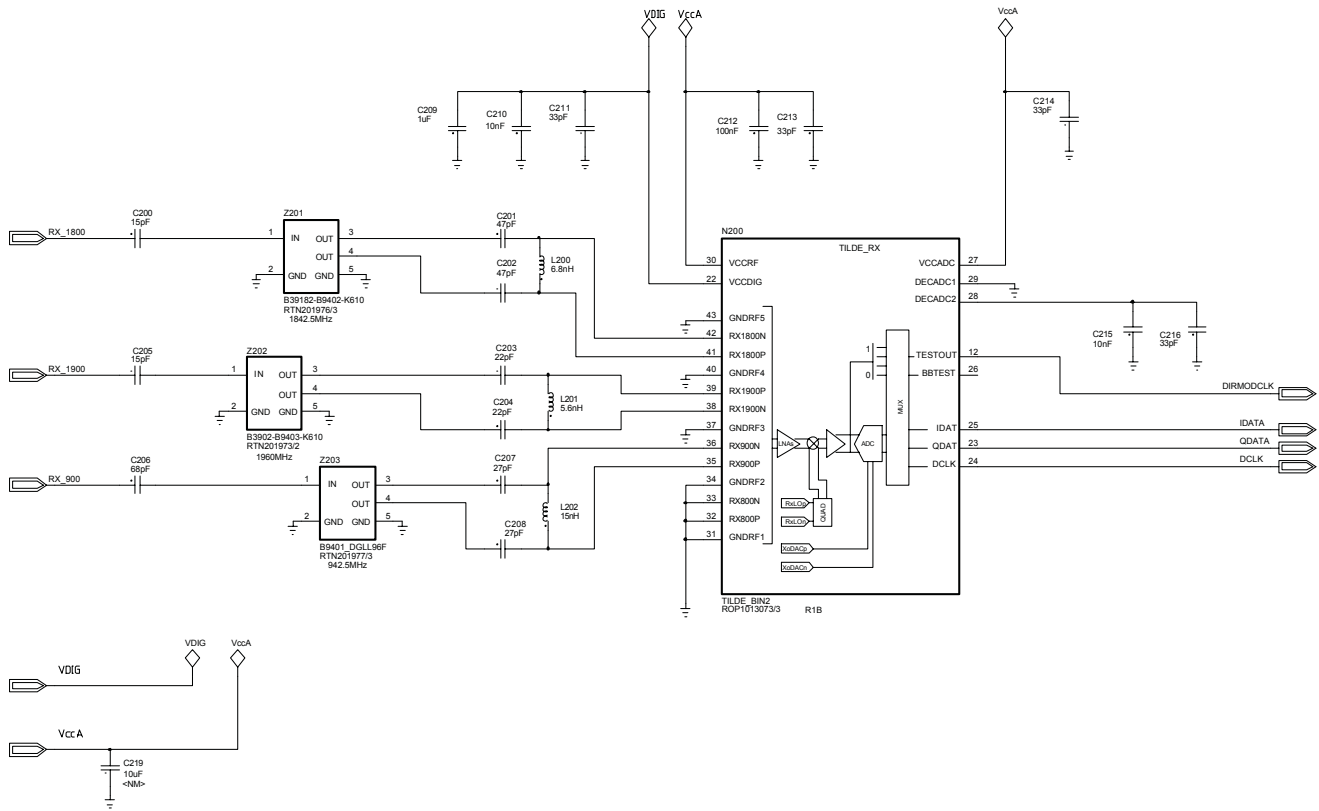

Made for	
RADIO Receiver GSM Marlin/GSM-Module	
Document Nr	Revision
1911 - ROA 128 140/3	

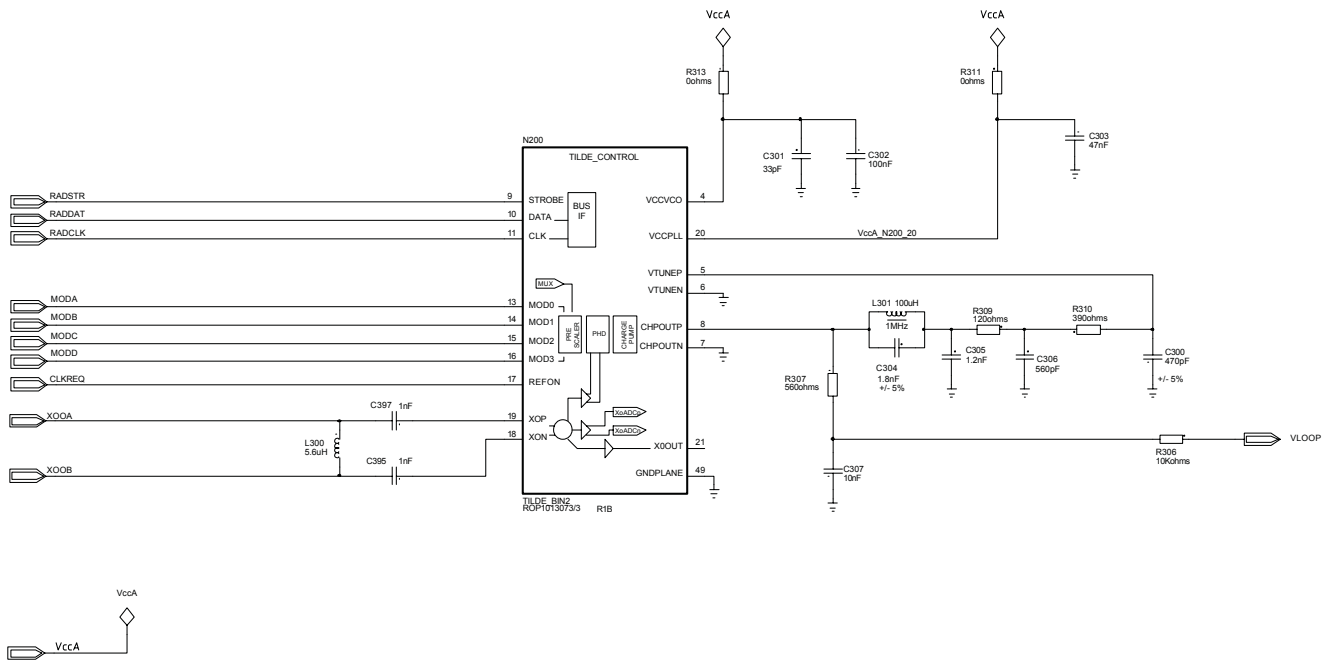

Made for	
RADIO Modulation GSM	
Marlin/GSM-Module	
Document Nr	Revision
1911 - ROA 128 140/4	

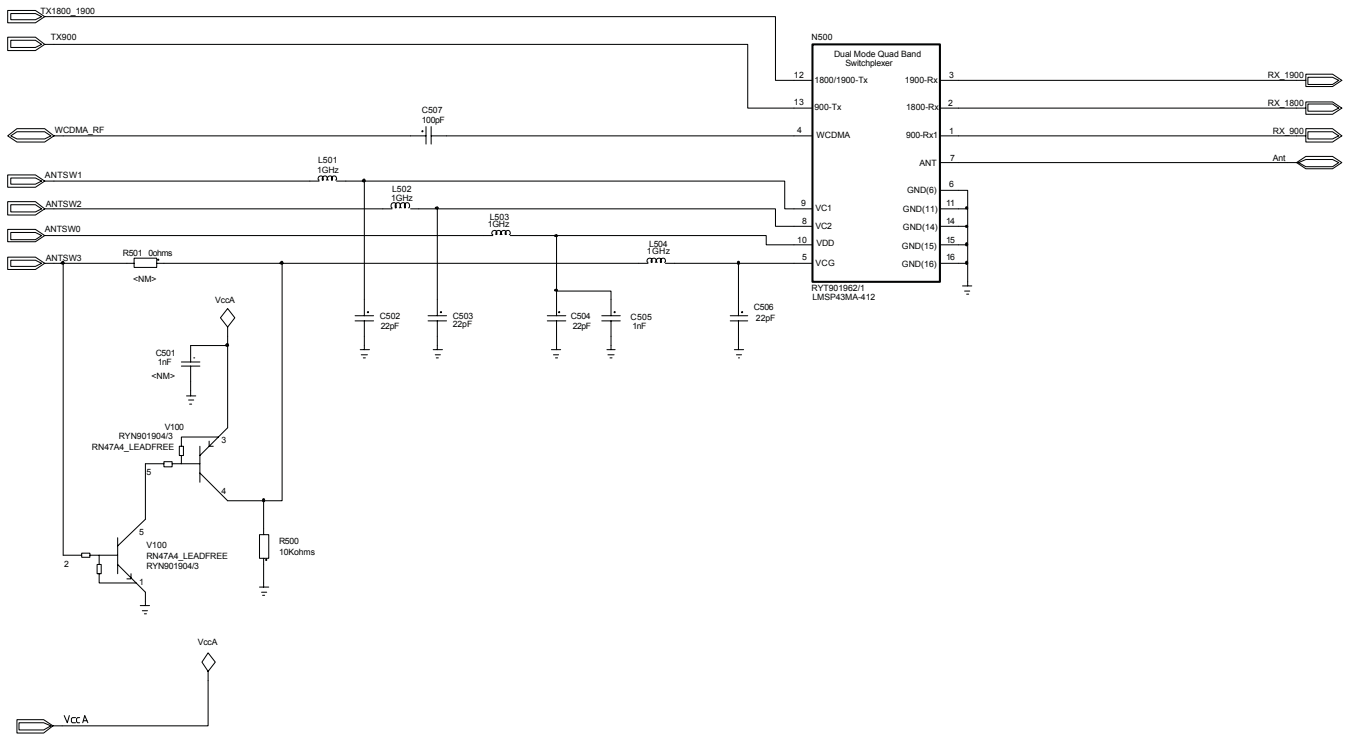

Made for	
RADIO Antenna Switch Marlin/GSM-Module	
Document Nr	Revision
1911 - ROA 128 140/6	

B2100 Crystal 32 768 Hz RTM501911/1

1. Dimensions

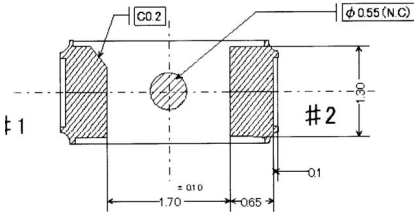
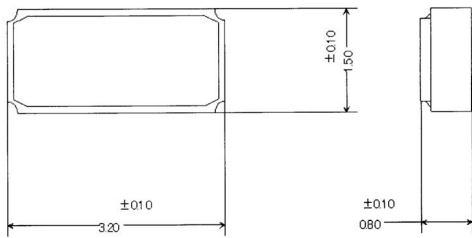

Package: Ceramco(Al₂O₃)
Terminal Au plate: 0.5 μm Min.
Lid: Glass

2. Internal Connection

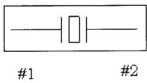

B4100 Microphone RF Improved RLC509427/3

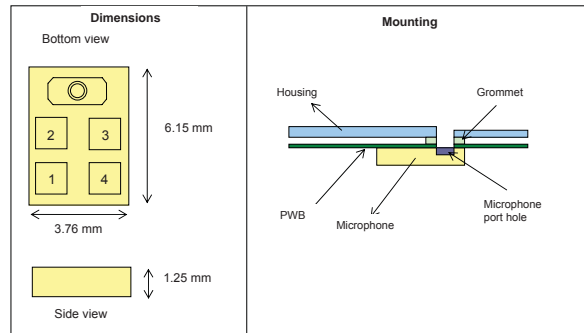

Connections

Terminal	Function
1	Output
2	Ground
3	Ground
4	Power

Electrical Characteristics

Test condition (V_s=2.0±0.05 V, R=2.0±0.05 kΩ, T_{amb} = 20±2 °C, R.H.=65±5 %).

Quantity	Symbol	Condition	Limits			Unit
			Min	Typ	Max	
Sensitivity	S	f=1kHz, P _{in} =1Pa, 0db=1V/Pa	-39	-42	-45	dB
Output impedance	Z _{OUT}	f=1kHz, P _{in} =0.1Pa			300	Ω
Current consumption	I	1.5 to 3.6 V			250	μA
S/N Ratio	S/N(A)	f=1kHz, P _{in} =1Pa, A-Weighted, 100 - 8000 Hz	55	59		dB
Decreasing voltage	ΔS	f=1kHz, P _{in} =0.1Pa, V _s =2.0 → 1.5V			-3	dB
Distortion	D	SPL = 110 dB, 0 dB = 20 μPa, f=1kHz			2%	THD
TDMA Disturbance Immunity	TDMA _{DI}	Under study				TBD
Supply Voltage			1.5		3.6	V

Test Circuit

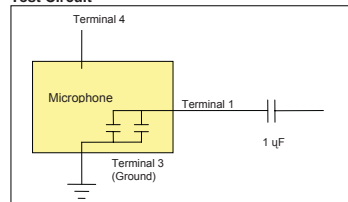

C2217 0.07F 3.3V Capacitor RJE3551335/7

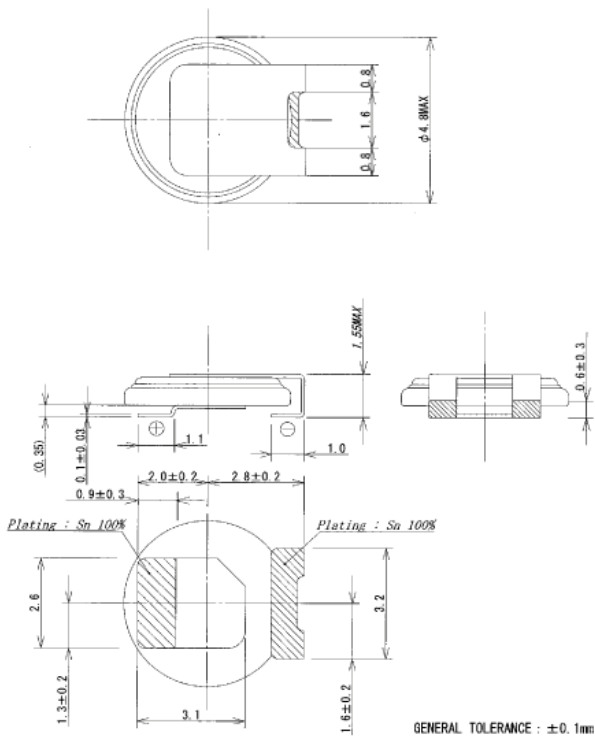

D1400 Microcircuit/Bluetooth E-STLC2500C4 RYT 123 923/2

STLC2500C Block Diagram

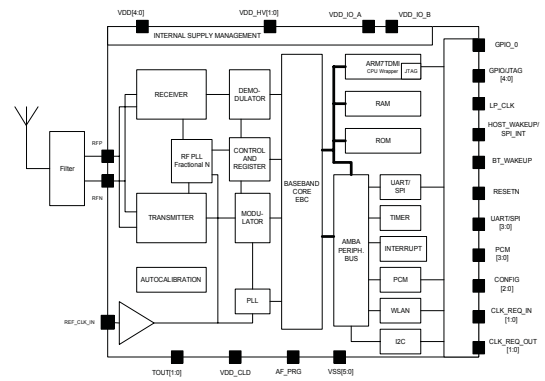

Pin out bottom view

	7	6	5	4	3	2	1
A	VDD_HV_A	TOUT_SP_GN	VSS_RF	RFN	RFP	VSS_RF	VDD_RF
B	VDD_DSM	VSS_ANA	TOUT_IN_GP	VSS_ANA	GPIO_16	GPIO_11	GPIO_9
C	VDD_IN	VSS_ANA	BT_WAKEUP	CLK_REQ_OUT_1	GPIO_8	PCM_SYNC	GPIO_10
D	VDD_CL	REF_CLK_IN	GPIO_0		RESET_N	PCM_A	PCM_CLK
E	VDD_CLD	CLK_REQ_IN_1	AF_PRG	VSS_DIG	VSS_DIG	CONFIG_1	PCM_B
F	HOST_WAKEUP /SPL_INT	UART_TXD /SPL_D0	UART_RXD /SPL_D1	UART_RTS /SPL_CS	VDD_IO_B	CONFIG_3	CONFIG_2
G	CLK_REQ_OUT_2	CLK_REQ_IN_2	VDD_IO_A	UART_CTS /SPL_CLK	LP_CLK	VDD_D	VDD_HV_D

D2301 512 MB NAND RYT118932/2

FBGA63 Connections, x8 devices (Top view through package)

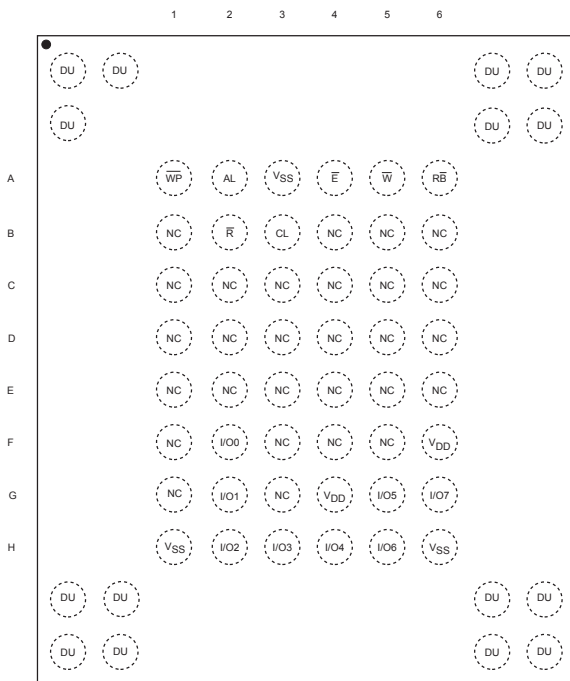

D2304 USB Transceiver and UART MUX RYT109913/1

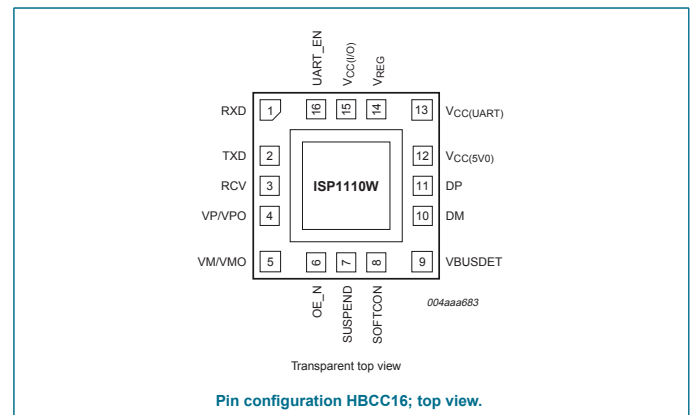

Pin configuration HBCC16; top view.

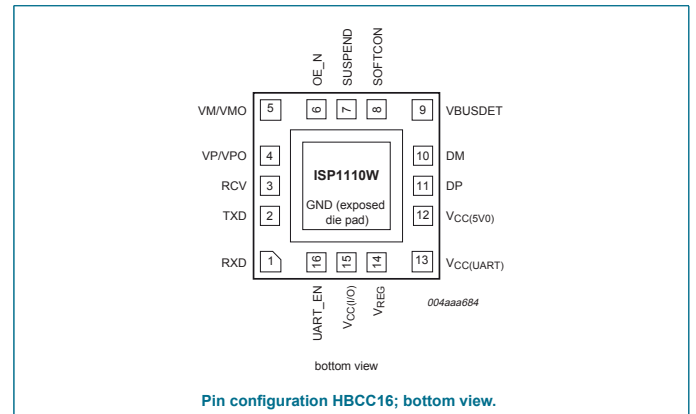

Pin configuration HBCC16; bottom view.

H2300 IrDA 6,7*2,45*1,7 RKZ923919/1

Dimensions in mm and tolerance 0.2 mm unless noted.

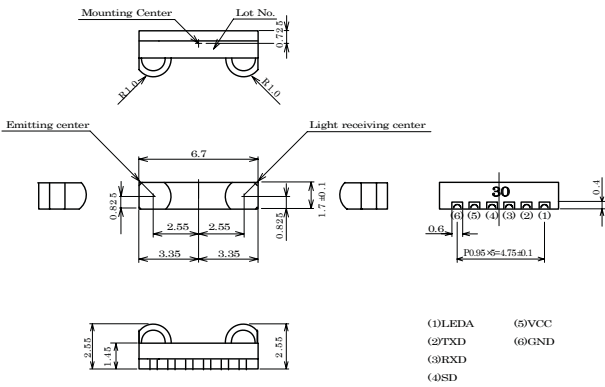

Soldering Pads for Reflow Soldering

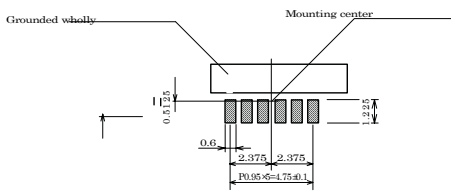

D3100, D3101 Octal Bus Transceiver RYT109915/1

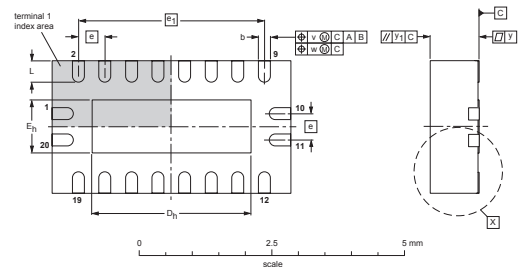
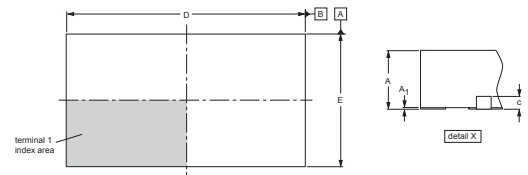
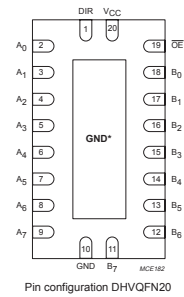

DIMENSIONS (mm are the original dimensions)

UNIT	A ⁽¹⁾ max	A ₁	b	c	D ⁽¹⁾	D _h	E ⁽¹⁾	E _h	e	e ₁	L	v	w	y	y ₁
mm	1	0.05 0.00	0.30 0.18	0.2	4.6 4.4	3.15 2.85	1.15 2.4	0.85	0.5	3.5	0.5 0.3	0.1	0.05	0.05	0.1

N2000 ASIC Vincenne 2 A07 1.8V Cu-Plug Thin Ni (Pb Free Package) ROP1013066/6

Pin Configuration Diagram

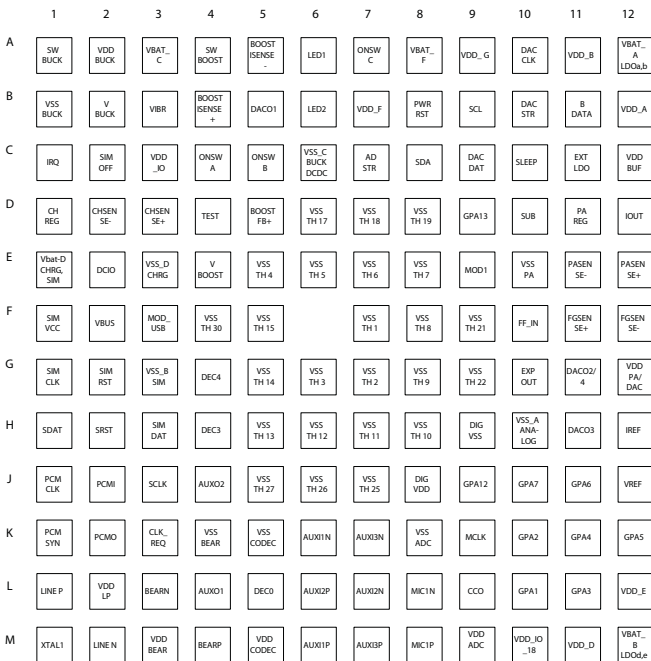

View of Pin Configuration Diagram (as seen from top of package)

N2200 LDO 1.3V RYT1137810/1

Pin Configurations

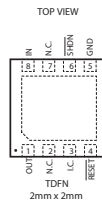

Pin Description

8-PIN TDFN (2mm x 2mm)	NAME	FUNCTION
8	IN	Regulator Input. Supply voltage can range from -1.2V to +3.0V. Bypass IN with at least a 1µF ceramic capacitor to GND (see the Capacitor Selection and Regulator Stability section).
—	GND	Ground. GND also functions as a heatsink. Solder to a large pad or circuit-board ground plane to maximize KOTD power dissipation.
5	GND	Ground
6	SHDN	Active-Low Shutdown Input. A logic-low reduces supply current to below 1µA. Connect to N or logic-high for normal operation.
4	RESET	Open-Drain, Active-Low Reset Output. RESET rises 100ms after the output has achieved regulation. RESET falls immediately if V _{OUT} drops below 82.5% of its nominal voltage, or if the device is shut down.
3	—	Internally Connected. Leave floating or connect to GND.
1	OUT	Regulator Output. Source up to 300mA. Bypass with a 4.7µF low-ESR ceramic capacitor to GND.
2,7	NC	No Connection. Not internally connected.
—	EP	Ground. EP also functions as a heatsink. Solder EP to a large pad or circuit-board ground plane to maximize TDFN power dissipation.

Package Information

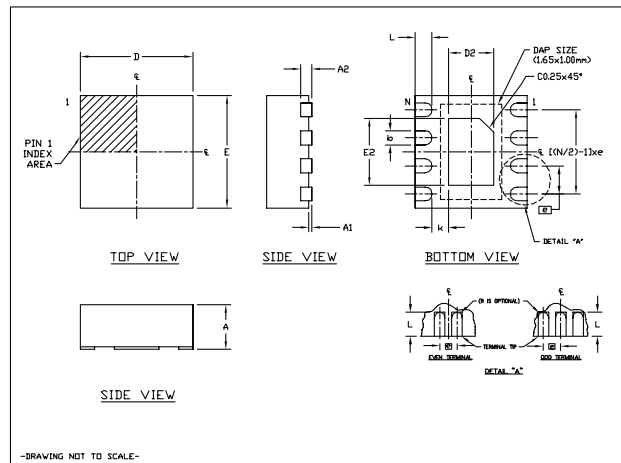

COMMON DIMENSIONS		
SYMBOL	MIN.	MAX.
A	0.70	0.80
D	1.50	2.10
E	1.90	2.10
A1	0.00	0.05
L	0.20	0.40
k	0.25	MIN.
A2	0.20	REF.

- NOTES:
 1. ALL DIMENSIONS ARE IN mm; ANGLES IN DEGREES.
 2. COPLANARITY APPLIES TO THE EXPOSED PAD AS WELL AS THE TERMINAL.
 COPLANARITY SHALL NOT EXCEED 0.08 mm.
 3. WARPAGE SHALL NOT EXCEED 0.08 mm.
 4. PACKAGE LENGTH/PACKAGE WIDTH ARE CONSIDERED AS SPECIAL CHARACTERISTICS.
 5. COMPLY TO JEDEC MO228 EXCEPT D2 AND E2 DIMENSIONS.
 6. "N" IS THE TOTAL NUMBER OF LEADS.
 7. NUMBER OF LEADS SHOWN ARE FOR REFERENCE ONLY.

N2202, N2203, N2204, N2210 Voltage Regulator 2.8V RYT1137824/1

PIN CONFIGURATION

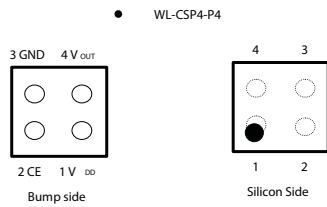

PIN DESCRIPTIONS

● R1115Z

Pin No.	Symbol	Description
1	V _{DD}	Input Pin
2	CE	Chip Enable Pin
3	GND	Ground Pin
4	V _{OUT}	Output pin

PACKAGE DIMENSIONS

Unit: mm

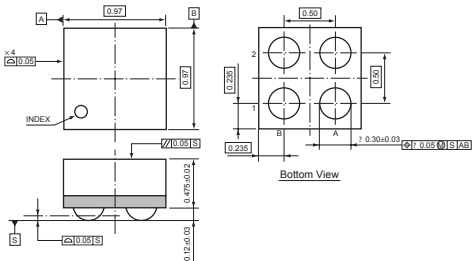

N2300 USB Filter Network RKZ923921/1

PACKAGE OUTLINE

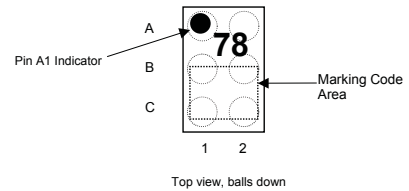
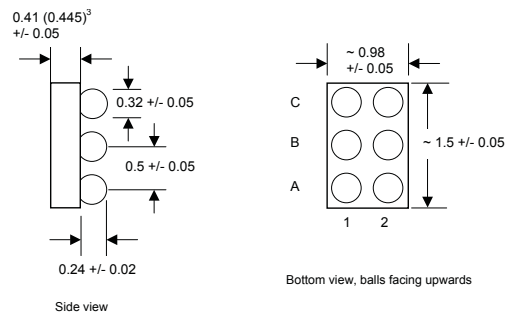

IP4078CX6/LF outline dimensions

Notes: (Unless otherwise specified)

1. Dimensions are in mm.
2. Solder ball diameter 0.30 mm before reflow
3. Back side protected by an additional 35µm polymer layer (optional)

N2600 Single Chip elec tuned FM Stereo Radio RYT109905/3

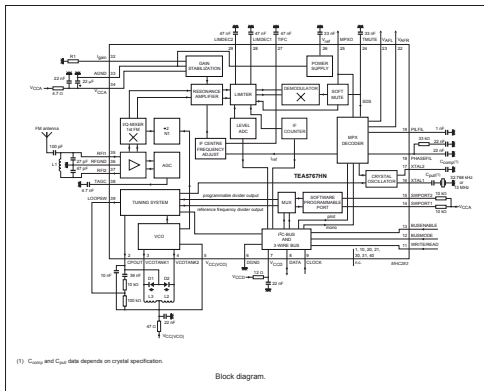
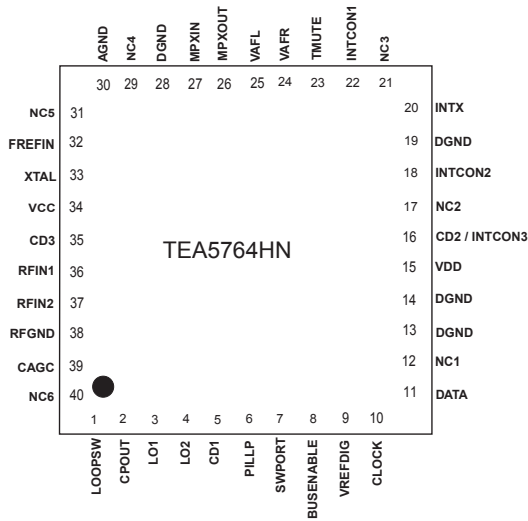

N3100 Dual Bilateral Analog Switch RYT109933/1

TOP VIEW

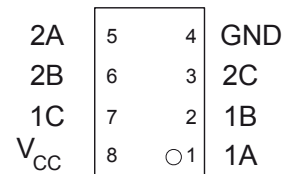

N4100 1W OPAMP Pb-free version RYT101947/2

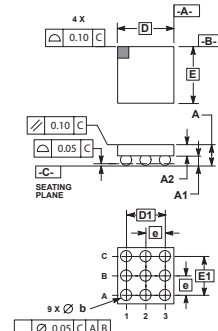
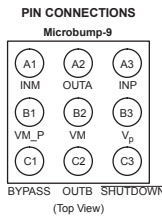

- NOTES:
1. DIMENSIONING AND TOLERANCING PER ANSI Y14.5M, 1982.
 2. CONTROLLING DIMENSION: MILLIMETERS.
 3. COPLANARITY APPLIES TO SPHERICAL CROWNS OF SOLDER BALLS.

MILLIMETERS		
DIM	MIN	MAX
A	0.550	0.650
A1	0.210	0.270
A2	0.130	0.190
D	3.450 BSC	
E	3.450 BSC	
b	0.200	0.340
e	0.500 BSC	
D1	1.000 BSC	
E1	1.000 BSC	

RECOMMENDED PCB FOOTPRINT

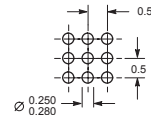

N4202 ASIC Tjatte 3 ROP1013074/1

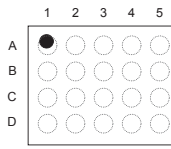

Top View (Bumps down)

PIN	DESCRIPTION	PIN	DESCRIPTION	PIN	DESCRIPTION	PIN	DESCRIPTION
A1	MICP _{int}	B1	VAD	C1	GND	D1	SP_ref
A2	MICN _{int}	B2	COO	C2	GND	D2	MICP
A3	SPL _{int}	B3	INTMIC _{int}	C3	GND	D3	MICN
A4	SPR _{int}	B4	GND	C4	GND	D4	SPL
A5	V _{MIC}	B5	INTMIC	C5	GND	D5	SPR

IP4027CX20/LF Pin configurations

Electrical diagram

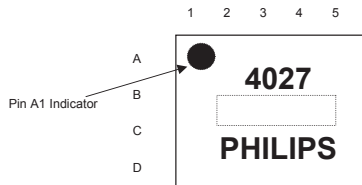
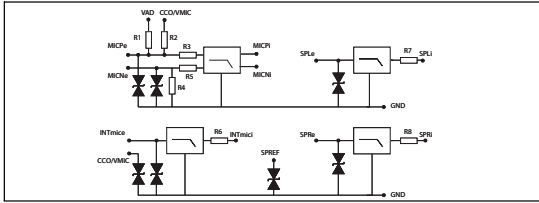

Top view, bump side down

S2500, S2502, S2503, S2507 Side Push Switch RMD10116/4

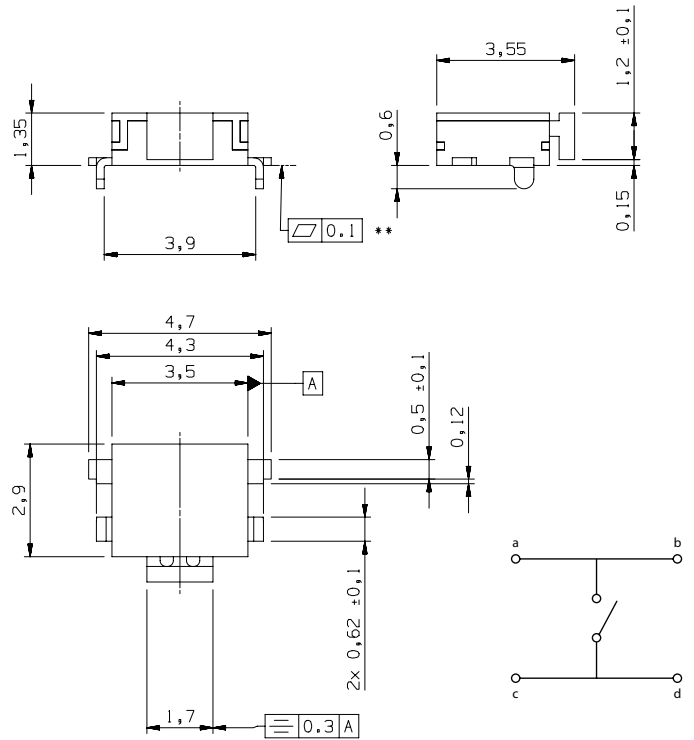

** - PSA / SPVR dimension

S2504 Joystick Switch SXA1092476

Circuit diagram

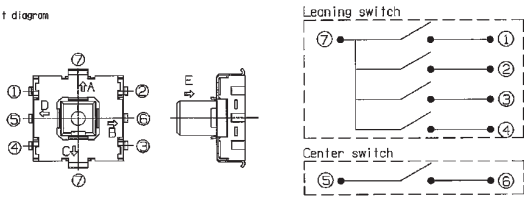

Direction	①	②	③	④	⑤	⑥	⑦	Remark
A	●	●				●	●	Leaning switch and Center switch
B		●	●			●	●	Leaning switch and Center switch
C			●	●		●	●	Leaning switch and Center switch
D	●			●		●	●	Leaning switch and Center switch
E					●	●		Only Center switch

S2505, S2506 A/B Key Switch RMD10147

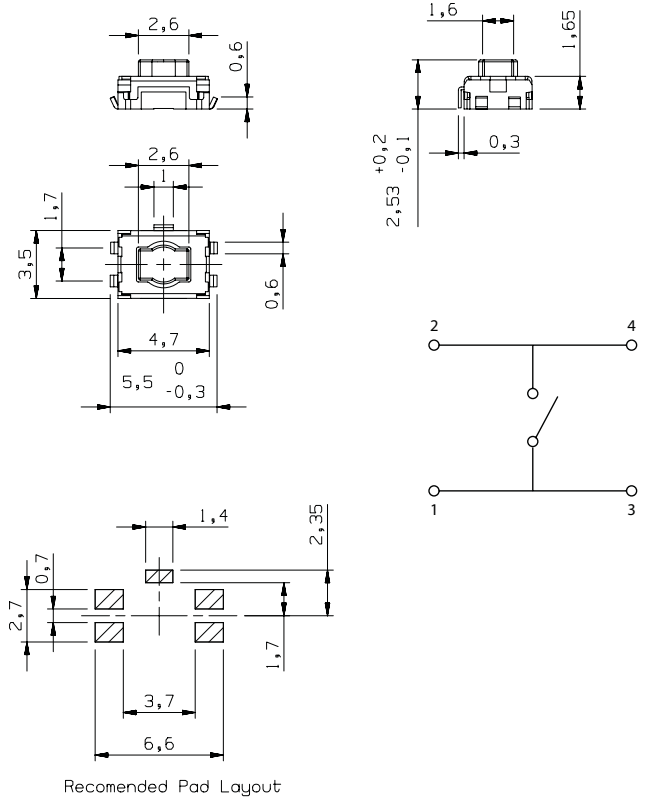

V2201 Diode, Schottky, Pb-free RKZ123918/1

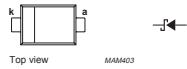

Marking code: L5.
The marking bar indicates the cathode.

Fig.1 Simplified outline (SOD523; SC-79) and symbol.

PIN	DESCRIPTION
1	cathode
2	anode

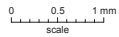
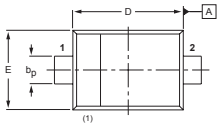
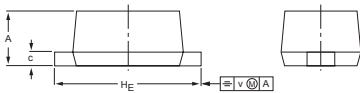

DIMENSIONS (mm are the original dimensions)

UNIT	A	b _p	c	D	E	H _E	v
mm	0.65 0.58	0.34 0.26	0.17 0.11	1.25 1.15	0.85 0.75	1.65 1.55	0.1

Note
1. The marking bar indicates the cathode.

V2202 P-channel MOSFET RYN122684/2

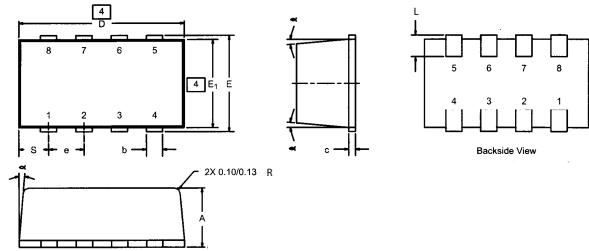

V2220 Dual MOSFET complementary N-P RYN123919/1

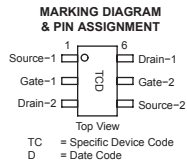
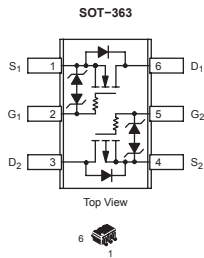

V2301, V2552 NPN Transistor, SOT723, R1=22k RYN121931/1

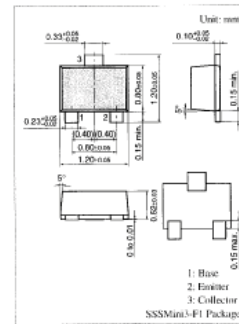

Marking Symbol: HE

Internal Connection

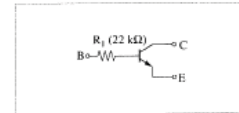

V2500, V4101 Dual ESD Protection Diode RKZ223914/1

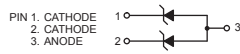

MARKING
DIAGRAM

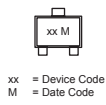

V2504 SWI X2 75V 2X75mA SC75 RKZ123904/1

PIN	DESCRIPTION
1	anode 1
2	anode 2
3	common cathode

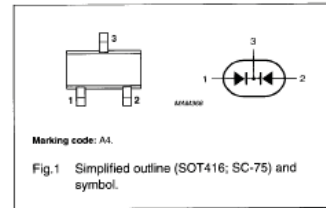

V3101 Transistor MOSFET N-Channel, SC88 RYN123915/1

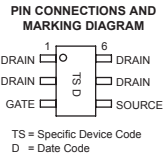
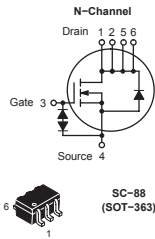

V3102 Schottky Diode RKZ323907/1

PIN	DESCRIPTION
1	cathode
2	anode

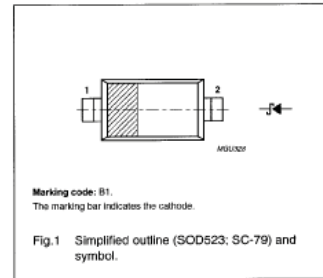

V3103 Dual N-Channel 2.5V MOSFET RYN901923/1

PIN	DESCRIPTION
1	cathode
2	anode

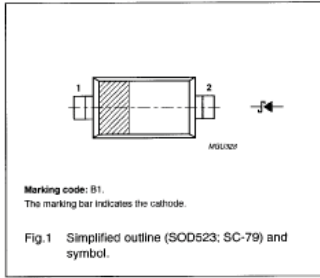

V3110 LED Red Side Fire RKZ433924/1

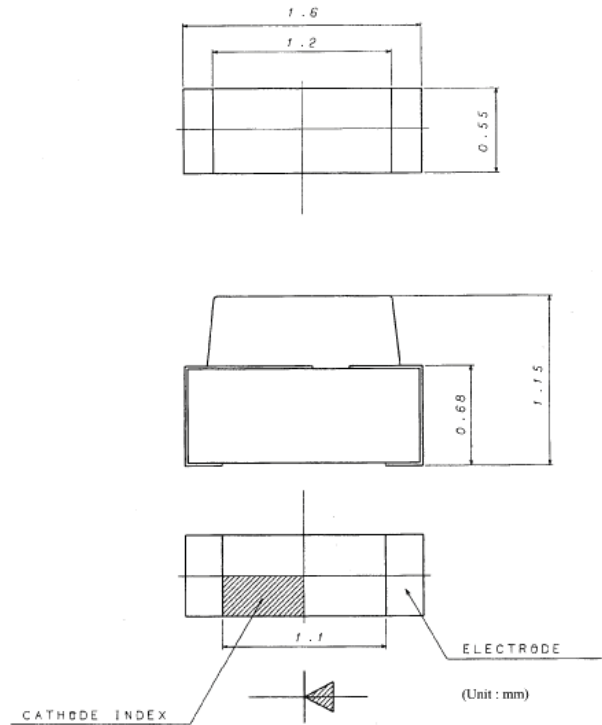

(Note) Tolerance is within ± 0.1 mm unless otherwise specified.

V3113 MOSFET, Dual P-Channel NoPb RYN122904/1

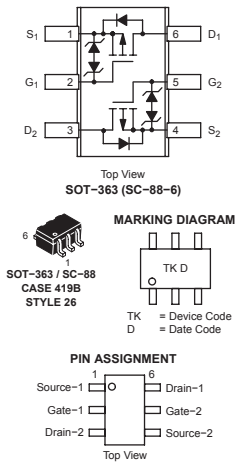

X1000 External Antenna Connector RPT79953

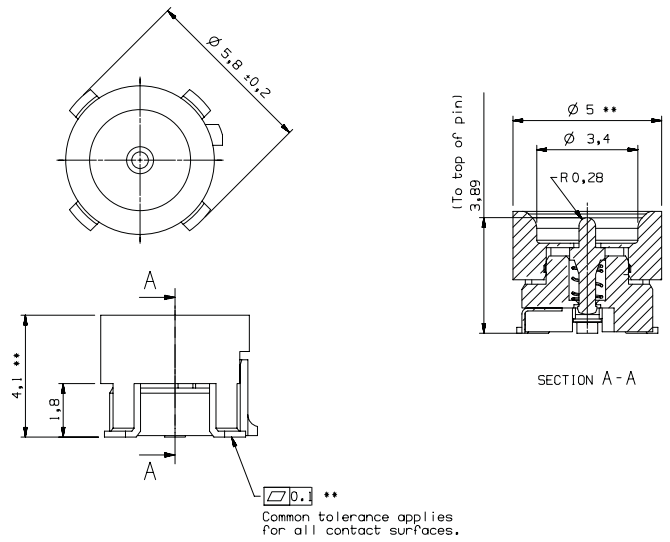

X1002 Internal Antenna Connector RPT79951

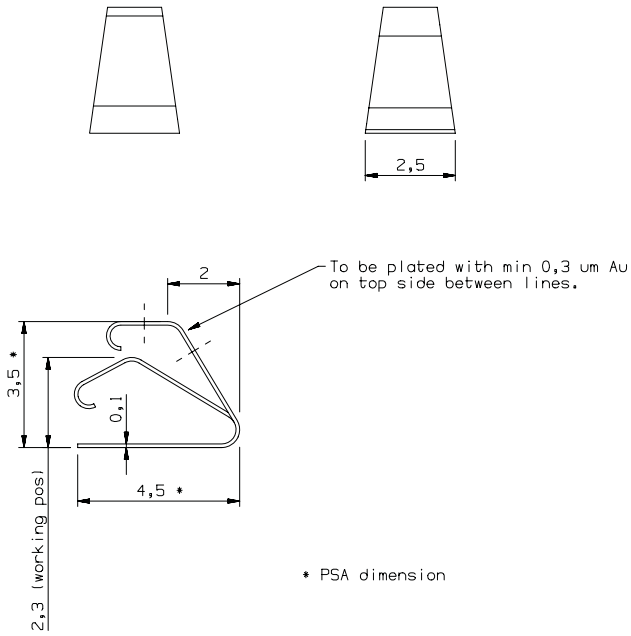

X2200 Battery Connector SND10622

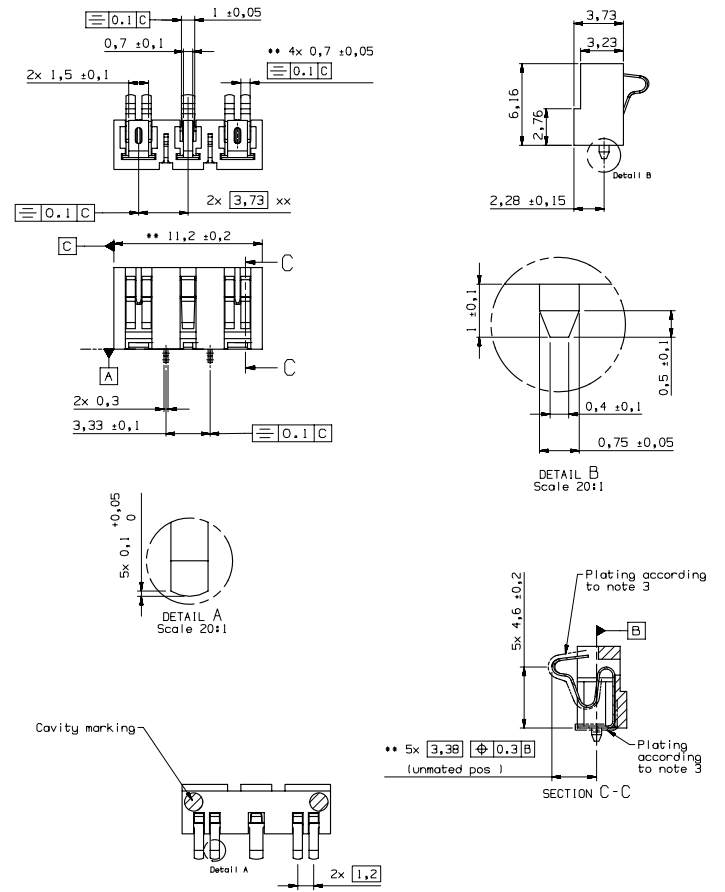

X2301 M2 Memory Card Reader RNK87147

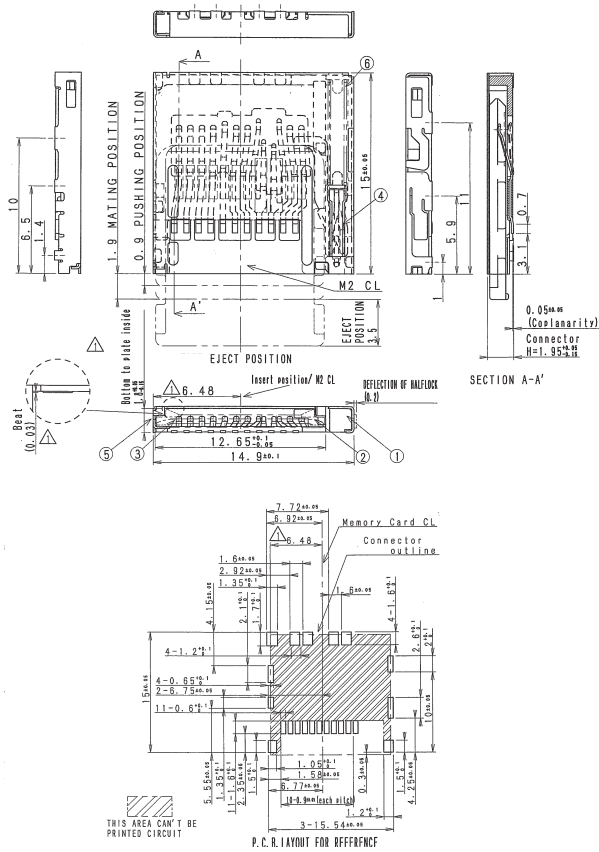

X2302 Sim Card Reader RNK87146

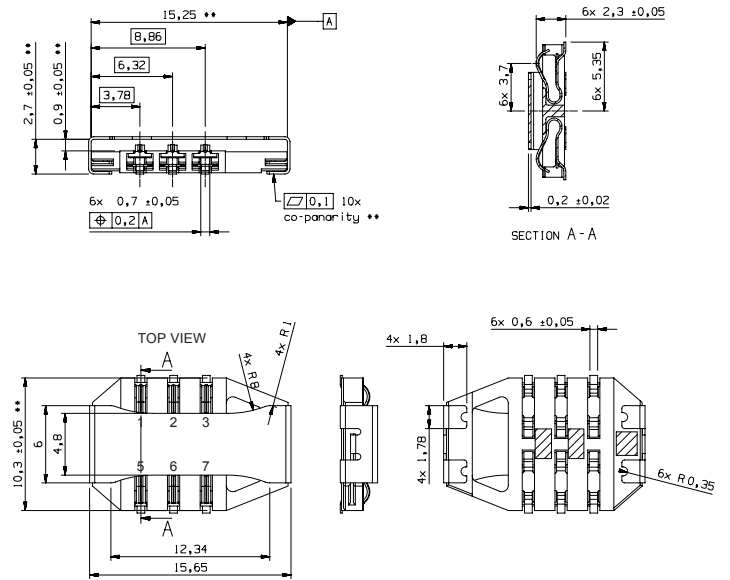

X2501 20 Pin BtB (female) RNV799009

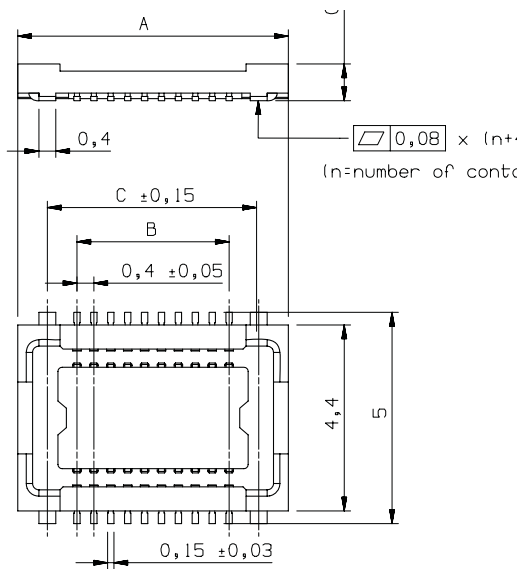

SEMC partnumber	Panasonic partnumber	Number of contacts/n	Corresponding part	A	B	C
RPV 799 44	AXK7L10227G	10	RPV 799 72	4,4	1,6	3,0
RNV 799 009	AXK7L20227G	20	RPV 799 61	6,4	3,6	5,0
RNV 799 94	AXK7L26227G	26	RPV 799 36	7,6	4,8	6,2
RNV 799 93	AXK7L30227G	30	RPV 799 92	8,4	5,6	7,0

X2505 30 Pin BtB (male) RNV79992

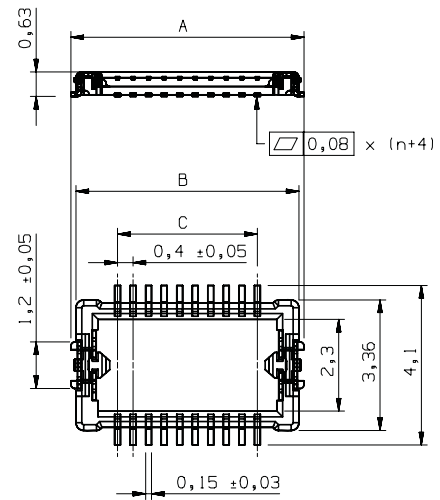

SEMC partnumber	Panasonic partnumber	Number of contacts/n	Corresponding part	A	B	C
RNV 799 72	AXKBL10125BG	10	RPV 799 44	4,0	3,74	1,6
RPV 799 61	AXKBL20125BG	20	RNV 799 009	6,0	5,74	3,6
RPV 799 36	AXKBL26125BG	26	RNV 799 94	7,2	6,94	4,8
RNV 799 92	AXKBL30125BG	30	RNV 799 93	8,0	7,74	5,6

X2510 Socket VGA Camera RNV799015

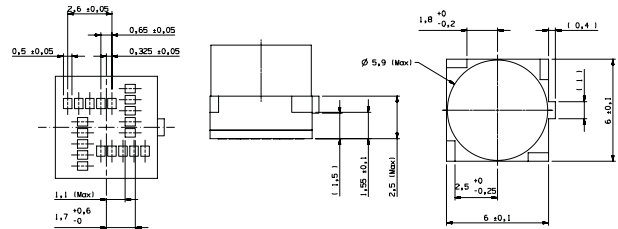

X2550 FPC 10 Pin (DDK) RNV799019/10

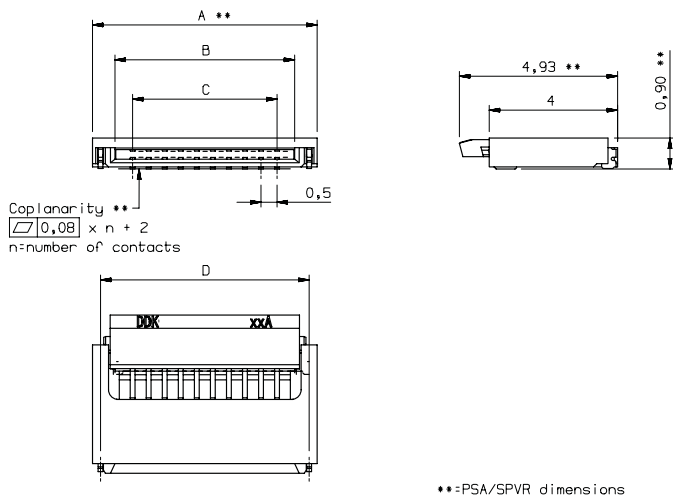

SEMC partnumber	DDK partnumber	Number of contacts/n	A	B	C	D
RNV 799 019/10	FF14-10A-R12B	10	7,00	5,60	4,50	6,50

X3102 26 Pin BtB (female) RNV79994

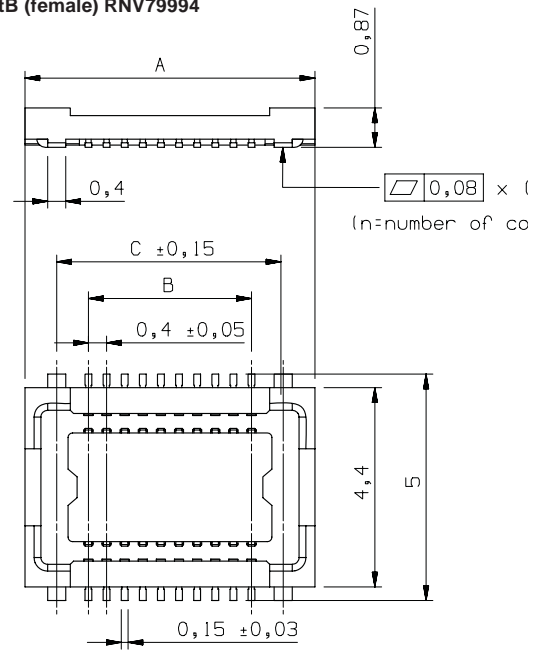

SEMC partnumber	Panasonic partnumber	Number of contacts/n	Corresponding part	A	B	C
RPV 799 44	AXK7L10227G	10	RNV 799 72	4,4	1,6	3,0
RNV 799 009	AXK7L20227G	20	RPV 799 61	6,4	3,6	5,0
RNV 799 94	AXK7L26227G	26	RPV 799 36	7,6	4,8	6,2
RNV 799 93	AXK7L30227G	30	RNV 799 92	8,4	5,6	7,0

Keyboard K800

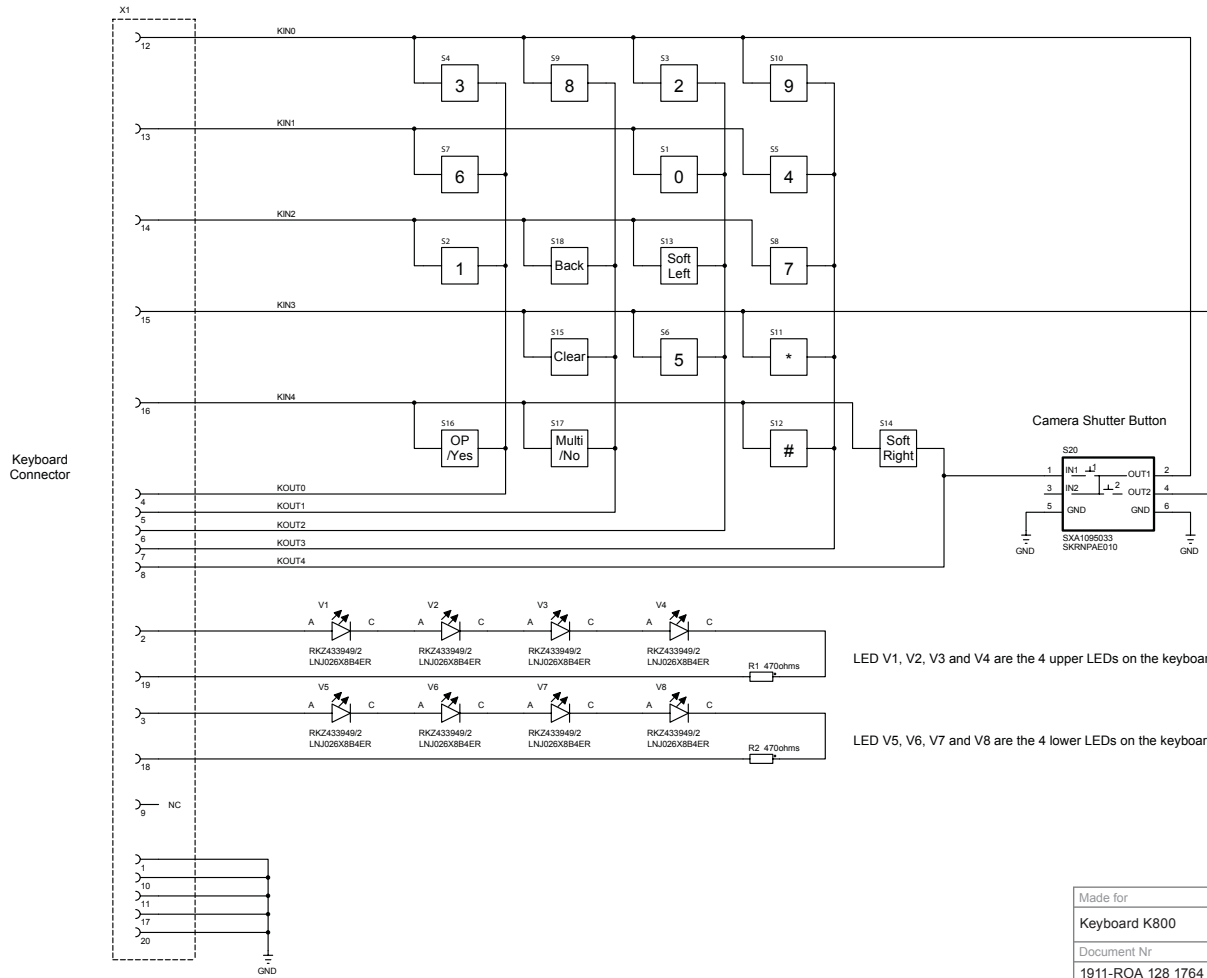

LED V1, V2, V3 and V4 are the 4 upper LEDs on the keyboard.
LED V5, V6, V7 and V8 are the 4 lower LEDs on the keyboard.

Made for	
Keyboard K800	
Document Nr	Revision
1911-ROA 128 1764	

Keyboard K810

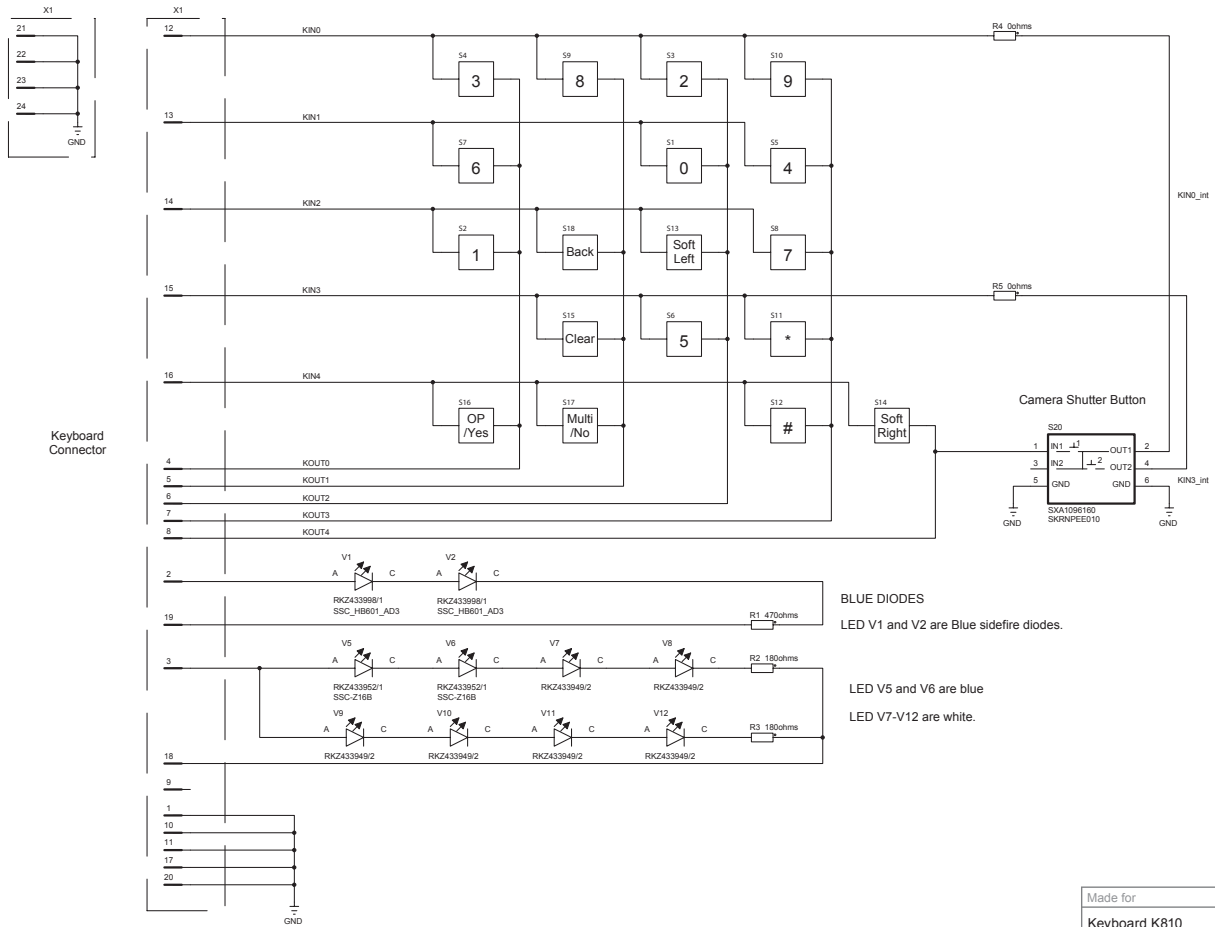

BLUE DIODES
LED V1 and V2 are Blue sidfire diodes.

LED V5 and V6 are blue
LED V7-V12 are white.

Made for	
Keyboard K810	
Document Nr	Revision
1911-ROA 128 2402	

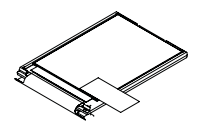
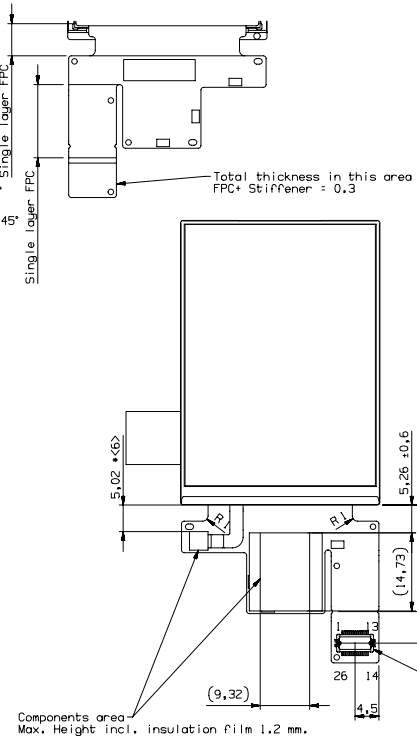
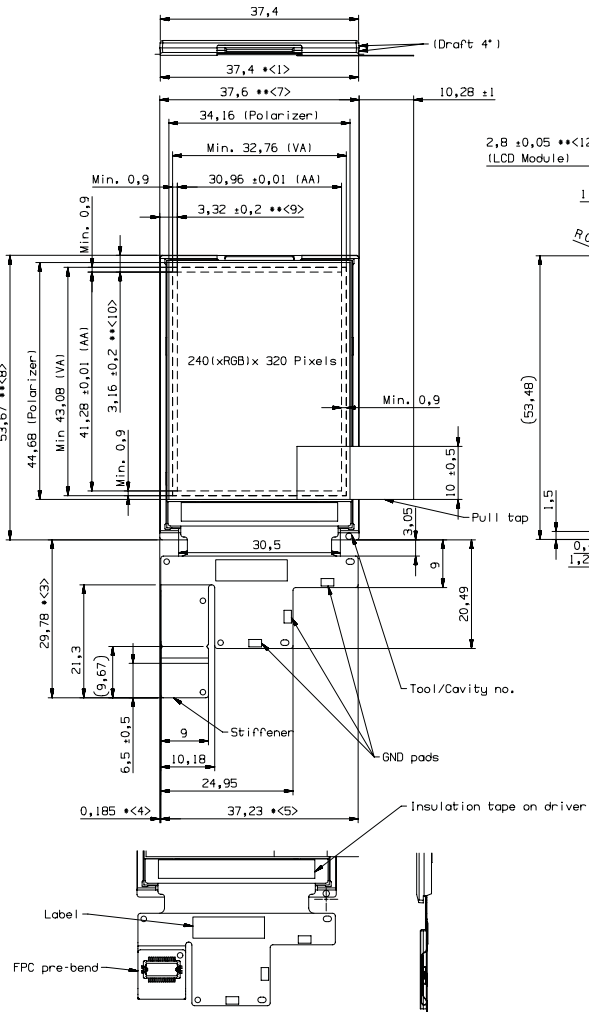

No	Signal	I/O
1	ANODE	-
2	NC	-
3	VDD	-
4	VDD10	-
5	VSS	-
6	RESET	!
7	CS	!
8	WR	!
9	DC	I/O
10	D2	I/O
11	D4	I/O
12	D6	I/O
13	VSS	-
14	VSS	-
15	D7	I/O
16	D5	I/O
17	D3	I/O
18	D1	I/O
19	RD	!
20	RS	!
21	Vsync	0
22	VSS	-
23	NC	-
24	VDD	-
25	NC	-
26	CATHODE	-

General Tolerances	
Also valid for referenced 3D model	
Basic	Tol.
01 - 10	±0,05
101 - 25	±0,07
251 - 70	±0,10
> 70	±0,15
Angles: ±0,5°	

Made for	
Display	
Document Nr	Revision
1_1301-RNH942268ENB	

VGA Camera KNC 201 16

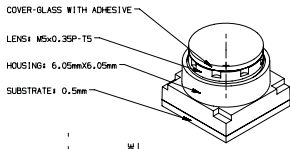

THIS VIEW SHOWS SUBSTRATE AND SENSOR ONLY

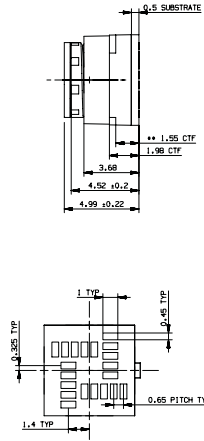
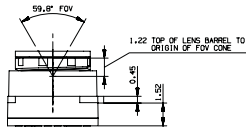
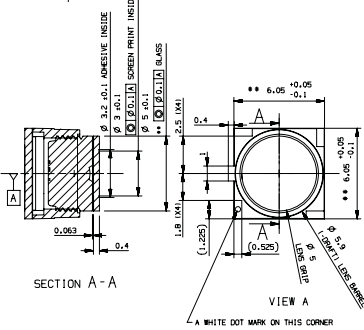
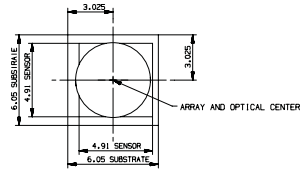

SOCKET CONTACT PADS
NICKEL & GOLD PLATED COPPER

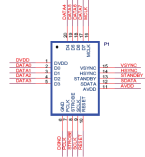

Pin#	Pin name	Description	Type	State After reset	State in standby
1	DVDD	Digital power	S	VDD	VDD
2	DOUT0	Pixel Data Output bit 0 (LSB)	O	Default Value	High-Z
3	DOUT1	Pixel Data Output bit 1	O	Default Value	High-Z
4	DOUT2	Pixel Data Output bit 2	O	Default Value	High-Z
5	DOUT3	Pixel Data Output bit 3	O	Default Value	High-Z
6	GND	Ground	S	GND	GND
7	PCLK	Pixel clock output	O	Default Value	High-Z
8	STRB	Frame strobe	O	Default Value	High-Z
9	SCLK	Television Serial interface Clock	I	Default Value	SCLK
10	RESET_BARGE	Asynchronous reset, active low	I	Low	High
11	AVDD	Analog power	S	VDD	VDD
12	SDATA	Television Serial interface Data I/O	I/O	Default Value	SDATA
13	STANDBY	Standby mode setting	I	Low	High
14	HSYNC	Active high, indicates active frame	O	Default Value	High-Z
15	VSYNC	Active high, indicates active frame	O	Default Value	High-Z
16	MCLK	Master clock in sensor	I	MCLK	MCLK
17	DOUT7	Pixel Data Output bit 7	O	Default Value	High-Z
18	DOUT8	Pixel Data Output bit 8 (MSB)	O	Default Value	High-Z
19	DOUT5	Pixel Data Output bit 5	O	Default Value	High-Z
20	DOUT4	Pixel Data Output bit 4	O	Default Value	High-Z

Camera Module KNC 201 25

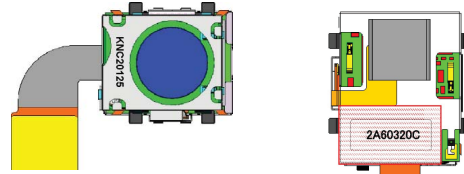

Pin#	Pin name	Description	I/O	State @ Reset	State @ Power off	State @ Standby
1	AF_GND	Autofocus ground	-	-	-	-
2	GND	Ground	-	-	-	-
3	VDD_AF	Voltage supply for autofocus (2.7 V)	-	-	-	-
4	SCL	I-C serial bus clock	I/O	HiZ	HiZ	Active
5	GND	Ground	-	-	-	-
6	SDA	I-C serial bus data	I/O	HiZ	HiZ	Active
7	VDD_SA	Voltage supply for analog part of sensor (2.7 V)	-	-	-	-
8	VSYSN	Vertical synchronization signal	O	Low	HiZ	HiZ
9	GND	Ground	-	-	-	-
10	HSYSN	Horizontal synchronization signal	O	Low	HiZ	HiZ
11	VDD_IO	Voltage supply for DSP I/O (2.7 V)	-	-	-	-
12	XRST	System reset	I	-	-	-
13	TRIG	Interrupt signal	O	Low	HiZ*	HiZ*
14	CAPTSTRB	Capture/strobe signal	O	Low	HiZ*	HiZ*
15	GND	Ground	-	-	-	-
16	D[6]	Digital video data	O	Low	HiZ	HiZ
17	D[7]	Digital video data (MSB)	O	Low	HiZ	HiZ
18	D[4]	Digital video data	O	Low	HiZ	HiZ
19	D[5]	Digital video data	O	Low	HiZ	HiZ
20	D[2]	Digital video data	O	Low	HiZ	HiZ
21	D[3]	Digital video data	O	Low	HiZ	HiZ
22	D[0]	Digital video data (LSB)	O	Low	HiZ	HiZ
23	D[1]	Digital video data	O	Low	HiZ	HiZ
24	GND	Ground	-	-	-	-
25	VDD_SD	Voltage supply for digital part of sensor (1.8 V)	-	-	-	-
26	MCK	System clock input	I	-	-	-
27	DCK	Digital video data clock	O	Low	HiZ	HiZ
28	GND	Ground	-	-	-	-
29	GND	Ground	-	-	-	-
30	VDD_L	Voltage supply for DSP core (1.2 V)	-	-	-	-

Xenon Flash Module RKZ 433 970

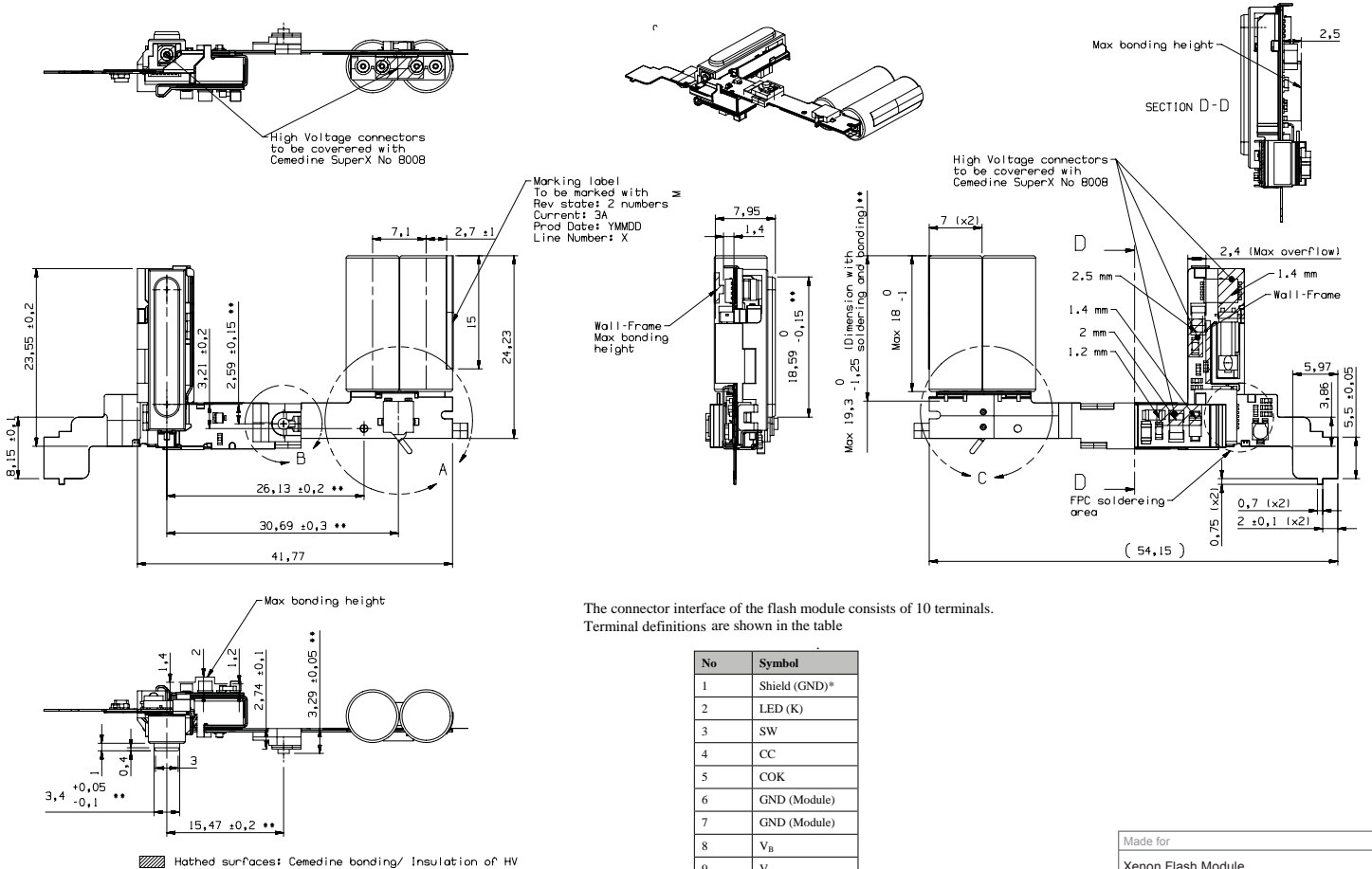

The connector interface of the flash module consists of 10 terminals. Terminal definitions are shown in the table

No	Symbol
1	Shield (GND)*
2	LED (K)
3	SW
4	CC
5	COK
6	GND (Module)
7	GND (Module)
8	V _B
9	V _B
10	TRIG

Made for	
Xenon Flash Module	
Document Nr	Revision
1301-RKZ433970ENF	

SI - Can't Power On

Symptom:

Before doing any electrical / mechanical repair on "Can not Power on", first secure that the problem is not caused by software!

Attach a charger; if the charging indicator LED is blinking only approx. 4-7 times before it stops, the problem is caused by software!

Important: You might have to try attaching the charger up to 5 times in order to be sure you don't have symptom.

IF THE UNIT'S CHARGING INDICATOR BLINKS ONLY APPROX. 4-7 TIMES YOU SHALL NOT REPLACE ANY COMPONENTS!

The problem is caused by corrupt software.

Please see solutions Pre-config (1) and Pre-config (2) below for this type of problems.

Pre-config (1) (see old SI for more details)

ONLY applicable if you have a K800 or K790 produced 2006 otherwise go directly to Pre-configuration 2 section.

Log on to EMMA III as usual.

Make sure you that there is at least 1/3 left of the battery capacity, loss off power during below will destroy the unit!

You should press "5" first, keep it pressed and then press the "2" and keep it pressed.

Thereafter while pressing "2" and "5", you attach the USB cable.

When information box appears in the Service Client window, release the keys.



Select "Yes" and the Pre-configuration will proceed as normal.

If this doesn't help proceed to pre-config (2) below:

Pre-config (2) fix for "Inaccessible GDFS"

Require access to Activate in Emma III.

Instructions:

1) Connect the phone to EMMAIII with a USB cable while pressing the "C" button.

1a) If EMMAIII is showing a USB icon, apply normal trouble shooting.

1b) If you can't see a USB icon, continue with 2 below.

2) Remove and re-insert the battery and make sure Emma III is working online. Press "5" first, keep it pressed and then press the "2" and keep it pressed. There after and while pressing "2" and "5" attach the USB cable to the phone.

2a) If there is no USB icon in Emma III you shall apply normal trouble shooting.

2b) If you now can see a USB icon in Emma III followed by below information box:

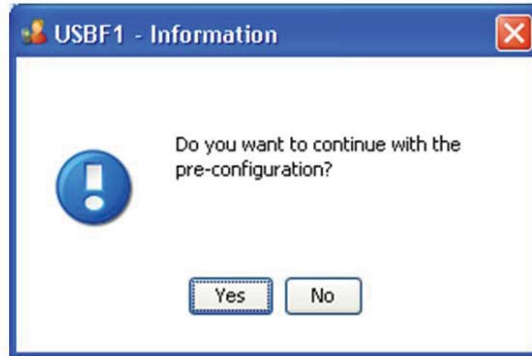

Press No (this box is needed to be able to support both variants of pre-configuration)

If you now get the box with "Pre-configuration 2" script below, you should run this script.

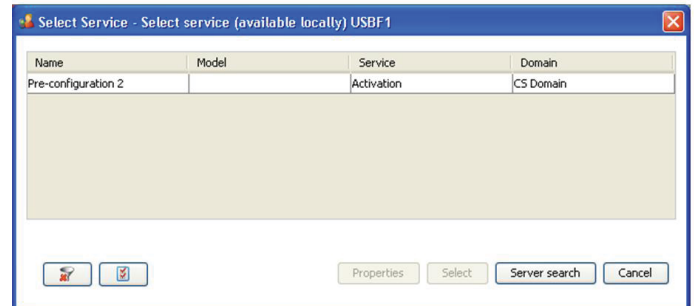

When this script is finished, you must download the DPY/Z script with the "c" key and USB cable as usual.
If you have units with exactly this symptom and the Pre-configuration and Pre-configuration 2 have not solved the problem, please submit a BO errand and send in samples.

If you do not have access to activate, you will not see the "pre-configuration 2" script, please send the unit to a scrap recovery center or center with access to activate appointed by your local Sony Ericsson contact.

Note: The SEPI support in EMMA III (only) for these products has been removed in order for Pre-configuration 2 to work.

Information provided by:

Customer Services
Sony Ericsson Mobile Communications AB

Helpdesk

Phone: +46 46 19 49 80
E-mail: CS-Applications.Support@sonyericsson.com

Reference number: 15600-63909
Created: 2007-09-06
Author: Patrik Cesar (patrik.cesar@ecs.ericsson.se)

SI-Joystick Switch Replacement

Instruction:

It is very important to avoid that you get flux remains inside the joysticks contact surfaces in order to avoid re-repair!

When you replace a joystick switch you MUST:

1. Avoid using extra flux!
2. Do not clean the area around the joystick with alcohol or similar. It will dissolve flux on the PCB and bring it into the joystick switch if you are not very careful.

Watch the joystick replacement movie on CSPN:

CSPN/ Repair instructions/ Standard/[product] (ex. K800) / JOYSTICK SWITCH MOVIE GENERAL

JOYSTICK SWITCH MOVIE GENERAL

[JOYSTICK_SWITCH_MOVIE_GENERAL.PKZIPV2R04.zip](#)

Reference number: 15365-61602

Created: 2007-05-09

Author: Patrik Cesar (patrik.cesar@ecs.ericsson.se)

SI-K800/K790 SI-Support Pad for Camera Switch

Background:

We have seen some cases reported that the shutter function doesn't work, i.e. the camera is not activated / deactivated by it.

This can be caused by that the camera switch tilts up a little due to incorrect assembly. From Production week 06W26 a support pad was added in the antenna cover to prevent these problems at assembly.

Instruction:

If you order new antenna covers you will get this support pad attached to the antenna cover.



Support pad on the antenna cover.

If you have old antenna covers without these or get in units produced earlier than W626 we will make this support pad available as a spare part so you can add it to them to prevent any problems during assembly. It is expected within a few weeks. There will be an update when they are available.

Reference number: 14861-57674

Created: 2006-10-19

Author: Patrik Cesar (patrik.cesar@ecs.ericsson.se)

SI-K800/K790 Problem with front spare part

Background:
We have seen some cases of cosmetic gap problems reported on the spare part front. The cause to the problems is that some of the hooks in the K800/K790 spare part front have unhooked during transport. This has not been seen in production since the front is not transported or stored there.

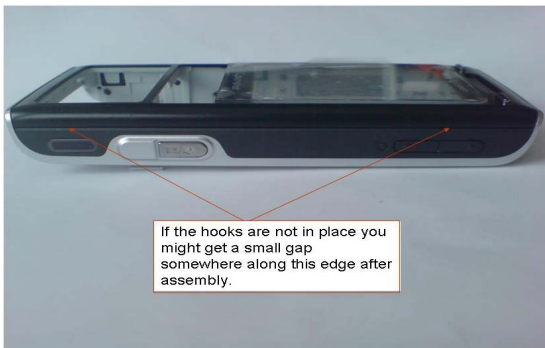

In order to avoid having to reassemble the phone if there is a problem and securing the quality, please follow the instructions below.

Instruction:
You should always first ensure that the 6 hooks (3 on each side) are in place before assembly by gently pushing them with a blunt plastic tool.

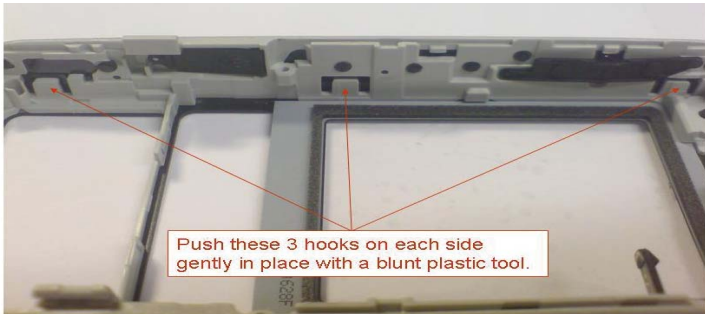

After the hooks are in place they will stay there locked in place by the other components in the phone.

Reference number: 15129-59878
Created: 2007-02-26
Author: Patrik Cesar (patrik.cesar@ecs.ericsson.se)

SI-K800/K790 Problem with On/Off button

Background:
In our scrap analyze we have seen a few cases where the on / off button is stuck in the down position. The unit then starts directly and the other keys do not work. In W642 there was done an improvement in production regarding the on/off key.

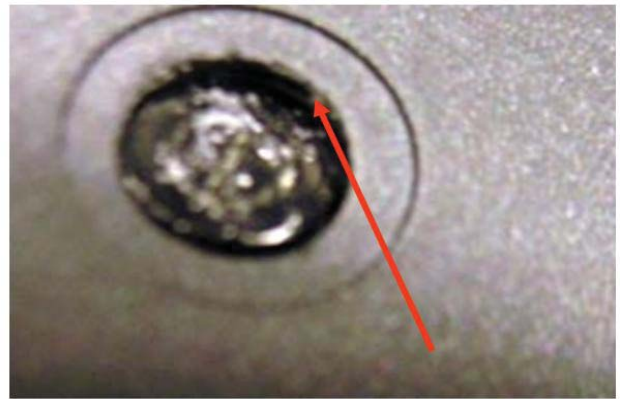

Recommendation:
If the K790 or K800 is produced before 06W42 and you are opening the unit due to other mechanical and electrical problems, the on / off button shall be replaced at the same time.

Reference number: 15168-60144
Created: 2007-03-13
Author: Patrik Cesar (patrik.cesar@ecs.ericsson.se)

SI - White screen patch in Emma3

Affected products:

K800, K790, K610, K618, V630, W850, K610im, Z610, W710, Z710, W830

Description:

Emma3 has been updated and now has an implemented solution for white screen problem seen on many different phones, e.g. W850 & Z610. Please note that it's not a physical script which has been released, but a new set of Emma3 loaders. This affects the initial identification phase when connecting a unit to Emma3.

Please note that this solution is not applicable for all white screen problems. I solves the recent white screen problems caused by ST memory failures.

To trigger White screen problem one can change the theme 15 times straight. This triggers the problem on a non-patched unit with bad ST memory.

IMPORTANT!

Emma3 must be restarted in order for the new loaders to be downloaded locally to PC. "Software Update Content Refresh" OR "Customize" MUST be downloaded in affected phone in order to successfully and completely recover a unit from white screen problem. Scripts used, and thus locally cached MUST be downloaded again from the Server using "Server Search". Make sure to use a fully charged battery! Loader will be downloaded in the initial detection phase and it is CRUCIAL that this step is not interrupted. If detection phase is interrupted the phone can become totally unrecoverable. It is NOT sufficient to run Software Update or using the Update Service, Update Service Pro or FOTA services.

Units that contain "infected" ST memory but still not got white screen symptom need to be updated (using SUCR or Customize) in order to secure them from not getting white screen problem in the future. If there are many units on stock or in warehouse that need to be screened for ST memory, there is a "White Screen Memory Test" script in Emma3 (Service Information reference number: 1497958607) Memory test will only distinguish between Intel and ST. It can not tell if phone with ST memory has been patched and hence is a good unit.

Reference number: 14980-58609

Created: 2006-12-05

Author: [Jens Lindström \(jens.lindstrom@sonyericsson.com\)](mailto:jens.lindstrom@sonyericsson.com)

SI - Sporadic behaviour for Activate

Below only applies if you have access to the Activation service in EMMA 3

Applicable only for: K800, K790, W850, W830, K610, K610im, K618, V630, Z610, W710, and Z710.

Description

The latest update for above products has caused a very minor sporadic behaviour on certain occasions (not constantly and not on all phones) for Activate.

The behaviour is as follows: During the running of "Activation" script, the phone may start up in "USB transfer mode".

If the phone has started up in "USB transfer mode" during the time the "Activation" script is running, the phone will automatically shut itself down after physical removal from USB cable.

Please note, the behaviour is not harmful and does not cause issues of any kind other than sporadic behaviour changes.

By entering "USB transfer mode" the unit will automatically shutdown when the cable is removed, as apposed to manual shutdown normally. Either way, the unit still needs to be restarted after the activation process to enable the activation.

We are investigating what is creating this behaviour so we can remove it, in order to have a consistent behaviour.

Reference number: 15010-58848

Created: 2006-12-22

Author: [Patrik Cesar \(patrik.cesar@ecs.ericsson.se\)](mailto:patrik.cesar@ecs.ericsson.se)

SI-K800/K610 Pre-configuration change

Applicable for: K800/K790/K610/V630/K618

Information:

The Pre-configuration process is updated on EMMA III. The Pre-configuration can fix and prevent "Can not power on" problems on units made before approx. 06W42.

Please note that this update will not start until the EMMA III client is restarted!

Instruction:

Log on to EMMA III as usual. You should press "5" first, keep it pressed and then press the "2" and keep it pressed. Thereafter while pressing "2" and "5", you attach the USB cable. When icon appears in the Service Client window, release the keys. Previously, you've had an automatically performed Pre-configuration, but due to needed structural changes, there will be a question to respond to.



Select "Yes" and the Pre-configuration will proceed as normal.



When selecting "No", the operation will be cancelled.

There is no need at this stage to update the software if you have the latest software version for the DPY.

IMPORTANT!

The pre-configuration process is successful even if EMMA III states that the script failed.

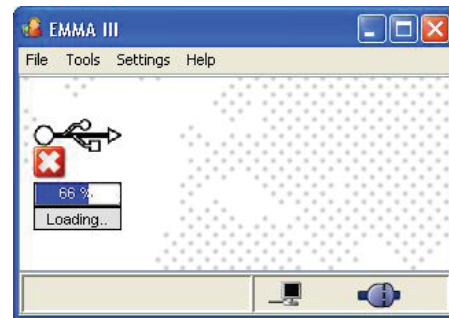

The pre-configuration process is successful anyway.

MU Information:

This change is done to support a recovery script to be used in the scrap recovery centers. (BMC will not need it since region China have not been affected by the simlock bug)

Reference number: 15195-60423

Created: 2007-03-21

Author: Patrik Cesar (patrik.cesar@ecs.ericsson.se)

SI - Vincenne replacement for SL4 and SL5

This document is applicable for

SL4 and SL5 centers with access to:
 ROP1013057/1 ASIC Vincenne
 ROP1013057/2 ASIC Vincenne Leadfree
 ROP1013057/3 ASIC Vincenne Leadfree
 ROP1013066/2 PROD. ADAPT. CIRCUIT/ASIC Vincenne2 A07
 ROP1013066/5 ASIC, Vincenne2 A07 Cu-Plug Thin Ni (Pb-
 ROP1013066/6R1A ASIC Vincenne2 A07 1.8V Cu-Plu

Description:

Vincenne 2 is now available again as spare part for level 4. After you have replaced Vincenne, you MUST do a Vincenne calibration with the new "Vincenne calibration tool"

After the Vincenne calibration in "Vincenne calibration tool" you MUST do a normal SERP (RF calibration) in order to avoid a high re-repair rate and bad quality perception of the product.

Failing to do the mandatory calibration correctly will result in that the access to Vincenne will be permanently withdrawn for the service center.

System Requirements

At least a Pentium III 500 MHz, with 128 MB of RAM
 Win2000 or Win XP
 One free USB connector
 At least 1024x768 display resolution. (1152x864 is recommended.)
 SEPI interface must be installed.
 SEPI A1 Cable
 Dummy battery
 CST-60 Charger
 CST-75 Charger cable (customized according instruction)
 One dual or two single Channel Power Supplies. (Equipment Setup)

Software is found in CSPN under "Repair Instructions>Standard>VINCENNE CALIBRATION TOOL 20/031 62-2/FEA 209 544/755 ". In the zip-package there are also installation instructions. Instructions on how to use the tool are found under the menu Help in the Vincenne calibration tool (also attached below). Important: Make sure you connect the CST-75 Charger cable according instructions, i.e. between the Phone and the SEPI A1 cable and not in the SEPI A1 cable!!

Reference number: 15382-61799

Created: 2007-05-15

Author: [Patrik Cesar \(patrik.cesar@ecs.ericsson.se\)](mailto:patrik.cesar@ecs.ericsson.se)

SI-EMMA 3 IMPORTANT Start-up operation

K800, K790, K610, V630, K618

In order to get the important pre-configuration on units made before 06W42 you should press "5" first, keep it pressed and then press the "2" and keep it pressed. Thereafter while pressing "2" and "5", you attach the USB cable. Keep the buttons pressed until there is a message appearing in Emma III (This will fix some of the "dead" or "white screen" units)

Reference number: 15177-60248

Created: 2007-03-19

Author: [Patrik Cesar \(patrik.cesar@ecs.ericsson.se\)](mailto:patrik.cesar@ecs.ericsson.se)

SI-New software R8BA024

Applicable for K810, K818

Note: No more general releases planned for K800, K790

(i.e. no default update of all those DPY / SI that doesn't require a Operator Acceptance).

Information

New and improved software R8BA024 for K810, K818 is about to be released on EMMA III.

Due to the number of models and kits that are affected there will be a transition period until all of the scripts are updated. We will start the release 07w44 and we estimate to have finalised the work during 07w47.

For those DPY / SI with operator acceptance, the release date will depend on the approval from the operator.

Reference number: 15805-65184

Created: 2007-10-31

Author: [Patrik Cesar \(patrik.cesar@ecs.ericsson.se\)](mailto:patrik.cesar@ecs.ericsson.se)

Torque Settings K790, K800 and K810

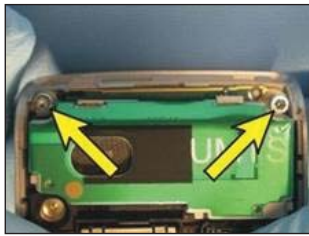

Install four M1.4 screws where indicated using a torque driver set at **22 N*cm** with an T6 bit.

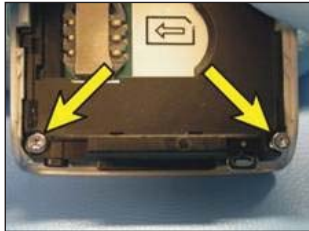

Install two M1.7 screws in the locations indicated using a torque driver set at **10 N*cm** with a JCIS No. 0 bit.

Placing in a Shield Box



The picture shows how to place the K800-unit in a Rohde & Schwartz Shield Box and Coupler

www.s-manuals.com